

JOB NAME _____
 ARCHITECT _____
 ENGINEER _____
 CONTRACTOR _____
 LOCATION _____

SUBMITTAL SHEET
 Form Number DS0402.4 Effective Date 2/16
 Replaces Form DS0402.3

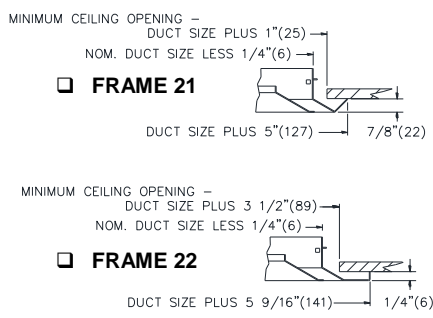

SHPC / 5SHPC SERIES SQUARE / RECTANGULAR LOUVER FACE WITH PATTERN CONTROLLERS

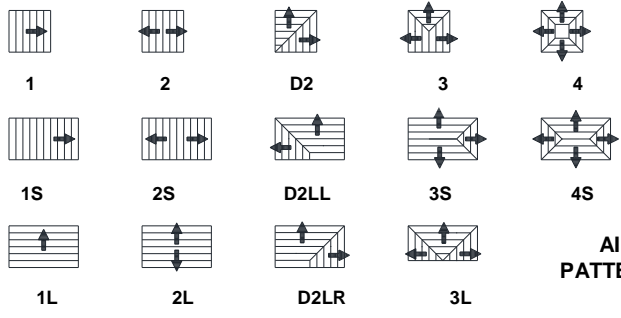

AIR PATTERNS

SHPC / 5SHPC SURFACE MOUNT

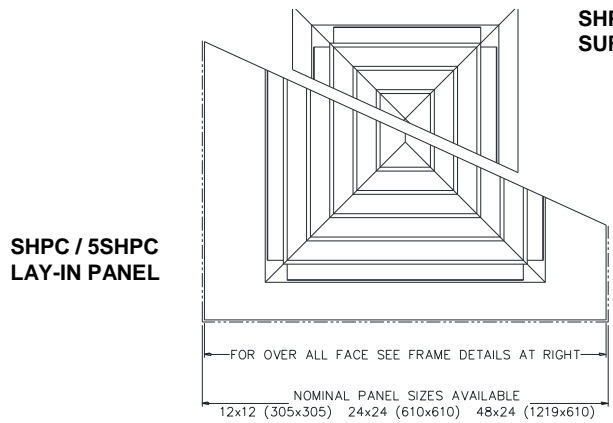

SHPC / 5SHPC LAY-IN PANEL

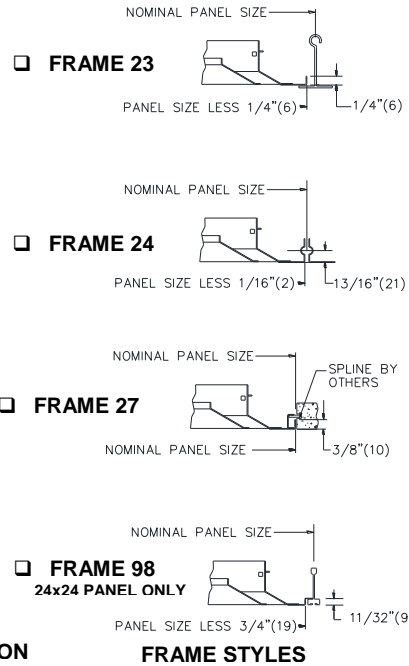

CORNER DUCT STOP DETAIL
 2 PER SIDE TYP

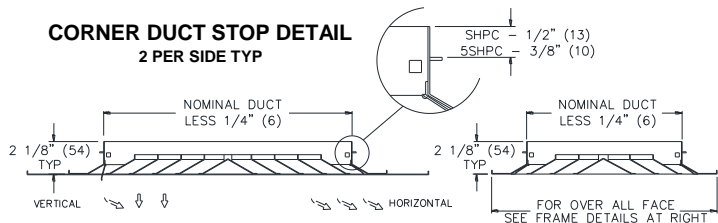

NOTES:

1. SHPC SERIES IS STEEL CONSTRUCTION WITH A SPRING LATCH CORE.
2. 5SHPC SERIES IS ALUMINUM CONSTRUCTION WITH SPRING LATCH CORE.
3. NOMINAL INLET SIZES ARE AVAILABLE AS SQUARE OR RECTANGLE IN 3" (76) INCREMENTS.

ACCESSORIES:

- DAMPERS SHIP SEPARATELY.
- OBDFA FOR SHPC
- 5OBDFA FOR 5SHPC
- SSG - STEEL STRAIGHTENING GRID

FRAME STYLE	PANEL SIZE	MIN INLET DIM1xDIM2	MAX INLET DIM1xDIM2
21, 22	-	6 x 6	21 x 21
23, 24, 27	12 x 12	6 x 6	6 x 6
23, 24, 27, 98	24 x 24	6 x 6	18 x 18
23, 24, 27	48 x 24	12 x 12	18 x 18 *21 x 18

*21 x 18 AVAILABLE AS SHPC ONLY
 DIMENSIONS ARE SHOWN AS INCHES (MM)