

JOB NAME _____
 ARCHITECT _____
 ENGINEER _____
 CONTRACTOR _____
 LOCATION _____

SUBMITTAL SHEET
 Form Number DS0408 Effective Date 1/00
 Replaces Form 3332

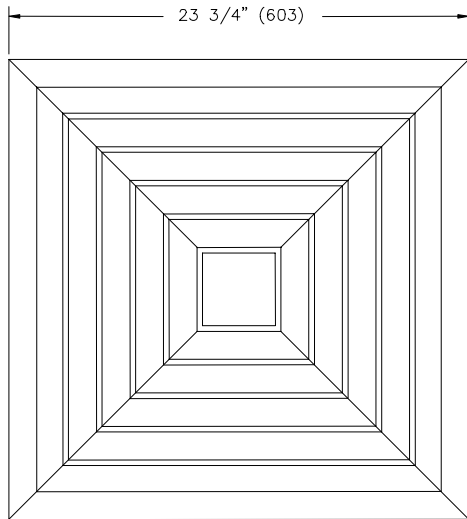

**SHFR SERIES
 FIRE RATED DIFFUSER**



FACE VIEW – FRAME 23

INLET SIZES AVAILABLE	NOMINAL PANEL 24 x 24 (610 x 610)
	6x6 (152x152)
	9x9 (229x229)
	12x12 (305x305)
	15x15 (381x381)
18x18 (457x457)	

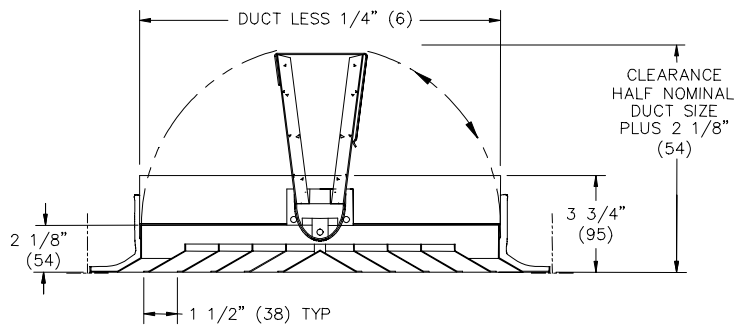

CROSS SECTION

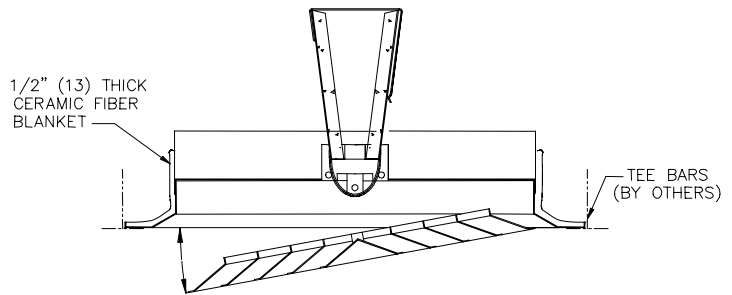

REMOVABLE CORE

**SUPPLY
PATTERN
OPTIONS**



1 WAY



2 WAY



D2



3 WAY



4 WAY



NOTES :

- SERIES **SHFR FRAME 23** OFFERS A, UL CLASSIFIED, FIRE RATED ASSEMBLY THAT INCORPORATES A THREE HOUR FIRE DAMPER WITH A 1/2" (13) THICK CERAMIC FIBER BLANKET.
- ALL STEEL CONSTRUCTION – 24"x24" (610X610) PANEL ONLY
- SQUARE NECKS AVAILABLE IN 3" INCREMENTS ONLY
- SPRING SET REMOVABLE CORE
- FINISH IS 44 BRITISH WHITE

**DIMENSIONS ARE GIVEN AS
 INCHES (MM)**