

JOB NAME _____
 ARCHITECT _____
 ENGINEER _____
 CONTRACTOR _____
 LOCATION _____

SUBMITTAL SHEET
 Form Number DS0405.3 Effective Date 6/04
 Replaces Form DS0405.2

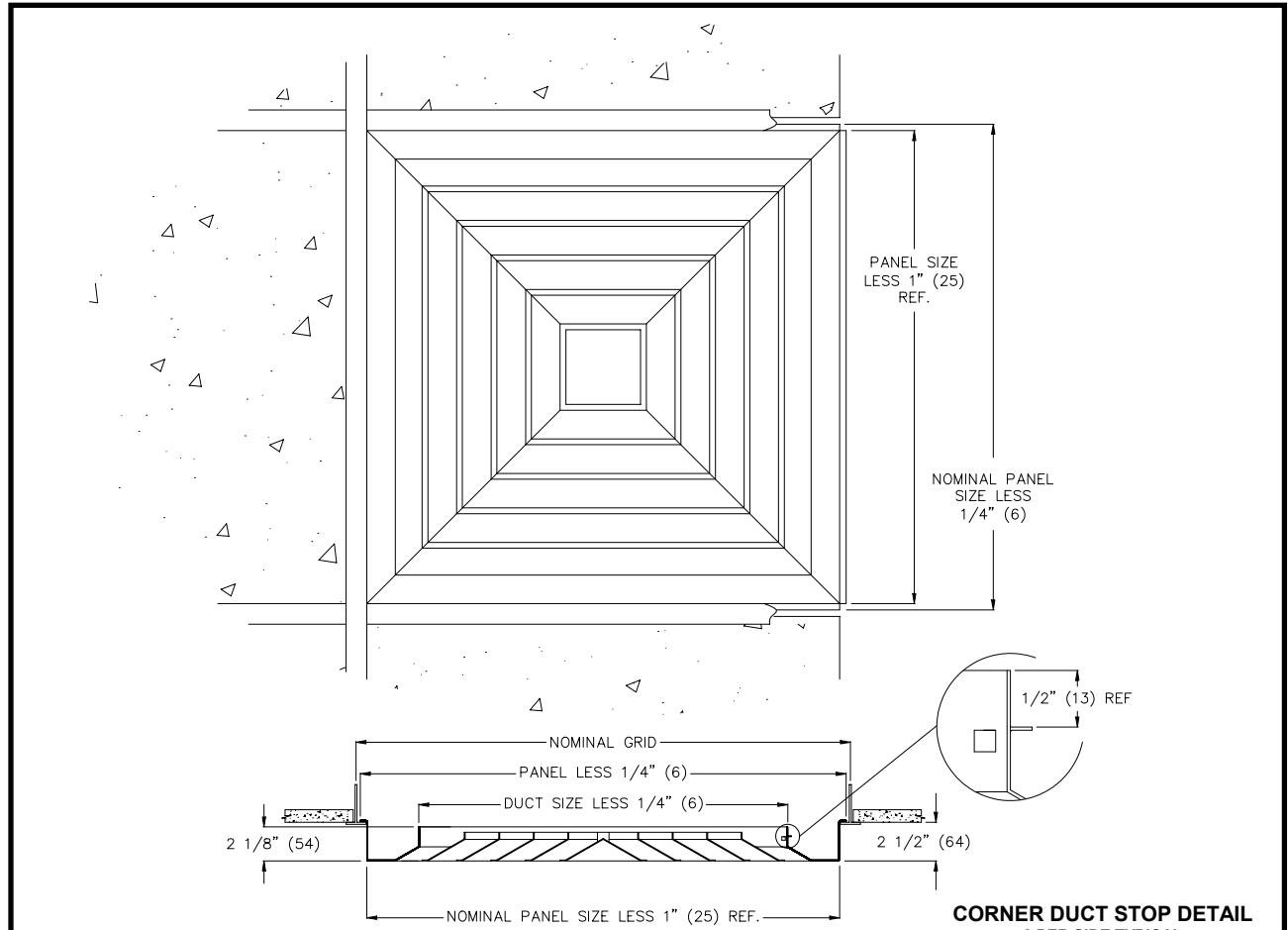

SH SERIES FRAME 2T
SQUARE LOUVER WITH 2 1/2" DROP FACE



AIR PATTERNS

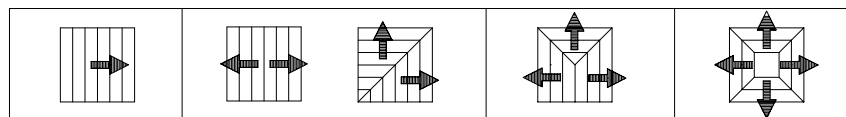

1-WAY

2-WAY

3-WAY

4-WAY

NOTES:

- SH FRAME 2T UNITS ARE STEEL CONSTRUCTION WITH A SPRING LATCH CORE.
- STANDARD FINISH IS 44 WHITE.

ACCESSORIES:

- OBDFA FACE OPERATED OPPOSED BLADE DAMPER SHIPS SEPARATELY
- SSG – SQUARE STEEL STRAIGHTENING GRID

NOMINAL DUCT SIZE	PANEL SIZE
18x18 (457x457)	24x24 (610x610)
42x42 (1067x1067)	48x48 (1219x1219)

DIMENSIONS ARE SHOWN AS INCHES (MM)