

JOB NAME \_\_\_\_\_  
 ARCHITECT \_\_\_\_\_  
 ENGINEER \_\_\_\_\_  
 CONTRACTOR \_\_\_\_\_  
 LOCATION \_\_\_\_\_

**SUBMITTAL SHEET**  
 Form Number DS0404.3 Effective Date 6/04  
 Replaces Form DS0404.2

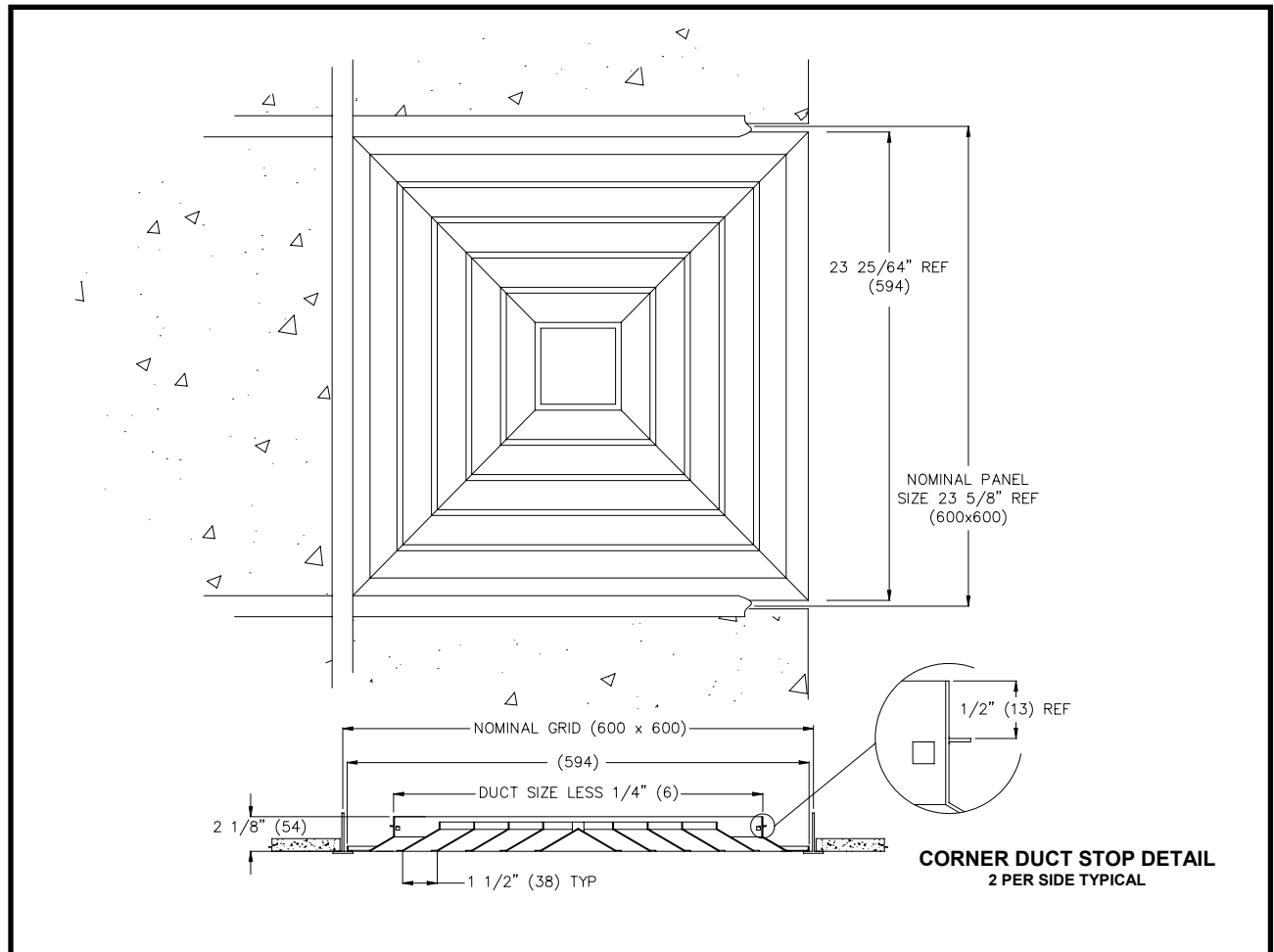

**MSH SERIES**  
**SQUARE LOUVER FOR METRIC GRID SYSTEMS**



**AIR PATTERNS**

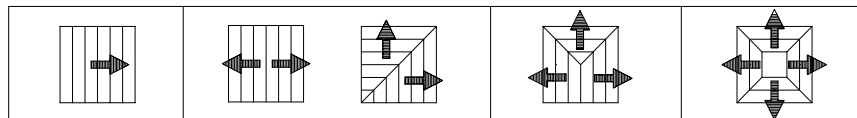

**1-WAY**

**2-WAY**

**3-WAY**

**4-WAY**

**NOTES:**

1. MSH UNITS ARE STEEL CONSTRUCTION WITH A SPRING LATCH CORE.
2. INLET DUCT SIZES ARE BASED ON 3" INCREMENTS.
3. STANDARD FINISH IS 44 WHITE.

**ACCESSORIES:**

- OBDFA** FACE OPERATED OPPOSED BLADE DAMPER SHIPS SEPARATELY
- SSG** – SQUARE STEEL STRAIGHTENING GRID

NOMINAL DUCT SIZE	METRIC PANEL SIZE
6x6 (152x152)	23 5/8 (600x600)
9x9 (229x229)	
12x12 (305x305)	
15x15 (381x381)	

**DIMENSIONS ARE SHOWN AS INCHES (MM)**