

JOB NAME _____
 ARCHITECT _____
 ENGINEER _____
 CONTRACTOR _____
 LOCATION _____

SUBMITTAL SHEET
 Form Number GC0303 Effective Date 3/03
 New Issue



Prism

ARCHITECTURAL CEILING DIFFUSER 24X24, SQUARE NECK

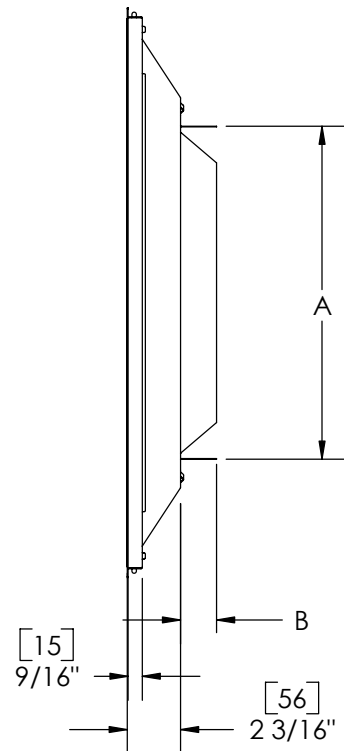
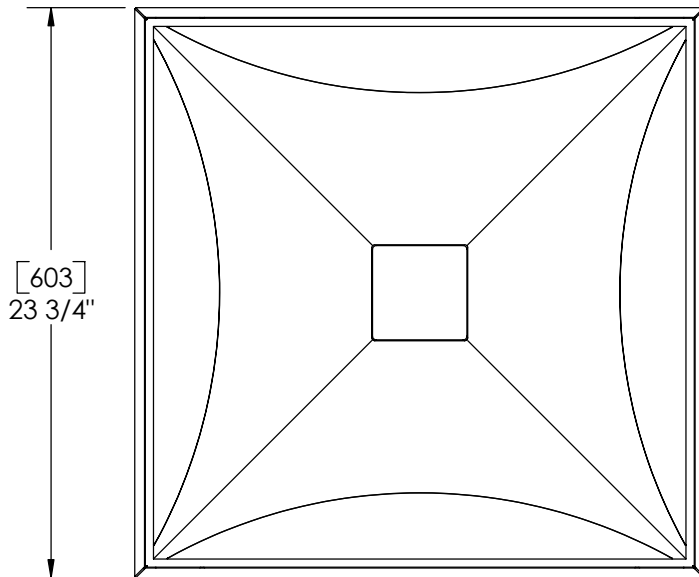

NECK SIZE	A	B
6	5 7/8" [149]	1 1/2" [38]
8	7 7/8" [200]	1 1/2" [38]
10	9 7/8" [251]	1 1/2" [38]
12	11 7/8" [302]	1 1/2" [38]
14	13 7/8" [352]	1 1/2" [38]

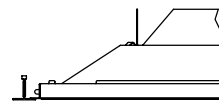

FRAME 23

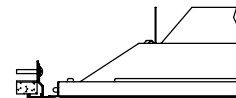

FRAME 22

NOTES:

1. ALL STEEL CONSTRUCTION
2. HINGED REMOVABLE FACE
3. SELF-ADHESIVE COLOR APPLIQUE
4. STANDARD FINISH: #44 WHITE
5. FRAME 22 ALWAYS INCLUDES AN ALUMINUM MTG. FRAME
6. ALL DIMENSIONS IN INCHES & [mm]