

JOB NAME _____
 ARCHITECT _____
 ENGINEER _____
 CONTRACTOR _____
 LOCATION _____

SUBMITTAL SHEET
 Form Number TS0013.4 Effective Date 12/05
 Replaces Form TS0013.3

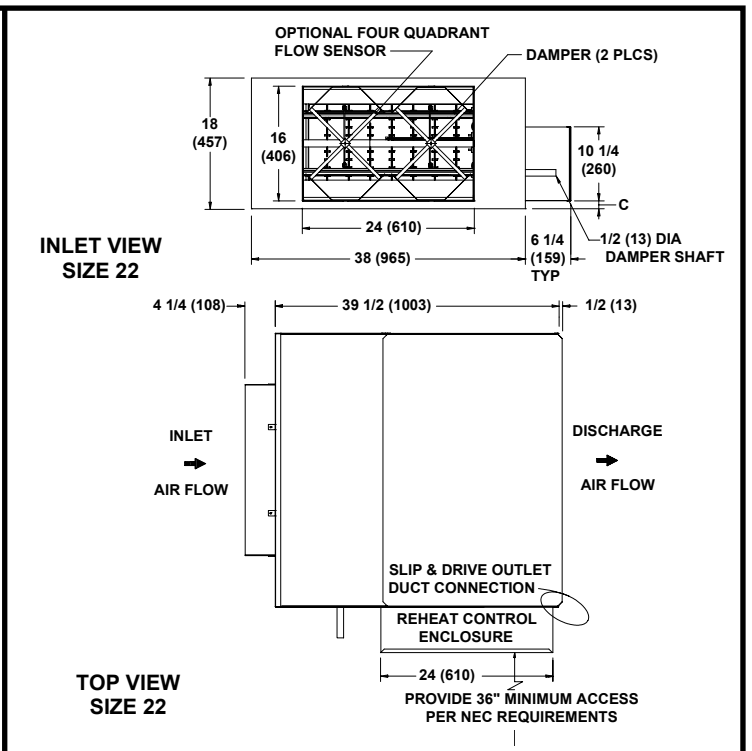

LMHS
ELECTRIC HEAT UNIT – FIELD SUPPLIED & INSTALLED PNEUMATIC CONTROL

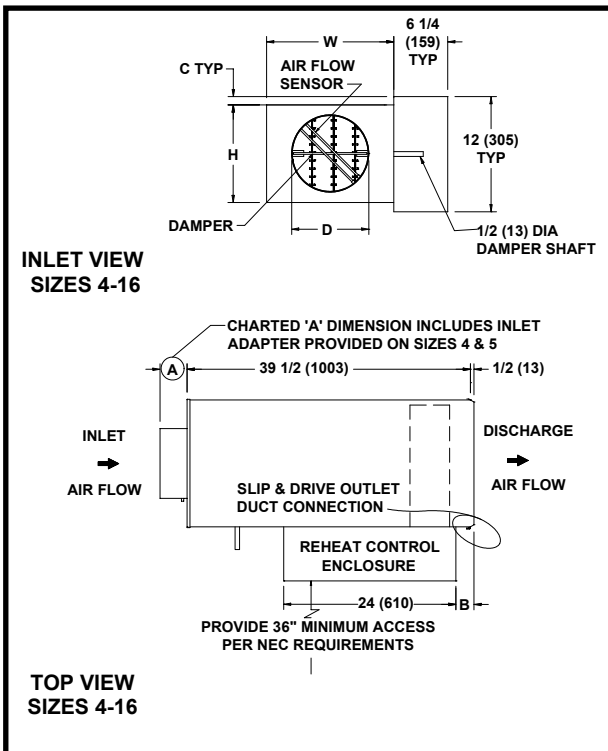

STANDARD FEATURES:

- 22 Ga. Zinc coated steel construction.
- 1/2" dia shaft extending from the unit casing .
- 1/2" thick dual density fiberglass insulation meeting **NFPA 90A** and **UL 181** safety requirements.
- Linear averaging sensor.
- Field installation of controls
- **ETL** listed electric heater
- PE switches with step controllers when control systems up to 15 amps are specified. At 15 amps or more magnetic contactors are standard or when remote disconnect is specified.
- Control enclosure houses all electric heat control components.
- Automatic reset thermal cutout
- Manual reset thermal cutout
- Positive pressure air flow switch

OPTIONAL FEATURES:

- 20 Ga. Zinc coated steel construction
- Liners:
 - Double-Wall Cellular
 - Sterilwall
 - 1" dual density fiberglass insulation
- Right hand control & electric heat.
- Left hand control & electric heat.
- Four quadrant averaging cross flow sensor.
- Hanger Brackets
- Heater voltages:
 - 120v/1Ø
 - 208v/1Ø
 - 240v/1Ø
 - 277v/1Ø
 - 208v/3Ø/3-wire
 - 480v/3Ø/4-wire
- Direct acting thermostat
- Mercury contactors
- Heater disconnect switch
- Fuse block w/ fuses for primary overload protection
- None
- Steriliner
- Perf double wall
- Reverse acting thermostat
- Dust tight construction
- Heater fused disconnect switch

NOTE :

RIGHT HAND CONFIGURATION SHOWN ABOVE. LEFT HAND IS AVAILABLE

DIMENSIONS ARE GIVEN AS INCHES (MM)

INLET SIZE	NOM MAX CFM (L/s)	W	H	A	B	C	D
4	230 (109)	12 (305)	8 (203)	5 3/8 (136)	5 1/2 (140)	2 (51)	3 7/8 (98)
5	360 (170)	12 (305)	8 (203)	5 3/8 (136)	5 1/2 (140)	2 (51)	4 7/8 (124)
6	520 (245)	12 (305)	8 (203)	3 3/8 (86)	5 1/2 (140)	2 (51)	5 7/8 (149)
7	710 (335)	12 (305)	10 (254)	3 3/8 (86)	5 1/2 (140)	1 (25)	6 7/8 (175)
8	925 (437)	12 (305)	10 (254)	3 3/8 (86)	5 1/2 (140)	1 (25)	7 7/8 (200)
9	1200 (566)	14 (356)	12 1/2 (318)	3 3/8 (86)	3 1/2 (89)	-	8 7/8 (225)
10	1450 (685)	14 (356)	12 1/2 (318)	3 3/8 (86)	3 1/2 (89)	-	9 7/8 (251)
12	2100 (991)	16 (406)	15 (381)	3 3/8 (86)	3 1/2 (89)	-	11 7/8 (302)
14	2900 (1369)	20 (508)	17 1/2 (445)	3 3/8 (86)	1 1/2 (38)	-	13 7/8 (352)
16	3700 (1746)	24 (610)	18 (457)	3 3/8 (86)	1 1/2 (38)	-	15 7/8 (403)
22	7100 (3351)	38 (965)	18 (457)	SEE ABOVE	-	1 1/8 (29)	SEE ABOVE