

INTRODUCTION

The 14SCA series are square face, 3-cone, round neck ceiling diffusers with adjustable airflow pattern controllers between the cones that change the discharge pattern from horizontal to vertical. They are available in a variety of frame styles to help meet the architectural requirements of today's ceilings. The spacing of the inner cones in relation to the backpan result in a design possessing anti-smudge characteristics, preventing the buildup of particles on the ceiling, which is achieved by minimizing the low pressure region inherent to most 4-way directional blow diffusers. The 14SCA is typically used for high ceilings and spot heating or cooling applications in which airflow needs to be directed vertically in order to satisfy a specific load. It can also be applied as a seasonal air outlet device; adjusting for horizontal throw for cooling in warmer months and vertical throw for heating in colder months.

MODELS

14SCA - Steel 3-Cone Louvered Diffuser

514SCA - Aluminum 3-Cone Louvered Diffuser

PANEL SIZES

- 12"x12", 20"x20", and 24"x24"
- 300x300mm and 600x600mm

FEATURES

- Three cones for optimum airflow control
- Adjustable airflow pattern controllers for vertical throw
- Great choice for variable air volume spaces
- Cones feature a one-piece stamped construction without mitered joints
- Round neck for easy connection to round duct
- Anti-smudge design prevents smeared ceilings

ACCESSORIES

- Optional round damper: radial, opposed blade, or butterfly
- Optional R6 insulated backpan
- Optional straightening grid
- Optional surface mounting frame
- Optional 30"x30" lay-in adapter frame
- Optional earthquake tabs

FINISHES

- Standard finish is #WHT White
- Optional finishes available

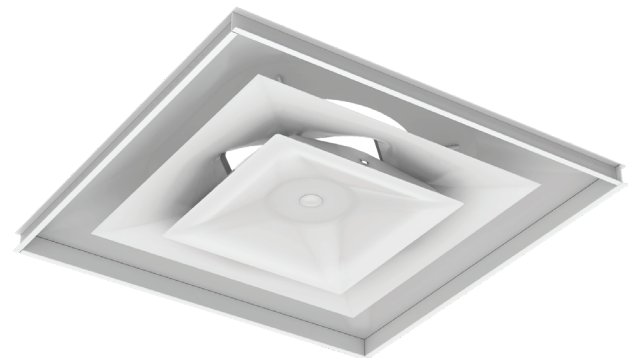
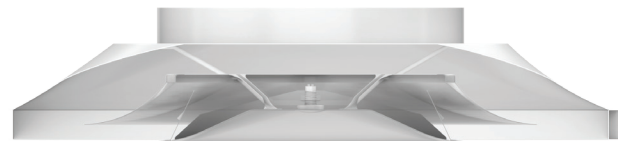

14SCA/514SCA SERIES

Diffuser | Louvered Face, Adjustable



DIMENSIONAL DATA

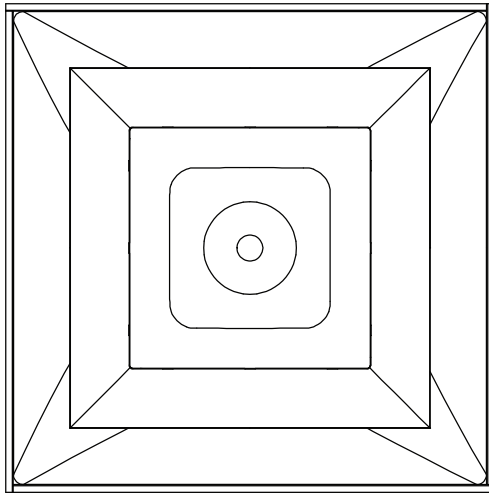

FACE VIEW

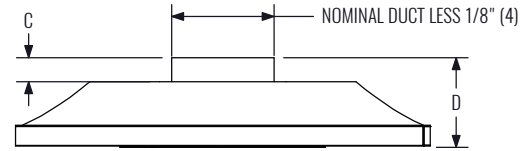

SIDE VIEW

PANEL SIZE	FRAME STYLE	NOMINAL DUCT	C	D
12"x12"	SFM	4", 5"	3 1/8" (80)	5 3/8" (137)
	LTF	6", 7"	1 1/8" (29)	3 3/8" (86)
	SNI	8"	1 1/4" (32)	3 1/2" (89)
	SPL			
20"x20"	SFM	4", 5"	2 3/4" (70)	6 3/8" (162)
	LTF	6", 8", 10"	3/4" (19)	4 3/8" (111)
24"x24"	SFM	6", 8"	1 1/4" (32)	5" (127)
	LTF			
	SPL SNI	10", 12", 14", 15"	1 3/8" (35)	5 1/8" (130)
24"x24" (12"x12" FACE)	L12	4", 5"	3 1/8" (80)	5 3/8" (137)
		6", 7"	1 1/8" (29)	3 3/8" (86)
		8"	1 1/4" (32)	3 1/2" (89)
300x300mm	LTF	4", 5"	3 1/8" (80)	5 3/8" (137)
		6", 7"	1 1/8" (29)	3 3/8" (86)
		8"	1 1/4" (32)	3 1/2" (89)
600x600mm	LTF	6"	1 1/8" (29)	5" (127)
		8"	1 1/4" (32)	5" (127)
		10", 12", 14", 15"	1 3/8" (35)	5 1/8" (130)

NOTES: Dimensions in parentheses are millimeters.
* Adapter frame provided for neck sizes 4" and 5".

DIMENSIONAL DATA

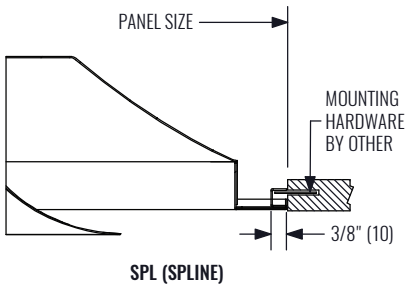
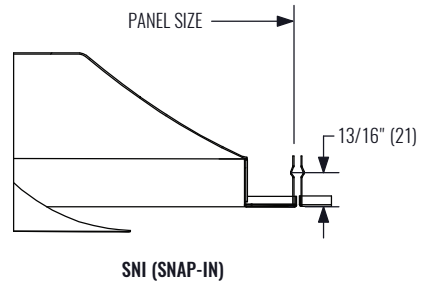
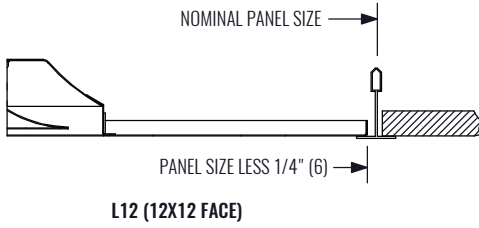
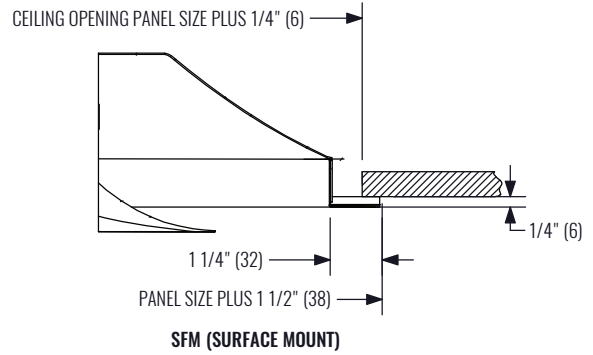
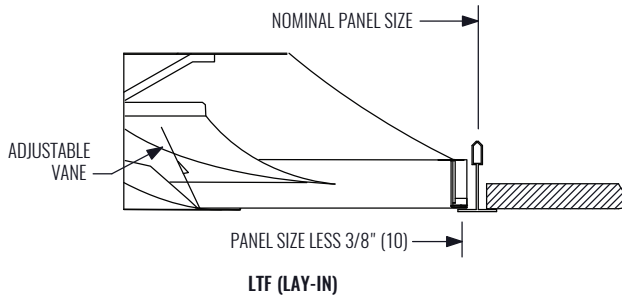

NOTE: Dimensions in parentheses are millimeters.

14SCA/514SCA SERIES



Diffuser | Louvered Face, Adjustable

PERFORMANCE DATA | 12"x12" MODULE, NO DAMPER | HORIZONTAL THROW

NECK SIZE	IP DATA					NC	METRIC DATA				
	NECK VEL	AIR FLOW	HZ Ps	HZ Pt	HZ THROW		NECK VEL	AIR FLOW	HZ Ps	HZ Pt	HZ THROW
	FPM	CFM	"WG	"WG	ft		m/s	L/s	Pa	Pa	m
4" DIA.	400	35	.002	0.012	1 - 1 - 2	-	2.03	17	0.5	3.0	0.3 - 0.3 - 0.6
	500	44	.002	0.018	1 - 2 - 3	-	2.54	21	0.5	4.5	0.3 - 0.6 - 0.9
	600	52	.004	0.026	1 - 2 - 4	-	3.05	25	1.0	6.5	0.3 - 0.6 - 1.2
	700	61	.005	0.036	1 - 2 - 4	-	3.56	29	1.2	9.0	0.3 - 0.6 - 1.2
	800	70	.006	0.046	2 - 2 - 5	13	4.06	33	1.5	11.5	0.6 - 0.6 - 1.5
	1000	87	.010	0.072	2 - 3 - 6	20	5.08	41	2.5	17.9	0.6 - 0.9 - 1.8
	1200	105	.014	0.104	2 - 4 - 7	25	6.10	50	3.5	25.9	0.6 - 1.2 - 2.1
	1400	122	.020	0.142	3 - 4 - 8	30	7.11	58	5.0	35.4	0.9 - 1.2 - 2.4
1600	140	.025	0.185	3 - 5 - 8	34	8.13	66	6.2	46.1	0.9 - 1.5 - 2.4	
5" DIA.	400	55	.008	0.018	1 - 2 - 3	-	2.03	26	2.0	4.5	0.3 - 0.6 - 0.9
	500	68	.012	0.028	1 - 2 - 4	-	2.54	32	3.0	7.0	0.3 - 0.6 - 1.2
	600	82	.019	0.041	2 - 2 - 5	-	3.05	39	4.7	10.2	0.6 - 0.6 - 1.5
	700	95	.025	0.056	2 - 3 - 5	14	3.56	45	6.2	13.9	0.6 - 0.9 - 1.5
	800	109	.033	0.073	2 - 3 - 6	18	4.06	51	8.2	18.2	0.6 - 0.9 - 1.8
	1000	136	.052	0.114	3 - 4 - 8	25	5.08	64	12.9	28.4	0.9 - 1.2 - 2.4
	1200	164	.074	0.164	3 - 5 - 9	31	6.10	77	18.4	40.8	0.9 - 1.5 - 2.7
	1400	191	.101	0.223	4 - 5 - 10	36	7.11	90	25.1	55.5	1.2 - 1.5 - 3.0
1600	218	.131	0.291	4 - 6 - 10	40	8.13	103	32.6	72.5	1.2 - 1.8 - 3.0	
6" DIA.	400	79	.016	0.026	1 - 2 - 4	-	2.03	37	4.0	6.5	0.3 - 0.6 - 1.2
	500	98	.025	0.041	2 - 2 - 5	-	2.54	46	6.2	10.2	0.6 - 0.6 - 1.5
	600	118	.037	0.059	2 - 3 - 6	14	3.05	56	9.2	14.7	0.6 - 0.9 - 1.8
	700	137	.049	0.080	2 - 3 - 7	19	3.56	65	12.2	19.9	0.6 - 0.9 - 2.1
	800	157	.065	0.105	2 - 4 - 7	23	4.06	74	16.2	26.1	0.6 - 1.2 - 2.1
	1000	196	.102	0.164	3 - 5 - 9	30	5.08	93	25.4	40.8	0.9 - 1.5 - 2.7
	1200	235	.146	0.236	4 - 6 - 11	36	6.10	111	36.4	58.8	1.2 - 1.8 - 3.4
	1400	274	.199	0.321	4 - 7 - 12	40	7.11	129	49.6	79.9	1.2 - 2.1 - 3.7
1600	314	.259	0.419	5 - 7 - 13	45	8.13	148	64.5	104.3	1.5 - 2.1 - 4.0	
7" DIA.	400	107	.026	0.036	1 - 2 - 4	-	2.03	50	6.5	9.0	0.3 - 0.6 - 1.2
	500	134	.040	0.056	2 - 3 - 5	12	2.54	63	10.0	13.9	0.6 - 0.9 - 1.5
	600	160	.058	0.080	2 - 3 - 7	18	3.05	76	14.4	19.9	0.6 - 0.9 - 2.1
	700	187	.079	0.110	3 - 4 - 8	23	3.56	88	19.7	27.4	0.9 - 1.2 - 2.4
	800	214	.103	0.143	3 - 4 - 9	27	4.06	101	25.6	35.6	0.9 - 1.2 - 2.7
	1000	267	.161	0.223	4 - 5 - 11	34	5.08	126	40.1	55.5	1.2 - 1.5 - 3.4
	1200	320	.232	0.322	4 - 7 - 13	40	6.10	151	57.8	80.2	1.2 - 2.1 - 4.0
	1400	374	.316	0.438	5 - 8 - 14	44	7.11	177	78.7	109.1	1.5 - 2.4 - 4.3
1600	427	.412	0.572	6 - 9 - 15	49	8.13	202	102.6	142.4	1.8 - 2.7 - 4.6	
8" DIA.	400	140	.037	0.047	2 - 2 - 5	-	2.03	66	9.2	11.7	0.6 - 0.6 - 1.5
	500	175	.057	0.073	2 - 3 - 6	16	2.54	82	14.2	18.2	0.6 - 0.9 - 1.8
	600	209	.083	0.105	2 - 4 - 7	22	3.05	99	20.7	26.1	0.6 - 1.2 - 2.1
	700	244	.112	0.143	3 - 4 - 9	26	3.56	115	27.9	35.6	0.9 - 1.2 - 2.7
	800	279	.147	0.187	3 - 5 - 10	31	4.06	132	36.6	46.6	0.9 - 1.5 - 3.0
	1000	349	.230	0.292	4 - 6 - 12	37	5.08	165	57.3	72.7	1.2 - 1.8 - 3.7
	1200	419	.331	0.421	5 - 7 - 14	43	6.10	198	82.4	104.8	1.5 - 2.1 - 4.3
	1400	489	.451	0.573	6 - 9 - 16	48	7.11	231	112.3	142.7	1.8 - 2.7 - 4.9
1600	558	.588	0.748	7 - 10 - 17	52	8.13	263	146.4	186.3	2.1 - 3.0 - 5.2	

NOTES: Throw values are given for temperature differences shown and terminal velocities of 150, 100, and 50 FPM. NC values are based on octave band 2 - 7 sound power levels minus a room absorption of 10dB, re 10⁻¹² Watts. Dash in space denotes a NC or dB value of less than 10. Data was obtained from tests conducted in accordance with ANSI/ASHRAE Standard 70. See Krueger's selection software for performance data not shown.

PERFORMANCE DATA | 12"x12" MODULE, NO DAMPER | VERTICAL THROW

NECK SIZE	IP DATA					NC	METRIC DATA				
	NECK VEL	AIR FLOW	VT Ps	VT Pt	VT THROW		NECK VEL	AIR FLOW	VT Ps	VT Pt	VT THROW
	FPM	CFM	"WG	"WG	ft		m/s	L/s	Pa	Pa	m
4" DIA.	400	35	0.003	0.013	1-1-2	-	2.03	17	0.7	3.2	0.3-0.3-0.6
	500	44	0.005	0.021	1-1-2	-	2.54	21	1.2	5.2	0.3-0.3-0.6
	600	52	0.008	0.030	1-1-3	-	3.05	25	2.0	7.5	0.3-0.3-0.9
	700	61	0.010	0.041	1-2-3	-	3.56	29	2.5	10.2	0.3-0.6-0.9
	800	70	0.013	0.053	1-2-3	-	4.06	33	3.2	13.2	0.3-0.6-0.9
	1000	87	0.021	0.083	1-2-3	16	5.08	41	5.2	20.7	0.3-0.6-0.9
	1200	105	0.030	0.120	2-3-4	21	6.10	50	7.5	29.9	0.6-0.9-1.2
	1400	122	0.042	0.164	2-3-4	26	7.11	58	10.5	40.8	0.6-0.9-1.2
1600	140	0.054	0.214	2-3-4	30	8.13	66	13.4	53.3	0.6-0.9-1.2	
5" DIA.	400	55	0.012	0.022	1-1-2	-	2.03	26	3.0	5.5	0.3-0.3-0.6
	500	68	0.018	0.034	1-1-3	-	2.54	32	4.5	8.5	0.3-0.3-0.9
	600	82	0.027	0.049	1-2-3	-	3.05	39	6.7	12.2	0.3-0.6-0.9
	700	95	0.035	0.066	1-2-3	12	3.56	45	8.7	16.4	0.3-0.6-0.9
	800	109	0.046	0.086	1-2-4	15	4.06	51	11.5	21.4	0.3-0.6-1.2
	1000	136	0.073	0.135	2-3-4	22	5.08	64	18.2	33.6	0.6-0.9-1.2
	1200	164	0.104	0.194	2-3-5	27	6.10	77	25.9	48.3	0.6-0.9-1.5
	1400	191	0.143	0.265	3-3-5	32	7.11	90	35.6	66.0	0.9-0.9-1.5
1600	218	0.186	0.346	3-4-5	36	8.13	103	46.3	86.2	0.9-1.2-1.5	
6" DIA.	400	79	0.022	0.032	1-1-3	-	2.03	37	5.5	8.0	0.3-0.3-0.9
	500	98	0.033	0.049	1-2-3	-	2.54	46	8.2	12.2	0.3-0.6-0.9
	600	118	0.049	0.071	1-2-4	12	3.05	56	12.2	17.7	0.3-0.6-1.2
	700	137	0.066	0.097	2-2-4	17	3.56	65	16.4	24.2	0.6-0.6-1.2
	800	157	0.086	0.126	2-3-4	21	4.06	74	21.4	31.4	0.6-0.9-1.2
	1000	196	0.136	0.198	2-3-5	27	5.08	93	33.9	49.3	0.6-0.9-1.5
	1200	235	0.194	0.284	3-4-5	32	6.10	111	48.3	70.7	0.9-1.2-1.5
	1400	274	0.265	0.387	3-4-6	37	7.11	129	66.0	96.4	0.9-1.2-1.8
1600	314	0.346	0.506	4-4-6	41	8.13	148	86.2	126.0	1.2-1.2-1.8	
7" DIA.	400	107	0.034	0.044	1-2-3	-	2.03	50	8.5	11.0	0.3-0.6-0.9
	500	134	0.052	0.068	1-2-4	-	2.54	63	12.9	16.9	0.3-0.6-1.2
	600	160	0.076	0.098	2-2-4	16	3.05	76	18.9	24.4	0.6-0.6-1.2
	700	187	0.102	0.133	2-3-5	21	3.56	88	25.4	33.1	0.6-0.9-1.5
	800	214	0.134	0.174	2-3-5	25	4.06	101	33.4	43.3	0.6-0.9-1.5
	1000	267	0.210	0.272	3-4-6	31	5.08	126	52.3	67.7	0.9-1.2-1.8
	1200	320	0.303	0.393	3-4-6	37	6.10	151	75.4	97.9	0.9-1.2-1.8
	1400	374	0.411	0.533	4-5-7	41	7.11	177	102.3	132.7	1.2-1.5-2.1
1600	427	0.536	0.696	4-5-7	45	8.13	202	133.5	173.3	1.2-1.5-2.1	
8" DIA.	400	140	0.047	0.057	1-2-4	-	2.03	66	11.7	14.2	0.3-0.6-1.2
	500	175	0.074	0.090	1-2-4	15	2.54	82	18.4	22.4	0.3-0.6-1.2
	600	209	0.107	0.129	2-3-5	20	3.05	99	26.6	32.1	0.6-0.9-1.5
	700	244	0.144	0.175	2-3-6	25	3.56	115	35.9	43.6	0.6-0.9-1.8
	800	279	0.189	0.229	2-4-6	29	4.06	132	47.1	57.0	0.6-1.2-1.8
	1000	349	0.296	0.358	3-4-7	35	5.08	165	73.7	89.1	0.9-1.2-2.1
	1200	419	0.426	0.516	4-5-7	41	6.10	198	106.1	128.5	1.2-1.5-2.1
	1400	489	0.580	0.702	4-6-8	45	7.11	231	144.4	174.8	1.2-1.8-2.4
1600	558	0.757	0.917	5-6-8	49	8.13	263	188.5	228.3	1.5-1.8-2.4	

NOTES: Throw values are given for temperature differences shown and terminal velocities of 150, 100, and 50 FPM. NC values are based on octave band 2 - 7 sound power levels minus a room absorption of 10dB, re 10⁻¹² Watts. Dash in space denotes a NC or dB value of less than 10. Data was obtained from tests conducted in accordance with ANSI/ASHRAE Standard 70. See Krueger's selection software for performance data not shown.

DIFFUSERS | LOUVERED FACE

14SCA/514SCA SERIES

Diffuser | Louvered Face, Adjustable



PERFORMANCE DATA | 24"x24" MODULE, NO DAMPER | HORIZONTAL THROW

NECK SIZE	IP DATA					NC	METRIC DATA				
	NECK VEL	AIR FLOW	HZ Ps	HZ Pt	HZ THROW		NECK VEL	AIR FLOW	HZ Ps	HZ Pt	HZ THROW
	FPM	CFM	"WG	"WG	ft		m/s	L/s	Pa	Pa	m
6" DIA.	400	79	.008	0.018	2-3-5	-	2.03	37	2.0	4.5	0.6-0.9-1.5
	500	98	.012	0.028	2-3-6	-	2.54	46	3.0	7.0	0.6-0.9-1.8
	600	118	.018	0.040	3-4-7	-	3.05	56	4.5	10.0	0.9-1.2-2.1
	700	137	.024	0.055	3-5-8	14	3.56	65	6.0	13.7	0.9-1.5-2.4
	800	157	.032	0.072	3-6-8	18	4.06	74	8.0	17.9	0.9-1.8-2.4
	1000	196	.050	0.112	4-7-9	25	5.08	93	12.5	27.9	1.2-2.1-2.7
	1200	235	.072	0.162	4-7-10	30	6.10	111	17.9	40.3	1.2-2.1-3.0
	1400	274	.098	0.220	4-7-11	35	7.11	129	24.4	54.8	1.2-2.1-3.4
1600	314	.127	0.287	5-8-12	39	8.13	148	31.6	71.5	1.5-2.4-3.7	
8" DIA.	400	140	.008	0.018	2-3-5	-	2.03	66	2.0	4.5	0.6-0.9-1.5
	500	175	.012	0.028	2-3-6	-	2.54	82	3.0	7.0	0.6-0.9-1.8
	600	209	.022	0.044	3-4-8	12	3.05	99	5.5	11.0	0.9-1.2-2.4
	700	244	.025	0.056	3-5-9	17	3.56	115	6.2	13.9	0.9-1.5-2.7
	800	279	.033	0.073	3-5-10	21	4.06	132	8.2	18.2	0.9-1.5-3.0
	1000	349	.052	0.114	4-6-11	28	5.08	165	12.9	28.4	1.2-1.8-3.4
	1200	419	.074	0.164	5-8-12	33	6.10	198	18.4	40.8	1.5-2.4-3.7
	1400	489	.101	0.223	6-9-13	38	7.11	231	25.1	55.5	1.8-2.7-4.0
1600	558	.131	0.291	7-10-14	42	8.13	263	32.6	72.5	2.1-3.0-4.3	
10" DIA.	400	218	.008	0.018	2-3-6	-	2.03	103	2.0	4.5	0.6-0.9-1.8
	500	273	.013	0.029	3-4-8	-	2.54	129	3.2	7.2	0.9-1.2-2.4
	600	327	.019	0.041	3-5-10	15	3.05	154	4.7	10.2	0.9-1.5-3.0
	700	382	.025	0.056	4-6-11	20	3.56	180	6.2	13.9	1.2-1.8-3.4
	800	436	.033	0.073	4-6-13	24	4.06	206	8.2	18.2	1.2-1.8-4.0
	1000	545	.052	0.114	5-8-14	31	5.08	257	12.9	28.4	1.5-2.4-4.3
	1200	654	.074	0.164	6-10-15	37	6.10	309	18.4	40.8	1.8-3.0-4.6
	1400	763	.102	0.224	8-11-17	41	7.11	360	25.4	55.8	2.4-3.4-5.2
1600	872	.132	0.292	9-13-18	45	8.13	412	32.9	72.7	2.7-4.0-5.5	
12" DIA.	400	314	.008	0.018	3-4-8	-	2.03	148	2.0	4.5	0.9-1.2-2.4
	500	393	.013	0.029	3-5-10	12	2.54	185	3.2	7.2	0.9-1.5-3.0
	600	471	.019	0.041	4-6-12	18	3.05	222	4.7	10.2	1.2-1.8-3.7
	700	550	.025	0.056	5-7-14	23	3.56	260	6.2	13.9	1.5-2.1-4.3
	800	628	.033	0.073	5-8-15	27	4.06	296	8.2	18.2	1.5-2.4-4.6
	1000	785	.052	0.114	6-10-17	34	5.08	370	12.9	28.4	1.8-3.0-5.2
	1200	942	.075	0.165	8-12-18	39	6.10	445	18.7	41.1	2.4-3.7-5.5
	1400	1099	.102	0.224	9-14-20	44	7.11	519	25.4	55.8	2.7-4.3-6.1
1600	1256	.133	0.293	10-15-21	48	8.13	593	33.1	73.0	3.0-4.6-6.4	
14" DIA.	400	428	.019	0.029	5-8-15	-	2.03	202	4.7	7.2	1.5-2.4-4.6
	500	535	.029	0.045	6-10-19	-	2.54	252	7.2	11.2	1.8-3.0-5.8
	600	641	.043	0.065	8-11-21	12	3.05	303	10.7	16.2	2.4-3.4-6.4
	700	748	.058	0.089	9-13-22	18	3.56	353	14.4	22.2	2.7-4.0-6.7
	800	855	.076	0.116	10-15-24	23	4.06	404	18.9	28.9	3.0-4.6-7.3
	1000	1069	.119	0.181	13-19-27	32	5.08	505	29.6	45.1	4.0-5.8-8.2
	1200	1283	.171	0.261	15-21-29	39	6.10	606	42.6	65.0	4.6-6.4-8.8
	1400	1497	.233	0.355	18-22-31	45	7.11	707	58.0	88.4	5.5-6.7-9.4
1600	1710	.304	0.464	19-24-34	50	8.13	807	75.7	115.5	5.8-7.3-10.4	
15" DIA.	400	491	.021	0.031	5-8-16	-	2.03	232	5.2	7.7	1.5-2.4-4.9
	500	614	.032	0.048	7-10-20	-	2.54	290	8.0	12.0	2.1-3.0-6.1
	600	736	.047	0.069	8-12-22	13	3.05	347	11.7	17.2	2.4-3.7-6.7
	700	859	.063	0.094	10-14-24	19	3.56	405	15.7	23.4	3.0-4.3-7.3
	800	982	.083	0.123	11-16-25	24	4.06	463	20.7	30.6	3.4-4.9-7.6
	1000	1227	.130	0.192	14-20-28	32	5.08	579	32.4	47.8	4.3-6.1-8.5
	1200	1472	.187	0.277	16-22-31	39	6.10	695	46.6	69.0	4.9-6.7-9.4
	1400	1718	.255	0.377	19-24-34	45	7.11	811	63.5	93.9	5.8-7.3-10.4
1600	1963	.332	0.492	21-25-36	50	8.13	926	82.7	122.5	6.4-7.6-11.0	

NOTES: Throw values are given for isothermal conditions and terminal velocities of 150, 100, and 50 FPM (0.75, 0.50, and 0.25 m/s). NC values are based on octave band 2 - 7 sound power levels minus a room absorption of 10dB, re 10⁻¹² Watts. Dash in space denotes a NC or dB value of less than 10. Data was obtained from tests conducted in accordance with ANSI/ASHRAE Standard 70, ISO Standard 5219, and ISO Standard 3741. See Krueger's selection software for performance data not shown.

PERFORMANCE DATA | 24"x24" MODULE, NO DAMPER | VERTICAL THROW

NECK SIZE	IP DATA					NC	METRIC DATA				
	NECK VEL	AIR FLOW	VT Ps	VT Pt	VT THROW		NECK VEL	AIR FLOW	VT Ps	VT Pt	VT THROW
	FPM	CFM	"WG	"WG	ft		m/s	L/s	Pa	Pa	m
6" DIA.	400	79	0.009	0.019	0 - 1 - 1	-	2.03	37	2.2	4.7	0.0 - 0.3 - 0.3
	500	98	0.014	0.030	1 - 1 - 2	-	2.54	46	3.5	7.5	0.3 - 0.3 - 0.6
	600	118	0.021	0.043	1 - 1 - 2	-	3.05	56	5.2	10.7	0.3 - 0.3 - 0.6
	700	137	0.027	0.058	1 - 1 - 2	13	3.56	65	6.7	14.4	0.3 - 0.3 - 0.6
	800	157	0.036	0.076	1 - 1 - 3	17	4.06	74	9.0	18.9	0.3 - 0.3 - 0.9
	1000	196	0.056	0.118	1 - 1 - 4	24	5.08	93	13.9	29.4	0.3 - 0.3 - 1.2
	1200	235	0.081	0.171	1 - 2 - 4	29	6.10	111	20.2	42.6	0.3 - 0.6 - 1.2
	1400	274	0.110	0.232	1 - 2 - 4	34	7.11	129	27.4	57.8	0.3 - 0.6 - 1.2
1600	314	0.143	0.303	1 - 2 - 5	38	8.13	148	35.6	75.4	0.3 - 0.6 - 1.5	
8" DIA.	400	140	0.012	0.022	0 - 1 - 1	-	2.03	66	3.0	5.5	0.0 - 0.3 - 0.3
	500	175	0.018	0.034	1 - 1 - 2	-	2.54	82	4.5	8.5	0.3 - 0.3 - 0.6
	600	209	0.027	0.049	1 - 1 - 2	12	3.05	99	6.7	12.2	0.3 - 0.3 - 0.6
	700	244	0.036	0.067	1 - 1 - 2	16	3.56	115	9.0	16.7	0.3 - 0.3 - 0.6
	800	279	0.048	0.088	1 - 1 - 3	20	4.06	132	12.0	21.9	0.3 - 0.3 - 0.9
	1000	349	0.075	0.137	1 - 2 - 4	27	5.08	165	18.7	34.1	0.3 - 0.6 - 1.2
	1200	419	0.107	0.197	1 - 2 - 4	32	6.10	198	26.6	49.1	0.3 - 0.6 - 1.2
	1400	489	0.147	0.269	2 - 2 - 5	37	7.11	231	36.6	67.0	0.6 - 0.6 - 1.5
1600	558	0.191	0.351	2 - 3 - 6	41	8.13	263	47.6	87.4	0.6 - 0.9 - 1.8	
10" DIA.	400	218	0.020	0.030	1 - 1 - 2	-	2.03	103	5.0	7.5	0.3 - 0.3 - 0.6
	500	273	0.031	0.047	1 - 1 - 2	12	2.54	129	7.7	11.7	0.3 - 0.3 - 0.6
	600	327	0.046	0.068	1 - 1 - 3	18	3.05	154	11.5	16.9	0.3 - 0.3 - 0.9
	700	382	0.061	0.092	1 - 2 - 3	22	3.56	180	15.2	22.9	0.3 - 0.6 - 0.9
	800	436	0.080	0.120	1 - 2 - 4	26	4.06	206	19.9	29.9	0.3 - 0.6 - 1.2
	1000	545	0.126	0.188	1 - 2 - 4	33	5.08	257	31.4	46.8	0.3 - 0.6 - 1.2
	1200	654	0.181	0.271	2 - 3 - 5	38	6.10	309	45.1	67.5	0.6 - 0.9 - 1.5
	1400	763	0.247	0.369	2 - 3 - 6	43	7.11	360	61.5	91.9	0.6 - 0.9 - 1.8
1600	872	0.322	0.482	2 - 4 - 7	47	8.13	412	80.2	120.0	0.6 - 1.2 - 2.1	
12" DIA.	400	314	0.030	0.040	1 - 1 - 2	-	2.03	148	7.5	10.0	0.3 - 0.3 - 0.6
	500	393	0.047	0.063	1 - 1 - 3	17	2.54	185	11.7	15.7	0.3 - 0.3 - 0.9
	600	471	0.068	0.090	1 - 2 - 3	23	3.05	222	16.9	22.4	0.3 - 0.6 - 0.9
	700	550	0.092	0.123	1 - 2 - 4	27	3.56	260	22.9	30.6	0.3 - 0.6 - 1.2
	800	628	0.121	0.161	1 - 2 - 4	31	4.06	296	30.1	40.1	0.3 - 0.6 - 1.2
	1000	785	0.189	0.251	2 - 3 - 5	38	5.08	370	47.1	62.5	0.6 - 0.9 - 1.5
	1200	942	0.271	0.361	2 - 3 - 6	43	6.10	445	67.5	89.9	0.6 - 0.9 - 1.8
	1400	1099	0.370	0.492	2 - 4 - 7	48	7.11	519	92.1	122.5	0.6 - 1.2 - 2.1
1600	1256	0.482	0.642	3 - 4 - 9	52	8.13	593	120.0	159.9	0.9 - 1.2 - 2.7	
14" DIA.	400	428	0.034	0.044	2 - 5 - 7	12	2.03	202	8.5	11.0	0.6 - 1.5 - 2.1
	500	535	0.052	0.068	3 - 6 - 8	18	2.54	252	12.9	16.9	0.9 - 1.8 - 2.4
	600	641	0.076	0.098	5 - 6 - 9	23	3.05	303	18.9	24.4	1.5 - 1.8 - 2.7
	700	748	0.103	0.134	6 - 7 - 10	28	3.56	353	25.6	33.4	1.8 - 2.1 - 3.0
	800	855	0.135	0.175	6 - 7 - 10	32	4.06	404	33.6	43.6	1.8 - 2.1 - 3.0
	1000	1069	0.211	0.273	7 - 8 - 12	38	5.08	505	52.5	68.0	2.1 - 2.4 - 3.7
	1200	1283	0.303	0.393	7 - 9 - 13	43	6.10	606	75.4	97.9	2.1 - 2.7 - 4.0
	1400	1497	0.413	0.535	8 - 10 - 14	48	7.11	707	102.8	133.2	2.4 - 3.0 - 4.3
1600	1710	0.539	0.699	8 - 10 - 15	51	8.13	807	134.2	174.1	2.4 - 3.0 - 4.6	
15" DIA.	400	491	0.031	0.041	2 - 5 - 8	-	2.03	232	7.7	10.2	0.6 - 1.5 - 2.4
	500	614	0.048	0.064	4 - 6 - 9	17	2.54	290	12.0	15.9	1.2 - 1.8 - 2.7
	600	736	0.070	0.092	5 - 7 - 10	22	3.05	347	17.4	22.9	1.5 - 2.1 - 3.0
	700	859	0.094	0.125	6 - 7 - 10	27	3.56	405	23.4	31.1	1.8 - 2.1 - 3.0
	800	982	0.124	0.164	6 - 8 - 11	31	4.06	463	30.9	40.8	1.8 - 2.4 - 3.4
	1000	1227	0.194	0.256	7 - 9 - 12	37	5.08	579	48.3	63.7	2.1 - 2.7 - 3.7
	1200	1472	0.279	0.369	8 - 10 - 14	42	6.10	695	69.5	91.9	2.4 - 3.0 - 4.3
	1400	1718	0.380	0.502	8 - 10 - 15	47	7.11	811	94.6	125.0	2.4 - 3.0 - 4.6
1600	1963	0.495	0.655	9 - 11 - 16	50	8.13	926	123.3	163.1	2.7 - 3.4 - 4.9	

NOTES: Throw values are given for isothermal conditions and terminal velocities of 150, 100, and 50 FPM (0.75, 0.50, and 0.25 m/s). NC values are based on octave band 2 - 7 sound power levels minus a room absorption of 10dB, re 10⁻¹² Watts. Dash in space denotes a NC or dB value of less than 10. Data was obtained from tests conducted in accordance with ANSI/ASHRAE Standard 70, ISO Standard 5219, and ISO Standard 3741. See Krueger's selection software for performance data not shown.

14SCA/514SCA SERIES

Diffuser | Louvered Face, Adjustable



DIFFUSERS | LOUVERED FACE

ENGINEERING SPECIFICATION & CONFIGURATION

14SCA, 514SCA

The drop cone, square face diffuser shall be Krueger model 14SCA (steel, adjustable) or 514SCA (aluminum, adjustable). The 14SCA and 514SCA models shall be constructed of three precision die-stamped cones. The back cone shall have an integrally drawn neck for duct connections on 24"x24" and 24"x48" panel sized units. Fabricated collars are only acceptable on 12"x12" panel sized units. The inner cone assembly shall be welded to the back cone and have a hole with removable plug for easy optional damper adjustment. The inner cone assembly shall also include adjustable vanes to change the airflow from fully horizontal to fully vertical. Diffusers shall be constructed of 22 gage steel (14SCA) or 0.040" aluminum (514SCA).

Optional round damper shall be constructed of heavy gage steel. Damper shall be operable from the face of the diffuser.

PERFORMANCE

The manufacturer shall provide published (printed or electronic) performance data for the diffuser. Performance data shall include 2 - 7 octave band sound power levels. The diffuser shall be tested in accordance to the data standards at the time of product introduction or ANSI/ASHRAE Standard 70.

FINISH

The paint finish shall be #44 British White and be an anodic acrylic paint, baked at 315° for 30 minutes. The paint thickness shall be 0.8 - 1.0 mils, gloss at 60° per ASTM D523-89 of 50 - 85%, pencil hardness per ASTM D3363-92A of HB - H, crosshatch adhesion per ASTM D3359-83 of 4B - 5B, impact per ASTM D2794-93 of direct impact >100 in/lb and reverse impact >80 in/lb, salt spray per ASTM B117-9048 of 96 hours, humidity per ASTM D2247-92 of >500 hours and water soak per ASTM D870-92 of 250 hours.

1. SERIES: (XXXXXX)

14SCA - Steel, 3-Cone, Adjustable Diffuser
514SCA - Aluminum, 3-Cone, Adjustable Diffuser*

2. PATTERN: (XXX)

1WY - 1-Way (3 Baffles)
2WY - 2-Way (2 Baffles)
3WY - 3-Way (1 Baffle)
4WY - 4-Way (No Baffles)

3. ROUND NECK: (XX)****

4", 5", 6", 7", 8", 10", 12", 14", or 15"

4. FRAME: (XXX)

LTF - Lay-in T-Bar
L12 - 12"x12" Face, Lay-in T-Bar
SFM - Surface Mount
SNI - Snap-in
SPL - Spline

5. PANEL: (XX)x(XX)

None - No Panel
12x12 - 12"x12"
20x20 - 20"x20"
24x24 - 24"x24"
3Mx3M - Metric 300x300
6Mx6M - Metric 600x600

6. DAMPER: (XXX)

000 - None
RRN - Radial Neck Mounted
RRD - Radial Duct Mounted
RON - Opposed Blade Neck Mounted
ROD - Opposed Blade Duct Mounted
RBN - Butterfly Neck Mounted
COM - Combo (Damper with Equalizing Grid)

7. INSULATION: (XX)

00 - None
R6 - Molded R6 Insulation***

8. EARTHQUAKE TABS: (XX)

00 - None
EQ - Earthquake tabs

9. EQUALIZING GRID: (XX)

00 - None
EG - Equalizing Grid

10. INSTALL FRAME: (XXX)

000 - None
AFR - Rapid Mount Frame (Aluminum)
SFR - Rapid Mount Frame (Steel)
30F - 30"x30" Adapter Frame**

11. FINISH: (XXX)

WHT - White
ALP - Aluminum Paint
CMP - Alkyd Enamel Paint to Match
CMX - Hard Coat Urethane to Match
OWH - Off-White Paint
BLK - Black Paint

See dimensional data for available panel, frame, and neck configurations.

* 514SC only available in frames SFM, LTF, and NTG.

514SC not available in panel size 3Mx3M.

** Adapter frame provided for neck sizes 4" and 5".

*** R6 insulation only available with frame LTF or SFM.

R6 insulation only available with panel size 24"x24".

R6 insulation only available with neck sizes 6", 8", 10", 14", and 15".

**** 7" inlet available in panel size 12x12 only.

SAMPLE CONFIGURATION: 514SCA - 4WY - 06 - LTF - 24x24 - 000 - 00 - 00 - EG - 000 - WHT