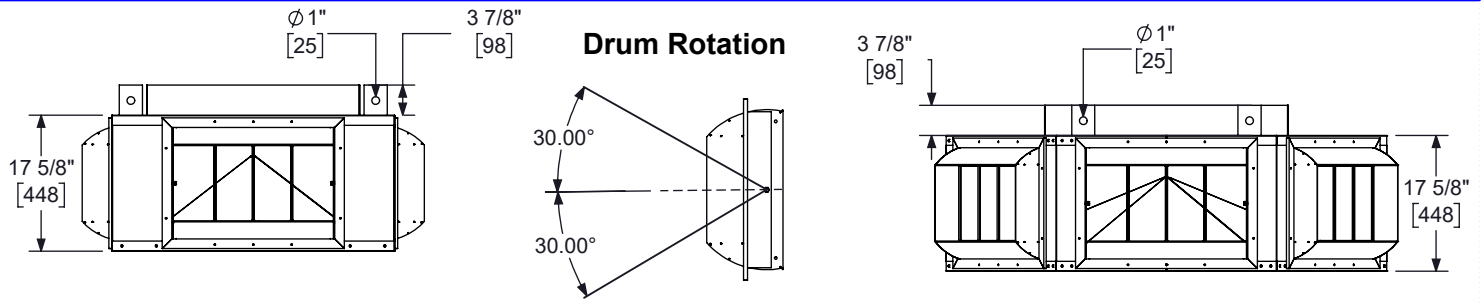
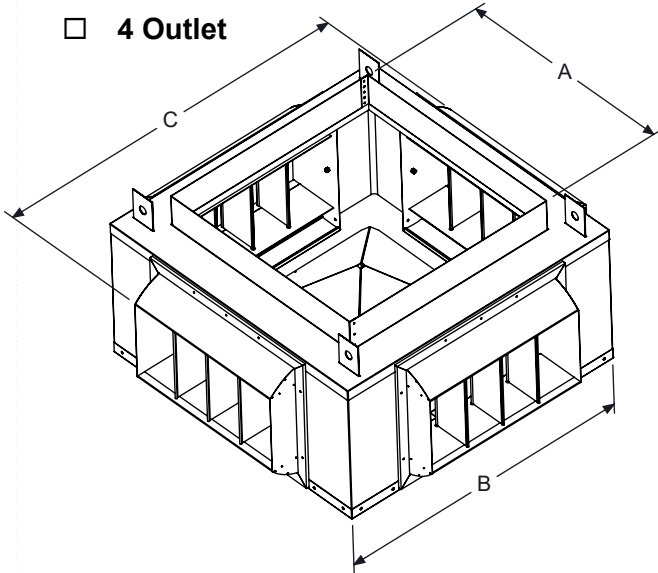
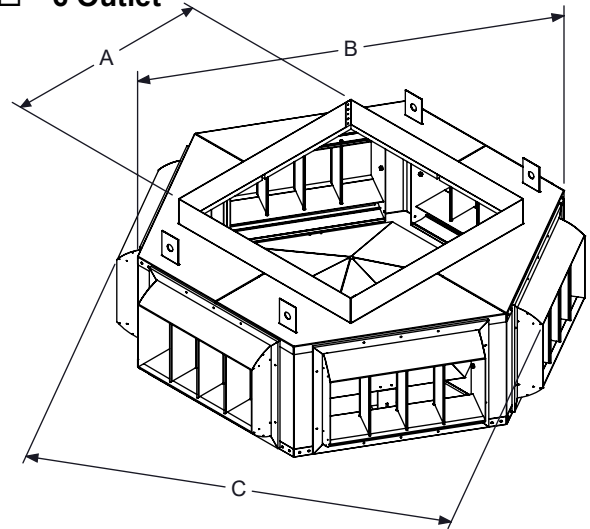

DBM
HIGH CAPACITY DROP BOX MODULE - DRUM LOUVER
SUBMITTAL SHEET

 4 Outlet

 6 Outlet

Outlet Type	Capacity (CFM)	Outlet Size (in)	A	B	C	Weight (lbs)
4 WAY	4,000	21 x 15	23 7/8 [606]	32 7/8 [835]	40 9/16 [1030]	75
4 WAY	5,000	21 x 15	23 7/8 [606]	32 7/8 [835]	40 9/16 [1030]	75
4 WAY	7,500	21 x 15	27 7/8 [708]	36 7/8 [937]	44 9/16 [1132]	80
6 WAY	10,000	21 x 15	31 7/8 [810]	57 1/2 [1461]	58 [1473]	127
6 WAY	12,500	24 x 15	35 7/8 [911]	63 1/2 [1613]	63 [1600]	132
6 WAY	15,000	30 x 15	37 7/8 [962]	75 1/2 [1918]	74 [1880]	179
6 WAY	17,500	30 x 15	39 7/8 [1013]	75 1/2 [1918]	74 [1880]	179
6 WAY	20,000	36 x 15	39 7/8 [1013]	87 1/2 [2134]	84 [2134]	217
6 WAY	22,500	40 x 15	41 7/8 [1064]	95 1/4 [2419]	90 [2286]	263
6 WAY	25,000	40 x 15	43 7/8 [1114]	95 1/4 [2419]	90 [2286]	263

DIMENSIONS ARE GIVEN
IN INCHES [MM]

STANDARD FEATURES:

- INTERNALLY REINFORCED STEEL PLENUM
- INTERIOR BAFFLE TO PROVIDE EFFICIENT AIR DISTRIBUTION
- SUPPLIED WITH KRUEGER MODEL DPL EXTRUDED ALUMINUM DRUM LOUVER OUTLETS FEATURING 30° ADJUSTABLE DRUM ROTATION IN EITHER DIRECTION
- ADJUSTABLE BLADES FOR HORIZONTAL DISTRIBUTION
- INTEGRAL HANGER BRACKETS

OPTIONS:

- INTERNAL 1" FIBERGLASS INSULATION (BLACK)
- INTERNAL 1" FIBER FREE INSULATION (BLACK)

Available Finishes:

- 44 - BRITISH WHITE
- 35 - BLACK
- 49 - OFF WHITE
- 07- ENAMEL PAINT MATCH

 Revision Date: **7/7/2025**

 Form: **GRS13.01**

Replaces:

NEW
Product Information is Subject to Change Without Notice

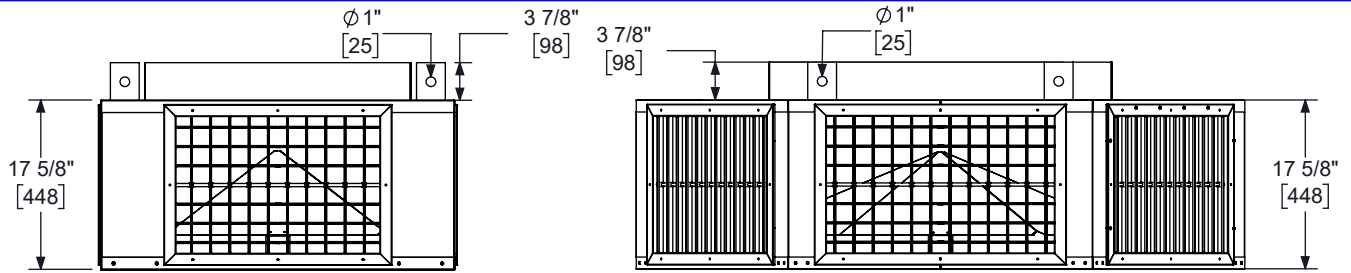
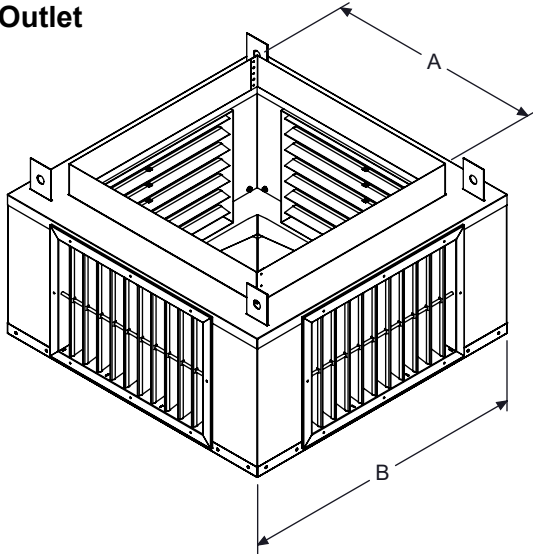
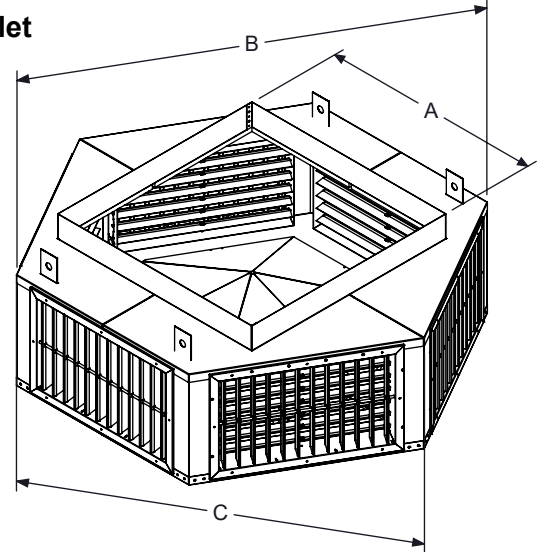
 4 Outlet

 6 Outlet

Outlet Type	Capacity (CFM)	Outlet Size (in)	A	B	C	Weight (lbs)
4 WAY	4,000	22 x 15 1/4	23 7/8 [606]	32 7/8 [835]	-	80
4 WAY	5,000	22 x 15 1/4	23 7/8 [606]	32 7/8 [835]	-	80
4 WAY	7,500	22 x 15 1/4	27 7/8 [708]	36 7/8 [937]	-	85
6 WAY	10,000	21 1/2 x 15 1/4	31 7/8 [810]	57 1/2 [1461]	50 [1270]	134
6 WAY	12,500	24 1/2 x 15 1/4	35 7/8 [911]	63 1/2 [1613]	55 [1397]	136
6 WAY	15,000	30 1/2 x 15 1/4	37 7/8 [962]	75 1/2 [1918]	66 [1676]	188
6 WAY	17,500	30 1/2 x 15 1/4	39 7/8 [1013]	75 1/2 [1918]	66 [1676]	188
6 WAY	20,000	36 1/2 x 15 1/4	39 7/8 [1013]	87 1/2 [2134]	76 [1930]	226
6 WAY	22,500	40 1/2 x 15 1/4	41 7/8 [1064]	95 1/4 [2419]	83 [2108]	273
6 WAY	25,000	40 1/2 x 15 1/4	43 7/8 [1114]	95 1/4 [2419]	83 [2108]	273

**DIMENSIONS ARE GIVEN
IN INCHES [MM]**

OPTIONS:

- INTERNAL 1" FIBERGLASS INSULATION (BLACK)
- INTERNAL 1" FIBER FREE INSULATION (BLACK)

STANDARD FEATURES:

- INTERNALLY REINFORCED STEEL PLENUM
- INTERIOR BAFFLE TO PROVIDE EFFICIENT AIR DISTRIBUTION
- SUPPLIED WITH KRUEGER MODEL 6880-20V INDUSTRIAL SUPPLY GRILLES
- ADJUSTABLE BLADES FOR HORIZONTAL AND VERTICAL DISTRIBUTION
- INTEGRAL HANGER BRACKETS

Available Finishes:

- 44 - BRITISH WHITE
- 35 - BLACK
- 49 - OFF WHITE
- 07- ENAMEL PAINT MATCH