

## MODEL

- KSL - Vertical small footprint blower coil, bottom return

## FEATURES

- Galvanized steel cabinet construction, minimum 18 gauge
- 1" thick foil faced fiberglass insulation
- 1" supply duct collars
- Gasketed, full size removable front access panel
- IAQ galvanized steel drain pan with 1 1/8" ODM copper pipe outlet
- Left and right hand arrangement
- Multiple fan discharge arrangements
- NEMA 1 control enclosure houses electrical options
- External rubber-in-shear or spring type vibration isolators (optional)
- Base rails with rigging slots factory assembled and installed (optional)

## COOLING AND REHEAT COIL OPTIONS

- Chilled water - 4 or 6 rows
- Direct expansion (DX) - 4 or 6 rows
- Hot water - 1 or 2 rows, draw thru or blow thru
- Steam - 1 or 2 rows, blow thru only
- Electric heat

## COILS

- 1/2" O.D. seamless copper tubes
- Manual air vent plug on all water coils
- 0.016" or 0.025" tube wall on water and evaporator coils
- 0.025" tube wall on steam coils
- 300 PSIG working pressure at 200°F, tested at 450 PSIG
- High efficiency aluminum fin surface

## FILTERS AND FILTER RACK

- Front access filter rack
- Standard 2" nominal throwaway filters
- 2" pleated filter (optional)

## FAN ASSEMBLY

- Forward curved (double width, double inlet) fans
- Statically and dynamically balanced
- Solid steel shafting
- Ball bearings with a minimum design average life (L50) of 100,000 hours



BLOWER COIL UNITS

## FAN MOTOR AND DRIVE

- NEMA design ODP motors
- 1750 RPM single speed, 60 Hertz
- Single phase motors with inherent thermal protection
- 3-phase motors (optional)
- Rigid mount adjustable motor base
- Standard cross section "V-belt" drive with 1.2 service factor
- Adjustable pitch motor pulley and fixed pitch blower pulley

## OPTIONAL ELECTRICAL FEATURES

- Motor wiring in conduit
- Motor starter (contactor with an overload for 3-phase; contactor for 1-phase), factory installed
- Door interlocking disconnect switch
- Hand off auto switch (HOA)
- Main fusing

## CERTIFICATIONS

- cETL Listed - Adherence to UL/ANSI Standard 1995
- AHRI 410 certified performance data

WEB SEARCH: [KSL](#)



### DIMENSIONAL DATA

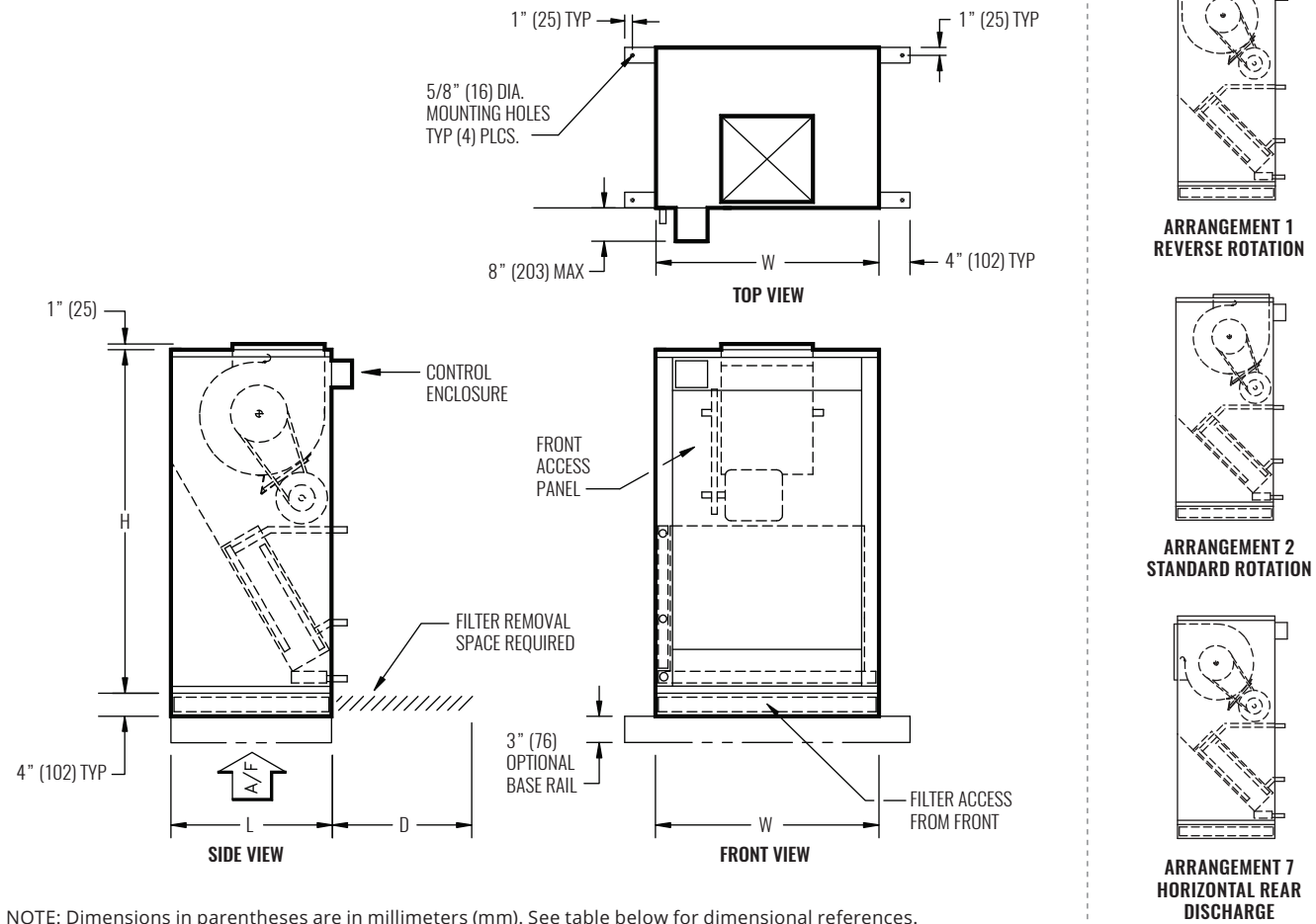

NOTE: Dimensions in parentheses are in millimeters (mm). See table below for dimensional references.

### PERFORMANCE AND DIMENSIONAL DATA

SIZE	PERFORMANCE	DIMENSIONS			
		H	W	L	D
UNIT SIZE	NOMINAL CFM				
8	800	46" (1168)	26" (660)	19" (483)	16" (406)
12	1200	46" (1168)	26" (660)	21" (533)	20" (508)
16	1600	54" (1372)	29" (737)	25" (635)	24" (610)
20	2000	54" (1372)	29" (737)	28" (711)	24" (610)
25	2500	60" (1524)	39" (991)	28" (711)	24" (610)
30	3000	60" (1524)	39" (991)	28" (711)	24" (610)

NOTES: Dimensions in parentheses are mm. All dimensions are  $\pm 1/4"$  (6mm). Metric values are soft conversions. Motor/drive location may be specified left or right hand. Standard control enclosure location matches motor/drive position. Provide sufficient clearance to access electrical controls and comply with all applicable codes and ordinances. Maximum total internal coil rows: 6. Left hand unit shown; right hand unit has CW and HW piping connections mirrored. Filter assembly runs the full length of the unit size.