

HORIZONTAL LOW PROFILE FAN COIL UNITS

SERIES A

Installation, Operation, and
Maintenance Manual

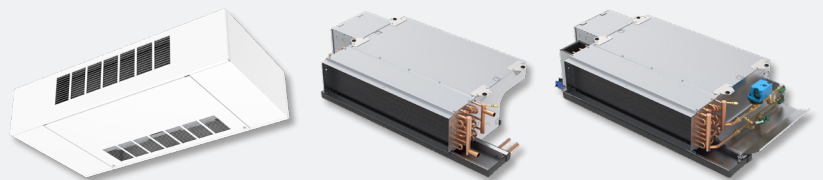

KHF - SERIES A FAN COIL UNITS

INSTALLATION, OPERATION, AND MAINTENANCE MANUAL

TABLE OF CONTENTS

SAFETY SYMBOLS & CONSIDERATIONS 3

SECTION ONE - RECEIPT & INITIAL INSTALLATION 4

KHF Series Features	4
Preface	4
Unpacking & Inspection	5
Handling & Installation	5
Coils	6
Cooling/Heating Medium Connections	7
Drain Pan	8
Auxiliary Drain Pans	8
Ductwork Connections	9
Electrical Connections	9
Electrical Enclosure	9
Telescoping Bottom Panel	10
Model KHFP Horizontal Fan Coil Optional	
Telescoping Bottom Panel Assembly,	
Typical Installation Instructions	10
Service & Clearance Requirements	11
Height Restricted Application	12
Width Restricted Application	13
External Space Requirements	14

SECTION TWO - START-UP 15

General	15
Cooling/Heating System	15
Air System Balancing	15
Motor & Fan Data	16
Water System Balancing	19
Controls Operation	19

SECTION THREE - NORMAL OPERATION & PERIODIC MAINTENANCE 20

General, Motor/Blower Assembly, and Fan Deck	20
Coil	21
Electric Resistance Heater Assembly	21
Electrical Wiring & Controls	21
Valves & Piping	21
Drain	21
Filters, Throwaway	22
Optional Item Installation	23
Condensate Pump	23
Current Switch Device	23
Differential Air Pressure Switch	24
Discharge Air Sensor	25
Low Temperature Cutout Control	26
Condensate Float Switch Installation	27
Replacement Parts	27
Unit Weights	28

SECTION FOUR - INSPECTION & START-UP CHECKLIST..... 29

Receiving & Inspection	29
Handling & Installation	29
Cooling/Heating Connections	29
Ductwork Connections	29
Electrical Connections	29
Unit Startup	29

SECTION FIVE - FAN RELAY BOARD 30

Installation, Operation and Maintenance	30
Installation - Mounting & Wiring	30
FRBii Inputs and Outputs	32
Jumpers and Test Points	33
Screw Terminal Signals and Checking Wire Harnesses	34

SECTION SIX - TROUBLESHOOTING 35

SAFETY SYMBOLS

The following symbols are used in this document to alert the reader to areas of potential hazard:



DANGER: Indicates an imminently hazardous situation which, if not avoided, will result in death or serious injury.



CAUTION: Identifies a hazard which could lead to damage to the machine, damage to other equipment and/or environmental pollution. Usually an instruction will be given, together with a brief explanation.



WARNING: Indicates a potentially hazardous situation which, if not avoided, could result in death or serious injury.



NOTE: Is used to highlight additional information which may be helpful to you.

SAFETY CONSIDERATIONS

The equipment covered by this manual is designed for safe and reliable operation when installed and operated within its design specification limits. To avoid personal injury or damage to equipment or property while installing or operating this equipment, it is essential that qualified, experienced personnel perform these functions using good judgment and safe practices. See the following cautionary statements.



ELECTRICAL SHOCK HAZARDS: All power must be disconnected prior to installation and servicing this equipment. More than one source of power may be present. Disconnect all power sources to avoid electrocution or shock injuries.



All assemblies must be adequately secured during lifting and rigging by temporary supports and restraints until equipment is permanently fastened and set in its final location.



MOVING PARTS HAZARDS: Motor and Blower must be disconnected prior to opening access panels. Motors can start automatically, disconnect all power and control circuits prior to servicing to avoid serious crushing or dismemberment injuries.



All unit temporary and permanent supports must be capable of safely supporting the equipment's weight and any additional live or dead loads that may be encountered. All supports must be designed to meet applicable local codes and ordinances.



HOT PARTS HAZARD: Electric Resistance heating elements must be disconnected prior to servicing. Electric Heaters may start automatically, disconnect all power and control circuits prior to servicing to avoid burns.



All fastening devices must be designed to mechanically lock the assembly in place without the capability of loosening or breaking away due to system operation and vibration.



Check that the unit assembly and component weights can be safely supported by rigging and lifting equipment.



Protect adjacent flammable materials when brazing. Use flame and heat protection barriers where needed. Have fire extinguisher available and ready for immediate use.

SECTION 1 - RECEIPT & INITIAL INSTALLATION

KHF - SERIES A FEATURES

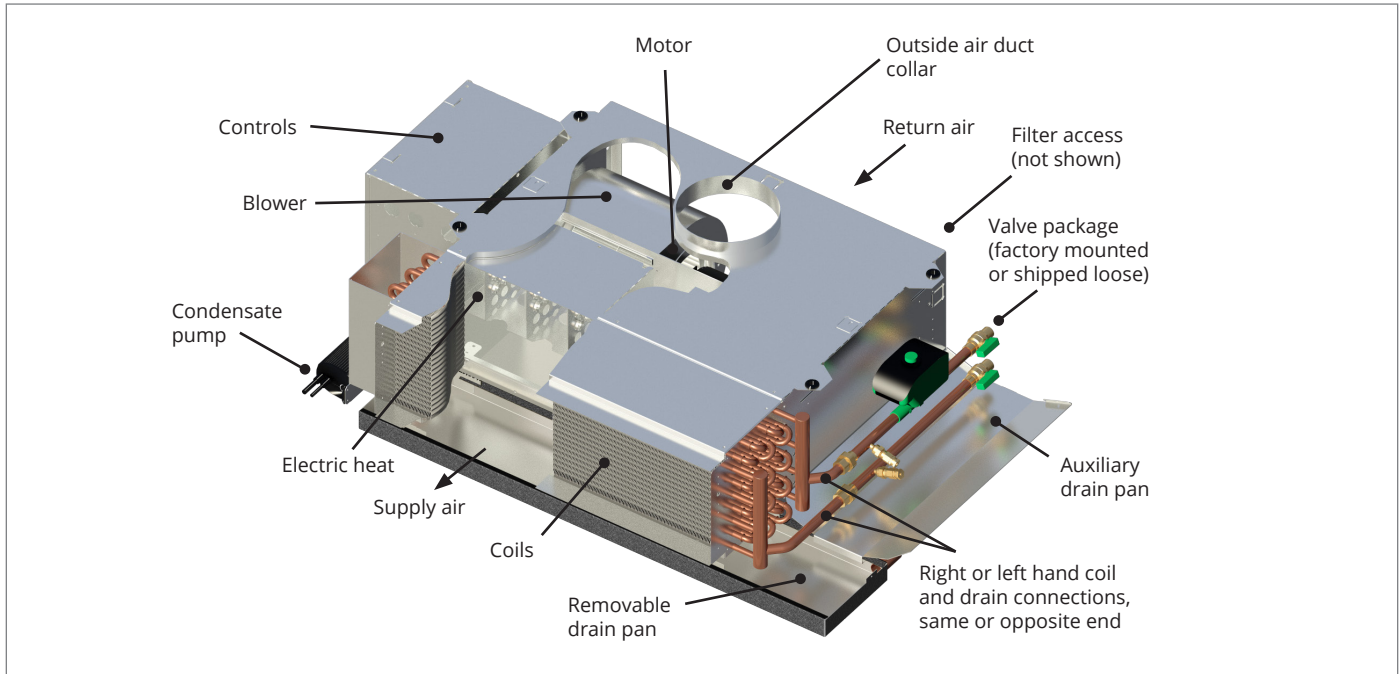

PREFACE

Krueger fan coils represent a prudent investment which can, with proper installation, operation, and regular maintenance, give trouble-free operation and long service.

Your equipment is initially protected under the manufacturer's standard warranty; however, this warranty is provided under the condition that the steps outlined in this manual for initial inspection, proper installation, regular periodic maintenance, and everyday operation of the equipment be followed in detail. This manual should be fully reviewed in advance of any actual work being done on the equipment. Should any questions arise, please contact your local Sales Representative or the factory BEFORE proceeding.

The equipment covered by this manual is available with a vast variety of options and accessories. Consult the approved unit submittal, order acknowledgement, and other manuals for details on the options and accessories provided with the equipment on each project.

The manufacturer assumes no responsibility for personal injury or property damage resulting from improper or unsafe practices during the handling, installation, service, or operation of any equipment.



No attempt should be made to handle, install, or service any unit without following safe practices regarding mechanical equipment.



All power must be disconnected before any installation or service should be attempted. More than one power source may be supplied to a unit. Power to remote mounted control devices may not be supplied through the unit. Never wear bulky or loose fitting clothing when working on any mechanical equipment. Gloves should only be worn when required for proper protection from heat or other possible injury. Safety glasses or goggles should always be worn when drilling, cutting, or working with chemicals such as refrigerants or lubricants.



Never pressurize any equipment beyond specified operating pressures. Always pressure test with some inert fluid or gas such as clear water or dry nitrogen to avoid possible damage or injury in the event of a leak or component failure during testing.



Always protect adjacent flammable material when welding, brazing or soldering. Use suitable heat shield material to contain sparks or drops of solder. Have fire extinguisher available for use when welding or brazing.

UNPACKING & INSPECTION

All units are carefully inspected at the factory throughout the manufacturing process under a strict detailed quality assurance program, and where possible, all major components and subassemblies are carefully tested for proper operation and verified to be in full compliance with the factory manufacturing documents. Customer furnished components such as control valves, switches and DDC controls are not factory tested.

Each unit is carefully packaged for shipment to avoid damage during normal transport and handling. The equipment should always be stored in a dry place in the proper orientation as marked on the carton.

All shipments are made F.O.B. factory and it is the responsibility of the receiving party to inspect the equipment upon arrival. Any obvious damage to the carton and/or its contents should be recorded on the bill of lading and a claim should be filed with the freight carrier.

After determining the condition of the carton exterior, carefully remove each unit from the carton and inspect for hidden damage. At this time check to make sure that "furnished only" items such as switches, thermostats, etc., are accounted for. Any hidden damage should be recorded and immediately reported to the carrier and a claim must be filed. In the event a claim for shipping damage is filed, the unit, shipping carton, and all packing must be retained for physical inspection by the freight carrier. All equipment should be stored in the factory shipping carton with internal packing in place until installation.

At the time of receipt, the equipment type and arrangement should be verified against the order documents. Should any discrepancy be found, the local Sales Representative should be notified immediately so that the proper action may be instituted. Should any question arise concerning warranty repairs, the factory must be notified BEFORE any corrective action is taken. Where local repairs or alterations can be accomplished, the factory must be fully informed as to the extent and expected cost of those repairs before work is begun. Where factory operations are required, the factory must be contacted for authorization to return equipment and a Return Authorization Number will be issued. Unauthorized return shipments of equipment and shipments not marked with an authorization number will be refused. In addition, the manufacturer will not accept any claims for unauthorized expenses.

CODE COMPLIANCE

This equipment has been manufactured and certified in accordance with UL 1995-Standard for Safety, Heating and Cooling Equipment (CAN/CSA C22.2 NO 236- M90) and bears the Electrical Testing Laboratories (ETL) Mark under ETL File No.: 3036742-002.

HANDLING & INSTALLATION

While all equipment is designed for durability and fabricated for sturdy construction and may present a rugged appearance, great care must be taken to assure that no force or pressure be applied to the coil, piping or drain stub-outs during handling. Also, depending on the options and accessories, some units could contain delicate components that may be damaged by improper handling. Wherever possible, all units should be maintained in an upright position and handled by the chassis as close as possible to the mounting point locations.

In the case of a full cabinet unit, the unit must obviously be handled by the exterior casing. This is acceptable providing the unit is again maintained in an upright position and no impact forces are applied that may damage internal components, access panels, or painted surfaces. The equipment covered in this manual IS NOT suitable for outdoor installations. The equipment should never be stored or installed where it may be subjected to a hostile environment such as rain, snow, or extreme temperatures.

During and after installation, special care must be taken to prevent foreign material such as paint, plaster, and drywall dust from being deposited in the drain pan or on the motor or blower wheels. Failure to do so may have serious adverse effects on unit operation and in the case of the motor and blower assembly, may result in immediate or premature failure. All manufacturers' warranties are void if foreign material is allowed to be deposited on the motor or blower wheels of any unit. Some units and/or job conditions may require some form of temporary covering during construction.

While the manufacturer does not become involved in the design and selection of support methods and components, it should be noted that unacceptable system operating characteristics and/or performance may result from improper or inadequate unit structural support. In addition, adequate clearance must be provided for service and removal of the equipment and its accessory components. Anchoring the equipment in place is accomplished by using the mounting points provided and positioning the unit to maintain the unit on a LEVEL plane. The drain pan is internally sloped toward the outlet connection. Care must be taken to insure that the unit drain pan does not slope away from the outlet connection. All units are supplied with integrated hanger brackets with optional grommet isolators and brass inserts for use with 3/8" all thread hanger rod.



The unit's drain pan is factory sloped toward the unit's drain pan drain connection when the unit is installed level and plumb.

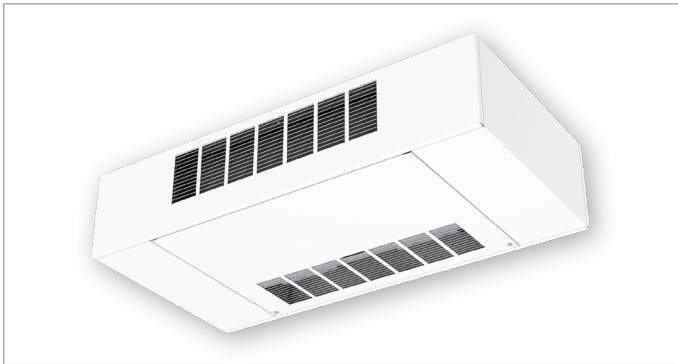

KHFE

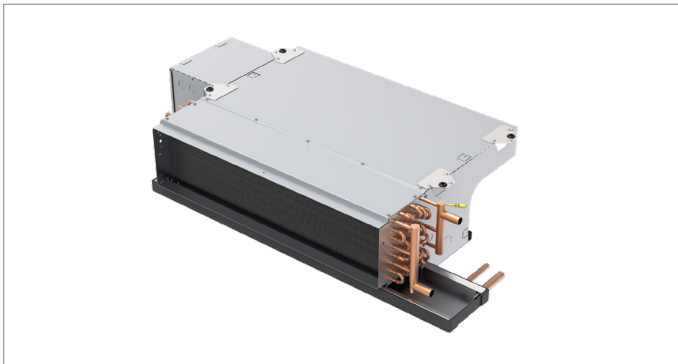

KHFH

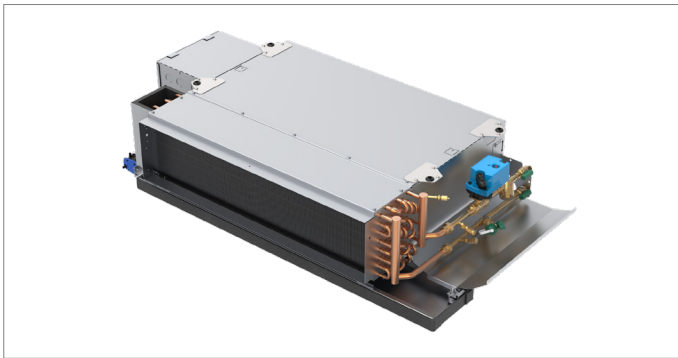

KHFP

COILS

All fan coils are available in 2 or 4 pipe configurations. Heating coils are available in reheat or preheat position. Heating and cooling coils are available with right, left or opposite side connections.

Verify that the proper types of service are actually provided to the unit. On units with steam heating coils, the maximum steam pressure applied to the unit should never exceed 15 PSIG. The drain piping and steam trap should be sized and routed to allow for proper condensate flow. The electrical service to the unit should be compared to the unit nameplate to verify compatibility. The routing and sizing of all piping, and the type and sizing of all wiring and other electrical components such as circuit breakers, disconnect switches, etc., should be determined by the individual job requirements and should not be based on the size and/or type of connection provided on the equipment. All installations should be made in compliance with all governing codes and ordinances. Compliance with all codes is the responsibility of the installing contractor.

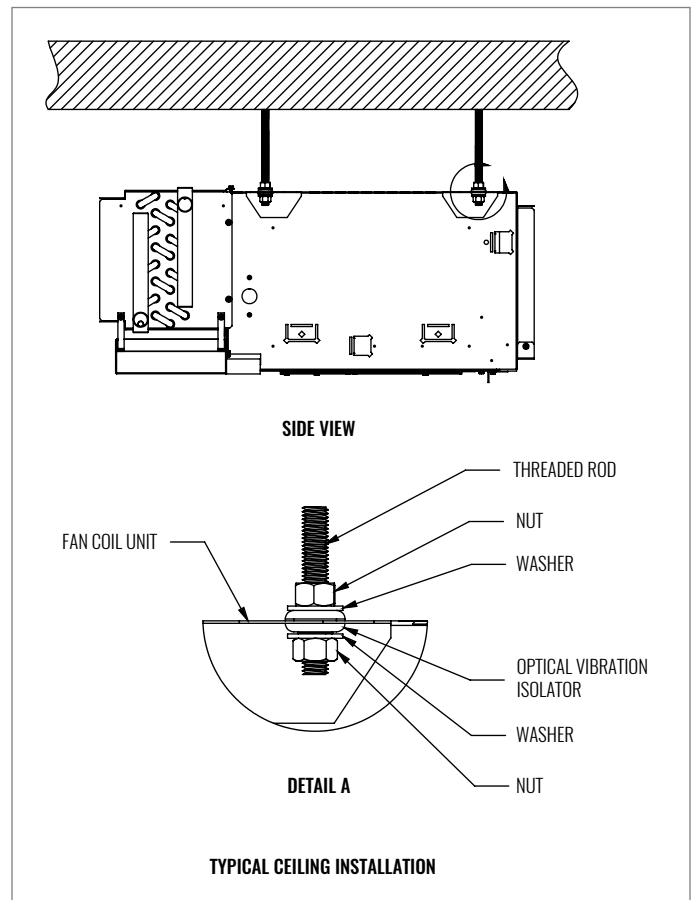

Figure 1: Typical ceiling installation

COOLING/HEATING MEDIUM CONNECTIONS



Toxic residues and loose particles resulting from manufacturing and field piping techniques such as joint compounds, soldering flux, and metal shavings may be present in the unit and the piping system. Not for use with domestic or potable water systems.

Submittals and Product Catalogs detailing unit operation, controls, and connections should be thoroughly reviewed BEFORE beginning the connection of the various cooling and/or heating mediums to the unit.

All accessory valve packages should be installed as required, and all service valves should be checked for proper operation. To prevent condensation accumulation and runoff, chilled water valve packages must be insulated, or preferably, utilize a factory-provided auxiliary drip tray.



Before brazing or sweating valve packages and their components into place, it is critical to pre-check all valve package clearances in relation to the auxiliary drain pan. If the auxiliary drain pan cannot be properly affixed to the auxiliary drain pan support bracket, adjust valve package component angles until proper clearance is achieved.

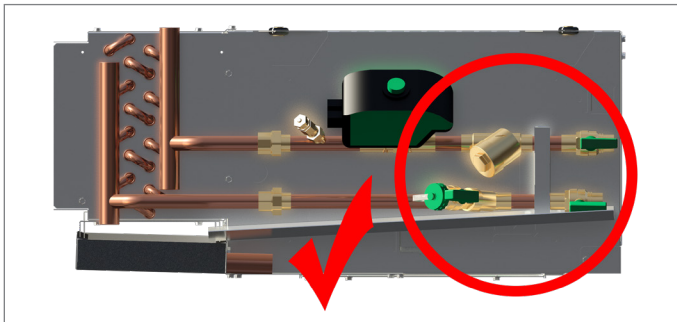

If coil and valve package connections are to be made with "sweat" or solder joint, care should be taken to assure that no components in the valve package are subjected to a high temperature which may damage seals or other materials. Many two-position electric control valves, depending on valve operation, are provided with a manual-opening lever. This lever should be placed in the "open" position during all soldering or brazing operations. Valve bodies should be wrapped with a wet rag to help dissipate heat encountered during brazing.

If the valve package connection at the coil is made with a union, the coil side of the union must be prevented from twisting ("backed up") during tightening to prevent damage to the coil tubing. Over-tightening must be avoided to prevent distorting the union seal surface and destroying the union. Due to the diversity of valve packages for this product, install the valve packages with no leaks or interference between components during operation and maintenance. In the case of field installed valves and piping, the chilled water valve cluster (or metering device on DX units) should be installed in such a way that any dripping or sweating is contained in the auxiliary drain pan or other device. Valves and TXV's should be secured or supported to avoid damage to coil headers or distributor tubes. All valves, pipes, and components must be sufficiently supported to ensure structural integrity and proper operation of the unit.

After the connections are completed, the system should then be tested for leaks. Since some components are not designed to hold pressure with a gas, hydronic systems should be tested with water.



All water coils must be protected from freezing after initial filling with water. Even if the system is drained, unit coils may still hold enough water to cause damage when exposed to temperatures below freezing.

Refrigerant systems should be tested with dry nitrogen rather than air to prevent the introduction of moisture into the system. In the event that leaking or defective components are discovered, the Sales Representative must be notified BEFORE any repairs are attempted. All leaks should be repaired before proceeding with the installation.

DRAIN PAN

Standard drain pans are externally insulated, single wall galvanized steel and can be equipped with a secondary drain connection. The KHF drain pan is easily removable for cleaning. See illustration below. Auxiliary drip pan to catch condensed moisture from valves and piping must be sloped toward the drain pan.

The condensate drain pan can be removed without requiring common hand tools. The drain pan is secured to the unit by four sheet metal tabs that slide into four respective slots on the drain pan.

Prior to removing the drain pan, make sure all accessories and field connections have been appropriately disconnected from the drain pan. The drain pan can be removed in three steps. First, push the drain pan engagement lever to unlock the drain pan from the coil. Next, while continuing to push the lever, support the weight of the drain pan and slide the drain pan towards the drain connection. After the drain pan slides approximately 1.5 inches, it will be completely disengaged from the coil. Lastly, support the weight of the drain pan and safely lower the drain pan for servicing. Reinstall prior to unit startup.

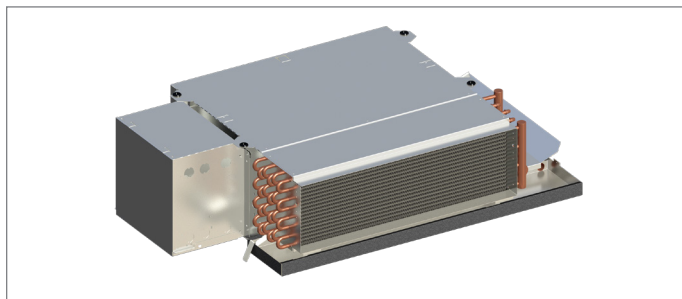

Figure 2a

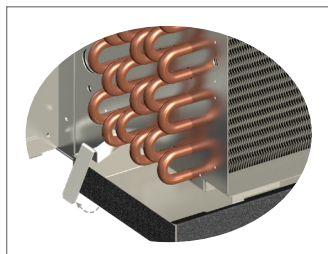

Figure 2b

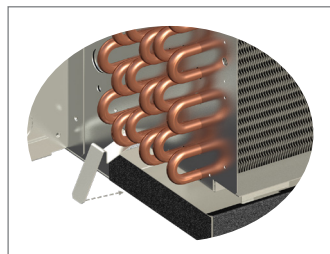

Figure 2c

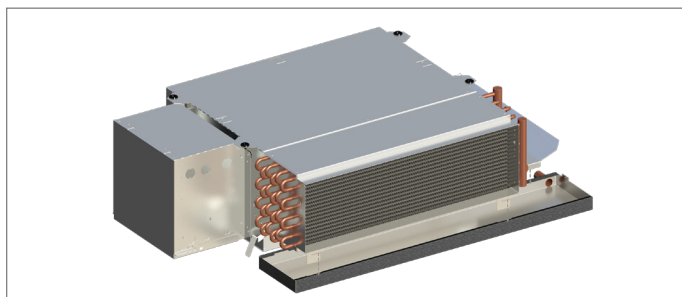

Figure 2d | Figures 2a-2d: Typical drain pan removal

AUXILIARY DRAIN PANS

Mounted directly to the unit drain pan, AUXILIARY DRAIN PANS may also be secured by the mounting holes to field supports or to the unit coil utilizing pipe hanger wire, plastic ties, or metal strapping.

Prior to removing the auxiliary drain pan, make sure all accessories have been appropriately disconnected from the auxiliary drain pan. The auxiliary drain pan can be removed in three steps. First, remove the two screws that attached the auxiliary drain pan to the support bracket near the inlet of the unit. Next, support the weight of the auxiliary drain pan and slide the auxiliary drain pan towards the discharge of the unit so the auxiliary drain pan lip will clear the drain pan lip. After the auxiliary drain pan slides approximately 0.75 inches, the auxiliary drain pan will be free from the drain pan. Lastly, support the weight of the auxiliary drain pan and safely lower for servicing. Reinstall prior to unit startup.

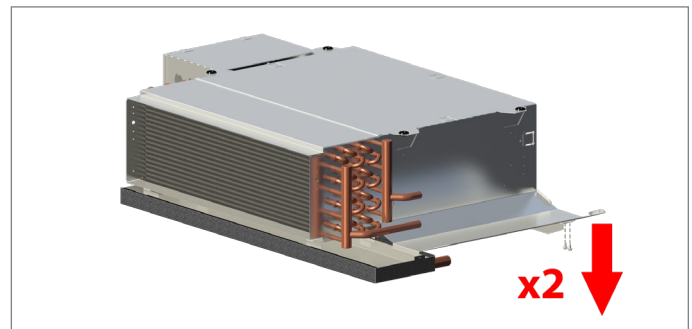

Figure 3a

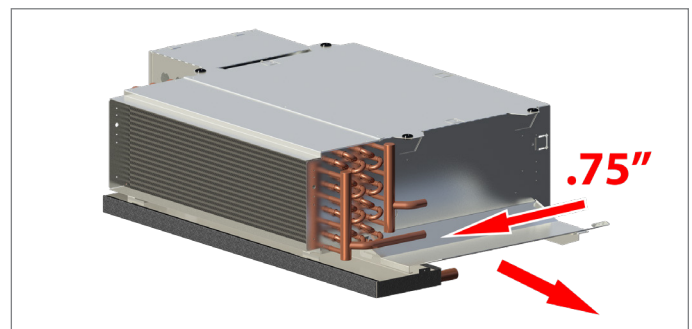

Figure 3b

Figure 3a-3b: Typical auxiliary drain pan removal

DUCTWORK CONNECTIONS

All ductwork and/or supply and return grilles should be installed in accordance with the project plans and specifications. If not included on the unit or furnished from the factory, Krueger supply and return grilles are available in a variety of types.

Units can be configured from the factory with duct collars for attaching ductwork. The factory suggests using galvanized sheet metal ductwork or a flexible canvas attached to the duct collars using sheet metal screws. Duct connections should follow SMACNA standards and national and local codes.

All units must be installed in non-combustible areas. Some models are designed to be connected to ductwork with a MINIMUM amount of external static pressure. Consult the approved submittals and the product catalog for unit external static pressure limitations.

Units provided with outside air for ventilation should have some form of low temperature protection to prevent coil freeze-up.

It should be noted that none of these methods would adequately protect a coil in the event of power failure. The safest method of freeze protection is to use glycol in the proper percent solution for the coldest expected air temperature.

The manufacturer assumes no responsibility for undesirable system operation due to improper design, equipment or component selection, and/or installation of ductwork, grilles, and other field supplied components.

ELECTRICAL CONNECTIONS

The unit nameplate lists the unit electrical characteristics such as the required supply voltage, fan and heater amperage and required circuit ampacities. The unit wiring diagram shows all unit and field wiring. Since each project is different and each unit on a project may be different, the installer must be familiar with the wiring diagram and nameplate on the unit BEFORE beginning any wiring. This unit is not acceptable for installation in hazardous/explosive areas.

ELECTRICAL ENCLOSURE

The electrical control enclosure provides access to the electrical compartment. This compartment houses all electric heat and control components. Terminal strips are furnished for simple power and control wiring connections. Multiple knockouts allow wiring entries from either side of the compartment.

All components furnished for field installation, by either the factory or the controls contractor should be located and checked for proper function and compatibility. All internal components should be checked for shipping damage. After installation and before energizing the unit, verify voltage and check that all electrical connections are tight. Electrical connections should be periodically checked for tightness.

Any devices such as fan switches or thermostats that have been furnished from the factory for field installation must be wired in strict accordance with the applicable wiring diagrams. Failure to do so could result in personal injury or damage to components and will void all manufacturers' warranties.

All field wiring should be done in accordance with governing codes and ordinances. Any modification of the unit wiring without factory authorization will result in voiding of all factory warranties and will nullify any agency listings.

The manufacturer assumes no responsibility for any damages and/or injuries resulting from improperly field installed or wired components.

This unit is listed to UL/CSAS standards. All modifications to line voltage wiring must be performed in accordance with the NEC and inspected by ETL to maintain product listing. Unauthorized modification to any wiring may impact unit performance and void ETL listing and/or product warranty.

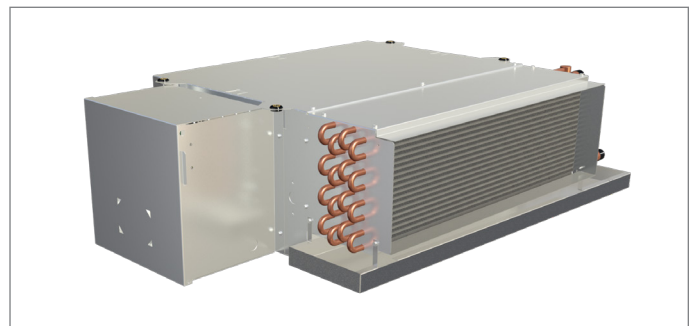

Figure 4: Electrical enclosure

KHF HORIZONTAL FAN COIL

OPTIONAL TELESCOPING BOTTOM PANEL ASSEMBLY, TYPICAL INSTALLATION INSTRUCTIONS

TELESCOPING BOTTOM PANEL

The telescoping bottom panel allows for fully recessing the unit while permitting service access into the ceiling plenum. The architectural ceiling panel is finished with a durable powder coat paint.



Portions of the inlet louver not directly below unit inlet may require covering in the field on applications where infiltration of ceiling plenum air into space is undesired. Telescoping skirt and collar assembly must be field adjusted to assure a proper fit between filter frame and louvered inlet panel assembly. Refer to assembly submittal drawings for specific dimensions.

Drawings are subject to change without notice. Refer to www.krueger-hvac.com for current submittal drawings.

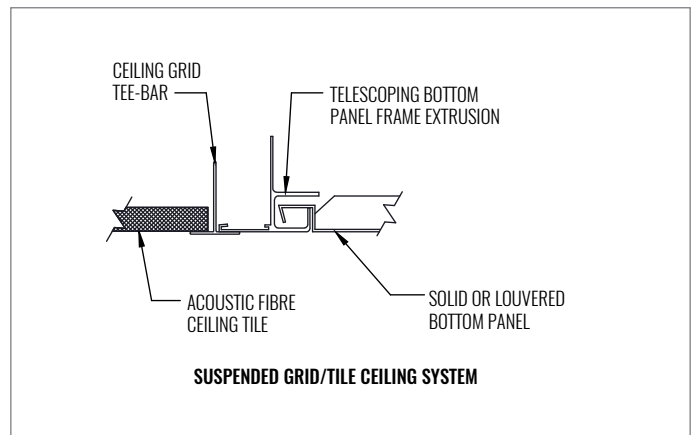
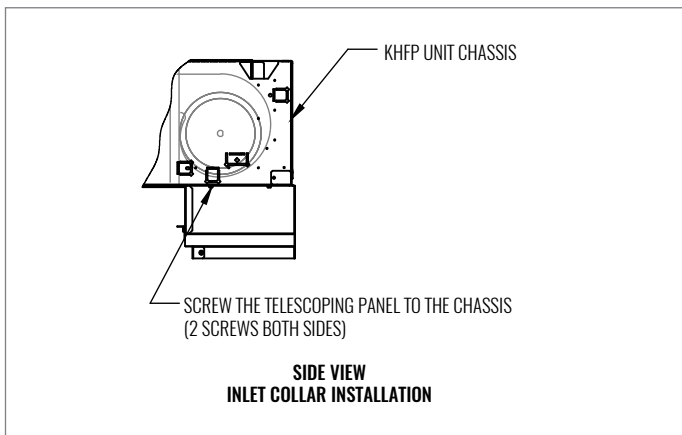
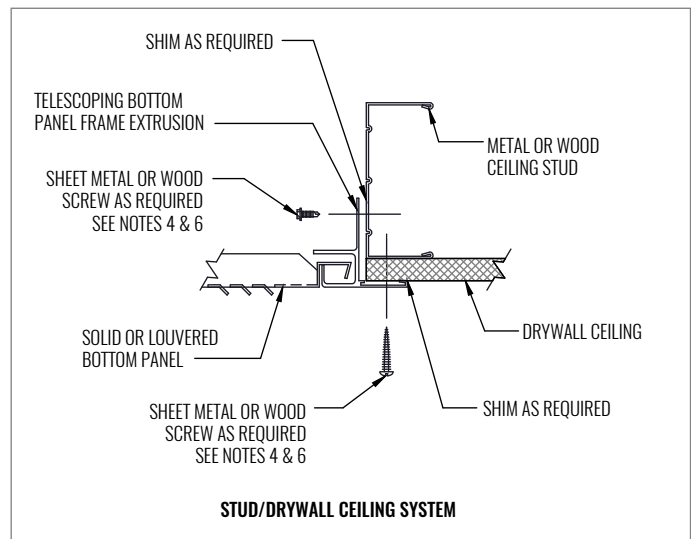
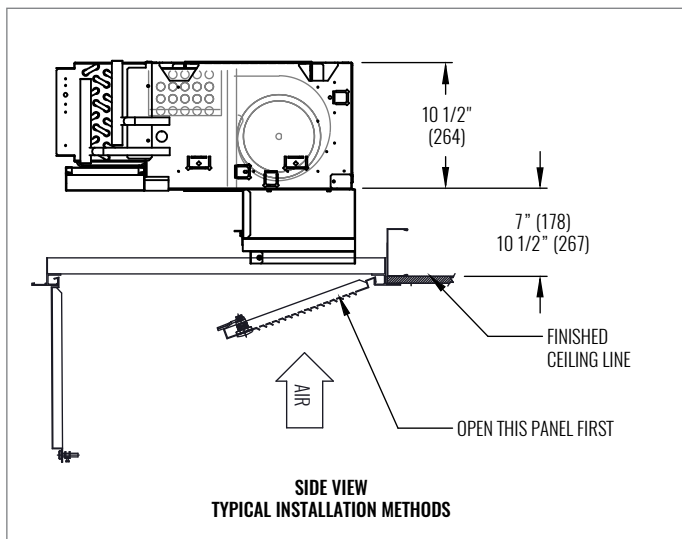

NOTE: Ceiling tee bar grid may not support telescoping bottom panel assembly. Bottom panel assembly may require independent support.

TABLE 1: TELESCOPING BOTTOM PANEL WEIGHTS (LBS./KG)

DESCRIPTION	UNIT SIZE							
	02	03	04	06	08	09	10	12
Telescoping bottom panel	10 (5)	11 (5)	12 (5)	14 (6)	16 (7)	17 (8)	20 (9)	21 (10)

SERVICE AND CLEARANCE REQUIREMENTS

HORIZONTAL, LOW PROFILE EXPOSED UNITS

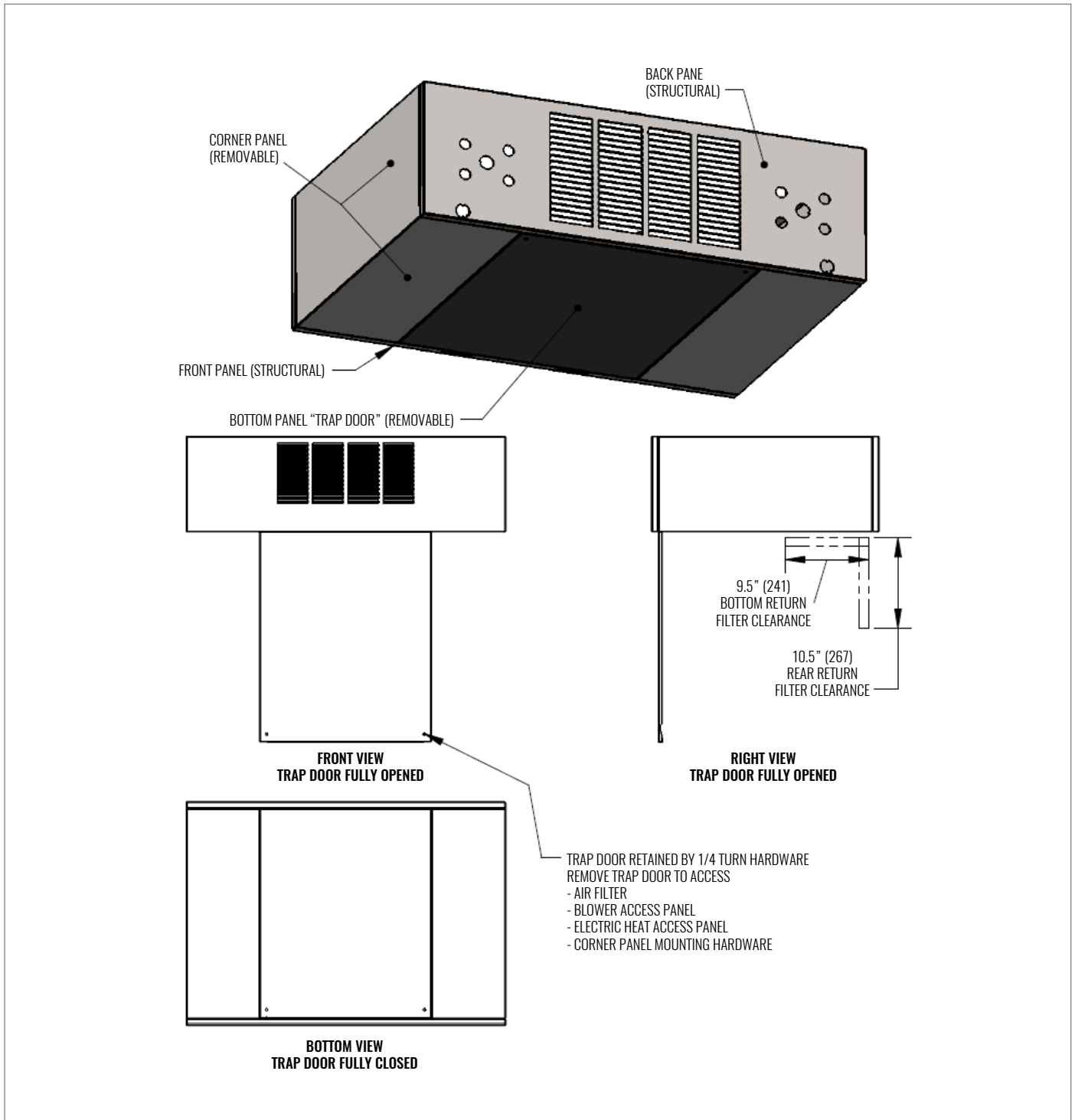

SERVICE AND CLEARANCE REQUIREMENTS: HEIGHT RESTRICTED APPLICATION

HORIZONTAL, LOW PROFILE EXPOSED UNITS

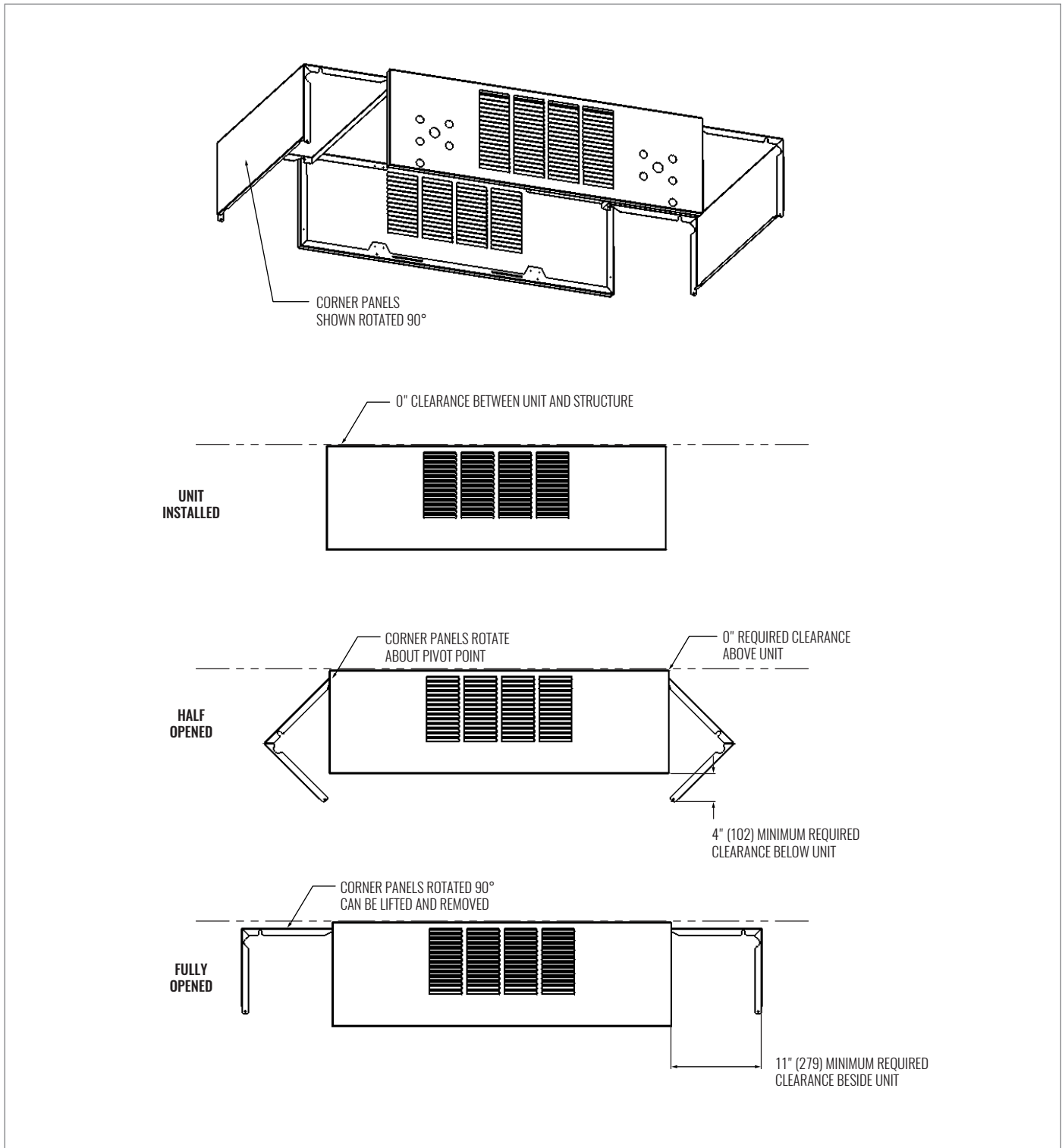

SERVICE AND CLEARANCE REQUIREMENTS: WIDTH RESTRICTED APPLICATION

HORIZONTAL, LOW PROFILE EXPOSED UNITS

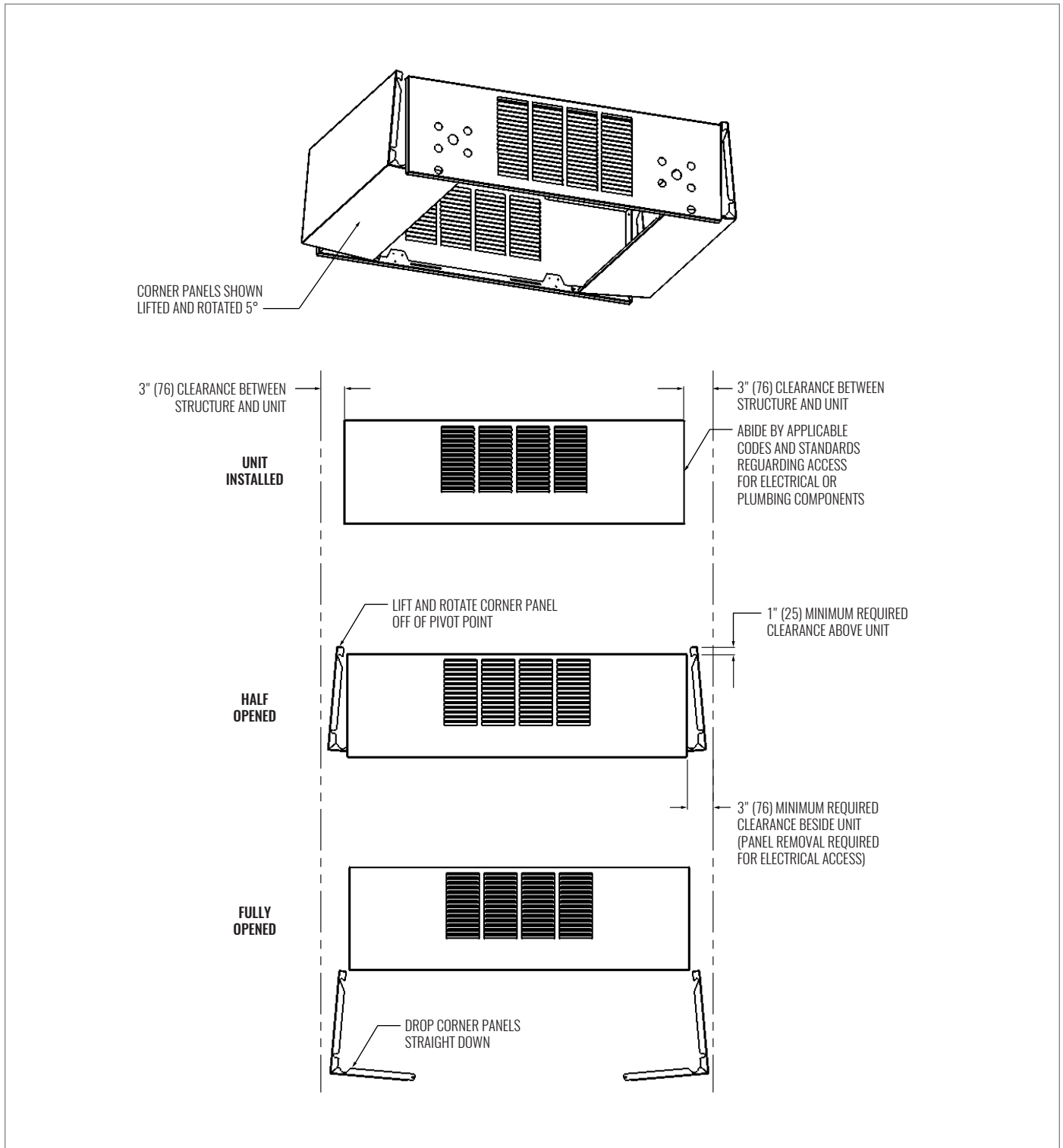

SERVICE AND CLEARANCE REQUIREMENTS: EXTERNAL SPACE REQUIREMENTS

HORIZONTAL, LOW PROFILE PLENUM AND FREE RETURN

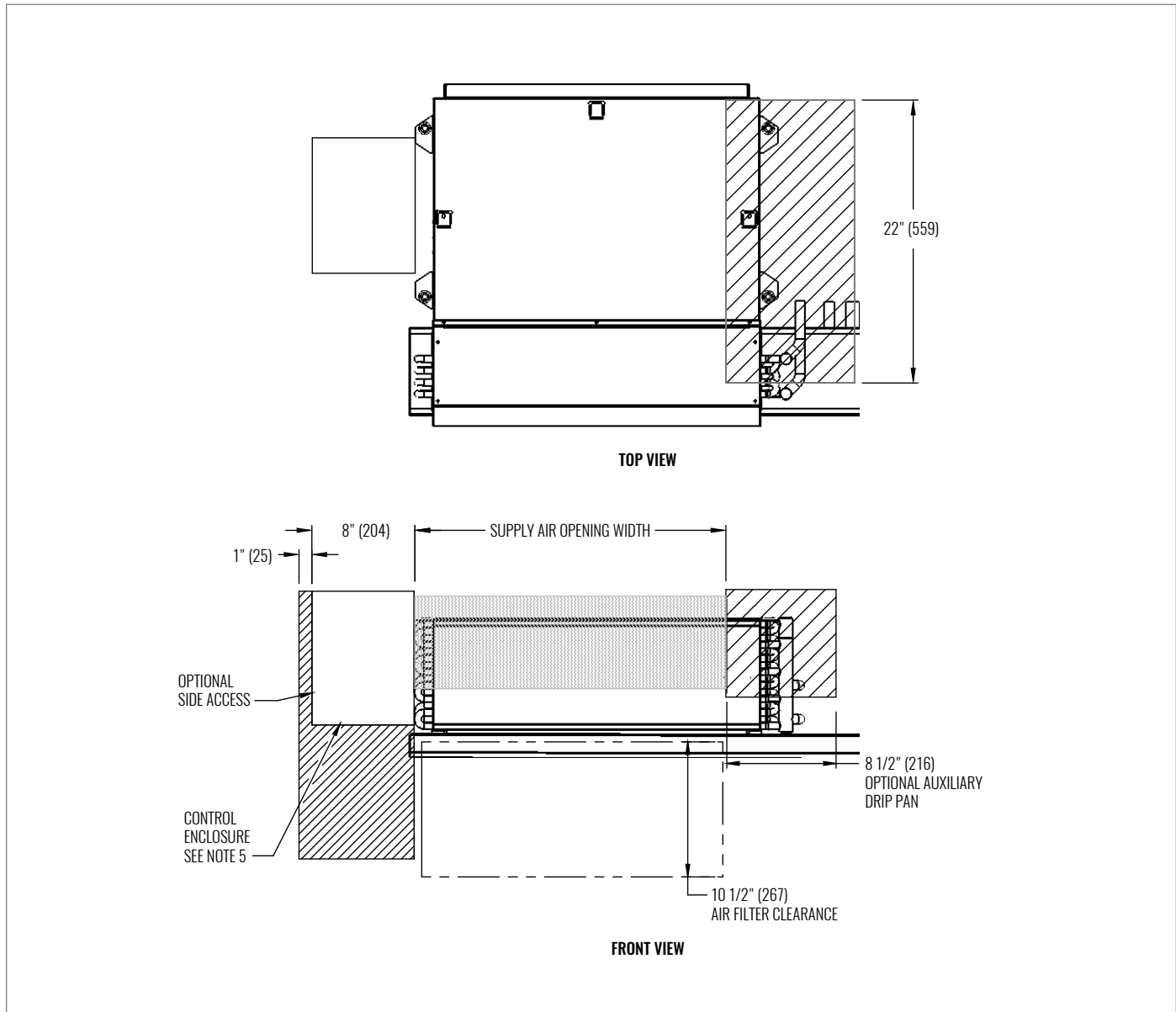

NOTES:

1. All chilled water piping that projects beyond the condensate pan or the optional auxiliary drip pan must be field insulated by others.
2. Auxiliary drip pan shown above is optional, and is mounted on the outlet side of the drain pan.
3. Drain pan is installed with the outlet tube(s) on cooling coil connection end of coil on 4-pipe units with optional opposite end connection.
4. Dimensions shown on this drawing apply to standard CW and HW valve packages. Refer to the Piping Package Catalog for valve package code details. Contact factory for details on valve packages using non-standard or customer furnished components.
5. Provide sufficient clearance to access electrical components and comply with all applicable codes and ordinances.

SECTION TWO - START-UP

GENERAL

Before beginning any start-up operation, the startup personnel should familiarize themselves with the unit, options and accessories, and control sequence to understand the proper system operation. All personnel should have a good working knowledge of general start-up procedures and have the appropriate start-up and balancing guides available for consultation.

The initial step in any startup operation should be a final visual inspection. All equipment, plenums, ductwork, and piping should be inspected to verify that all systems are complete and properly installed and mounted, and that no debris or foreign articles such as paper or drink cans are left in the units or other areas. Each unit should be checked for loose wires, free blower wheel operation, and loose or missing access panels or doors. Except as required during start-up and balancing operations, no fan coil units should be operated without all the proper ductwork attached, supply and return grilles in place, and all access doors and panels in place and secure. A clean filter of the proper size and type must also be installed. Failure to do so could result in damage to the equipment or building and furnishings, and/or void all manufacturers' warranties.

Fan coils are not intended for temporary heat/cool or ventilation. Units are not designed or equipped to operate in dusty construction environments. Operation of the units in conditions outlined above could result in damage to the equipment or building and furnishings and/or void all manufacturer's warranties.

AIR SYSTEM BALANCING

All ductwork must be complete and connected, and all grilles, filters, access doors and panels must be properly installed to establish actual system operating conditions BEFORE beginning air balancing operations.

Each individual unit and attached ductwork is a unique system with its own operating characteristics. For this reason, air balancing is normally done by balance specialists who are familiar with all procedures required to properly establish air distribution and fan system operating conditions. These procedures should not be attempted by unqualified personnel. Some selections may require air balancing in the field.

After the proper system operation is established, the actual unit air delivery and the actual fan motor amperage draw for each unit should be recorded in a convenient place for future reference such as the inspection, installation, & start-up check sheet, a copy of which is provided on the back of this manual. Contact the Sales Representative or the factory for additional copies of this sheet.

COOLING/HEATING SYSTEM

Prior to the water system start-up and balancing, the chilled/hot water systems should be flushed to clean out dirt and debris, which may have collected in the piping during construction. During this procedure, all unit service valves must be in the closed position. This prevents foreign matter from entering the unit and clogging the valves and metering devices. Strainers should be installed in the piping mains to prevent this material from entering the units during normal operation.

During system filling, air venting from the unit is accomplished by the use of the standard manual, or optional automatic, air vent fitting installed on the coil. In the case of the manual air vent fitting, the screw should be turned counterclockwise no more than 1-½ turns to operate the air vent. Automatic air vents may be unscrewed one turn counterclockwise to speed initial venting but should be screwed in for automatic venting after start-up operations. Check to ensure that no leaks are prevalent at the coils, coil connections, piping packages, etc.



The air vent provided on the unit is not intended to replace the main system air vents and may not release air trapped in other parts of the system. Inspect the entire system for potential air traps and vent those areas as required, independently. In addition, some systems may require repeated venting over a period of time to properly eliminate air from the system.

MOTOR AND FAN DATA

TABLE 2A: PSC MOTORS - KHFP, KHFE							
UNIT SIZE	PSC MOTOR HP (QTY)	# OF FANS	FAN SPEED	WATTS ²	115 VOLTS	208/230 VOLTS	277 VOLTS
					AMPS ¹	AMPS ¹	AMPS ¹
02	(1) 1/30 ³	1	High	55	0.5	N/A	N/A
			Medium	40			
			Low	36			
03	(1) 1/30 ³	1	High	61	0.5	N/A	N/A
			Medium	45			
			Low	40			
04	(1) 1/20	2	High	75	0.8	0.4	0.5
			Medium	65			
			Low	58			
06	(1) 1/20	2	High	80	0.8	0.4	0.5
			Medium	68			
			Low	56			
08	(1) 1/10	2	High	122	1.1	0.6	0.5
			Medium	83			
			Low	66			
09	(1) 1/10	2	High	127	1.1	0.6	0.5
			Medium	86			
			Low	66			
10	(2) 1/20	4	High	148	1.6	0.8	1
			Medium	128			
			Low	110			
12	(2) 1/20	4	High	160	1.6	0.8	1
			Medium	139			
			Low	115			

NOTES:

1. Motor electrical data is nameplate data.
2. Watts are based on an KHFP with PSC motor, 3 row coil, 12FPI, 1" throwaway filter, 0.05" ESP at 115V.
3. PSC motors are not available in 208-277V on SZ02 and SZ03.
4. Motor data is subject to change and should not be used for submittal purposes.

MOTOR AND FAN DATA

TABLE 2B: PSC MOTORS, MODEL KHFH							
UNIT SIZE	PSC MOTOR HP (QTY)	# OF FANS	FAN SPEED	WATTS ²	115 VOLTS	208/230 VOLTS	277 VOLTS
					AMPS ¹	AMPS ¹	AMPS ¹
02	(1) 1/30 ³	1	High	55	0.5	N/A	N/A
			Medium	40			
			Low	36			
03	(1) 1/30 ³	1	High	61	0.5	N/A	N/A
			Medium	45			
			Low	40			
04	(1) 1/20	2	High	75	0.8	0.4	0.5
			Medium	65			
			Low	58			
06	(1) 1/10	2	High	121	1.1	0.6	0.5
			Medium	84			
			Low	66			
08	(1) 1/6	2	High	224	2.1	1.1	0.9
			Medium	140			
			Low	66			
09	(1) 1/6	2	High	230	2.1	1.1	0.9
			Medium	139			
			Low	67			
10	(2) 1/10	4	High	226	2.2	1.2	1
			Medium	154			
			Low	128			
12	(2) 1/10	4	High	248	2.2	1.2	1
			Medium	171			
			Low	133			

NOTES:

1. Motor electrical data is nameplate data.
2. Watts are based on an KHFH with PSC motor, 3 row coil, 12FPI, 1" throwaway filter, 0.05" ESP at 115V.
3. PSC motors are not available in 208-277V on SZ02 and SZ03.
4. Motor data is subject to change and should not be used for submittal purposes.

MOTOR AND FAN DATA

TABLE 3: EC MOTORS										
UNIT SIZE	FAN SPEED	EC MOTOR HP (QTY)	# OF FANS	WATTS ² (STD/HS)	AMPS ^{1,3}					
					115 VOLTS		208/230 VOLTS		277 VOLTS	
					3-SPEED (STD/HS)	2-10VDC	3-SPEED (STD/HS)	2-10VDC	3-SPEED (STD/HS)	2-10VDC
02	High	(1) 1/4	1	32 / 45	0.7 / 1.0	0.9	0.5 / 0.6	0.5	0.4 / 0.5	0.5
	Medium			21 / 36						
	Low			14 / 26						
03	High	(1) 1/4	1	35 / 59	1.0 / 1.5	1.1	0.6 / 0.9	0.7	0.5 / 0.8	0.6
	Medium			23 / 43						
	Low			16 / 33						
04	High	(1) 1/4	2	50 / 75	1.5 / 1.8	1.2	0.9 / 1.1	0.8	0.8 / 0.9	0.6
	Medium			33 / 56						
	Low			21 / 41						
06	High	(1) 1/4	2	104 / 132	2.6 / 3.1	2.0	1.6 / 1.9	1.2	1.3 / 1.6	1.0
	Medium			62 / 89						
	Low			36 / 62						
08	High	(1) 1/4	2	91 / 122	2.3 / 2.9	2.0	1.4 / 1.7	1.2	1.2 / 1.5	1.0
	Medium			54 / 90						
	Low			31 / 62						
09	High	(1) 1/4	2	119 / 182	3.7 / 4.5	2.7	2.3 / 2.7	1.6	1.9 / 2.3	1.4
	Medium			72 / 116						
	Low			39 / 77						
10	High	(2) 1/4	4	142 / 207	3.9 / 5.1	3.1	2.3 / 3.1	1.9	2.0 / 2.6	1.6
	Medium			91 / 139						
	Low			54 / 104						
12	High	(2) 1/4	4	143 / 209	3.2 / 4.5	3.5	2.0 / 2.7	2.1	1.6 / 2.3	1.8
	Medium			92 / 152						
	Low			56 / 105						

NOTES:

1. Motor electrical data is nameplate data.
2. Watts are based on an KHFP with 3-speed EC motor, 3 row coil, 12FPI, 1" throwaway filter, 0.05" ESP at 115V.
3. For neutral conductor sizing, multiply AMPS by 1.73.
4. Motor data is subject to change and should not be used for submittal. Refer to unit submittal for actual ratings.

WATER SYSTEM BALANCING

A complete knowledge of the hydronic system, its components, and controls is essential to proper water system balancing and this procedure should not be attempted by unqualified personnel. The system must be complete and all components must be in operating condition BEFORE beginning water system balancing operations.

Each hydronic system has different operating characteristics depending on the devices and controls in the system. The actual balancing technique may vary from one system to another.

After the proper system operation is established, the appropriate system operating conditions such as various water temperatures and flow rates should be recorded in a convenient place for future reference.

Before and during water system balancing, conditions may exist which can result in noticeable water noise or undesired valve operation due to incorrect system pressures. After the entire system is balanced, these conditions will not exist on properly designed systems.

CONTROLS OPERATION

Before proper control operation can be verified all other systems must be in proper operation. The correct water and air temperatures must be present for the control function being tested. Some controls and features are designed to not operate under certain conditions.

A wide range of controls and electrical options and accessories may be used with the equipment covered in this manual. Consult the approved unit submittals, order acknowledgement, and other manuals for detailed information regarding each individual unit and its controls. Since controls and features may vary from one unit to another, care should be taken to identify the controls to be used on each unit and their proper control sequence. Information provided by component manufacturers regarding installation, operation, and maintenance of their individual controls is available upon request.

SECTION THREE - NORMAL OPERATION & PERIODIC MAINTENANCE

GENERAL

Each unit on a job will have its own unique operating environment and conditions that may dictate a maintenance schedule for that unit that is different from other equipment on the job. A formal schedule of regular maintenance and an individual unit log should be established and maintained. This will help to achieve the maximum performance and service life of each unit on the job.



Information regarding safety precautions contained in the preface at the beginning of this manual should be followed during any service and maintenance operations.

For more detailed information concerning service operations, consult your Sales Representative or the Factory.

MOTOR/BLOWER ASSEMBLY

The type of fan operation is determined by the control components and their method of wiring, and may vary from unit to unit. Refer to the wiring diagram for each unit for that unit's individual operating characteristics. Motors are permanently lubricated, PSC or EC type and do not require field lubrication.



Figure 5a

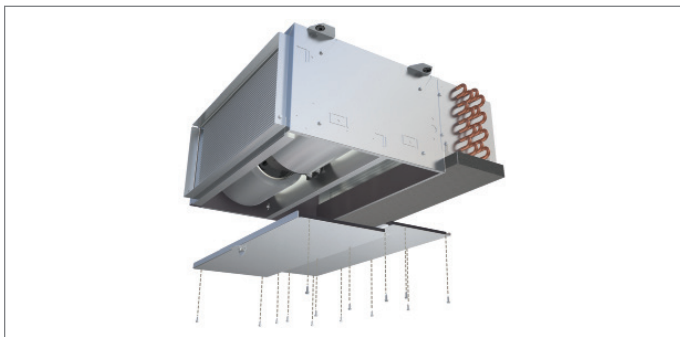

Figure 5b

Figure 5a-5b: Bottom panel removal

FAN DECK

The fan assembly is easily removed from the unit without disconnecting the ductwork for service access to motors and blowers at, or away from the unit.

Should the assembly require more extensive service, the motor/ blower assembly may be removed from the unit to facilitate such operations as motor or blower wheel/housing replacement, etc. Dirt and dust should not be allowed to accumulate on the blower wheel or housing. This can result in an unbalanced blower wheel condition that can damage a blower wheel or motor. The wheel and housing may be cleaned periodically using a vacuum cleaner and a brush taking care not to dislodge the factory balancing weights on the blower wheel blades.

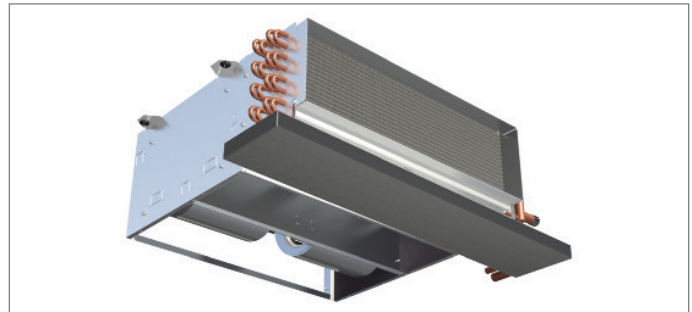

Figure 6a

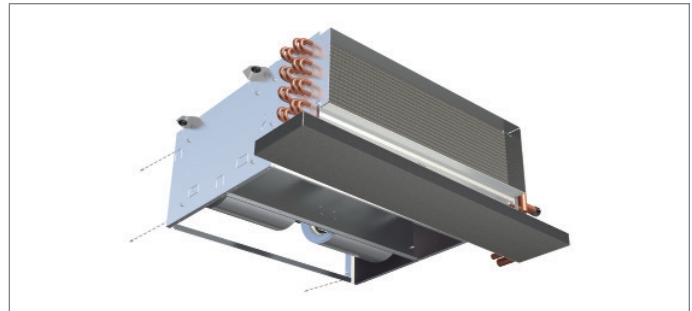

Figure 6b

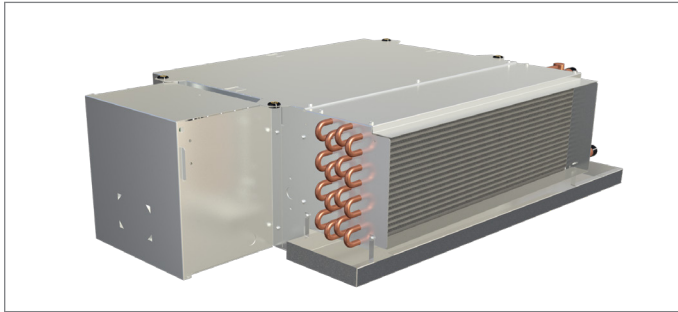

Figure 6c

Figure 6a-6c: Fan deck removal

COIL

Coils may be cleaned in place by removing the motor/ blower assemblies and brushing the entering air face between fins with a soft brush parallel to fins. Do not brush perpendicular to fin orientation as damage may occur. Brushing should be followed by cleaning with a vacuum cleaner. If a compressed air source is available, the coil may also be cleaned by blowing air through the coil fins from the leaving air face. Vacuuming should again follow this. Units provided with the proper type of air filters, replaced regularly, may require periodic coil cleaning.



ELECTRIC RESISTANCE HEATER ASSEMBLY

Electric resistance heaters typically require no normal periodic maintenance when unit air filters are changed properly. Other conditions and equipment may affect the operation and service life in the system. The two most important operating conditions for an electric heater are proper airflow and proper supply voltage. High supply voltage and/or poorly distributed or insufficient airflow over the element will result in element overheating. This condition may result in the heater cycling on the high limit thermal cutout. Open wire type heaters provided have an automatic reset switch with a back-up high limit thermal switch. Automatic reset switches are as the name implies; they reset automatically after the heater has cooled down. The high limit thermal cutout device is a manual reset safety device. With proper unit application and during normal operation, the high limit thermal cutout will not operate. This device only operates when some problem exists. ANY condition that causes high limit cutout MUST be corrected immediately. Once the high limit trips, it may be reset once the unit has cooled down. Refer to troubleshooting section for high limit reset instructions. High supply voltage also causes excessive amperage draw and may result in tripping of the circuit breaker or blowing of the fuses on the incoming power supply.

ELECTRICAL WIRING & CONTROLS

The electrical operation of each unit is determined by the components and wiring of the unit and may vary from unit to unit. Consult the wiring diagram for the actual type and number of controls provided on each unit. The integrity of all electrical connections should be verified at least twice during the first year of operation. Afterwards, all controls should be inspected regularly for proper operation. Some components may experience erratic operation or failure due to age. Wall thermostats may also become clogged with dust and lint and should be periodically inspected and cleaned to provide reliable operation.

When replacing any components such as fuses, contactors, or relays, use only the exact type, size, and voltage component as furnished from the factory. Any deviation without factory authorization could result in personnel injury or damage to the unit and will void all factory warranties. All repair work should be done in such a manner as to maintain the equipment in compliance with governing codes and ordinances or testing agency listings.

More specific information regarding the use and operating characteristics of the standard controls offered by this manufacturer is contained in other manuals.

VALVES & PIPING

No formal maintenance is required on the valve package components most commonly used with fan coil units other than a visual inspection for possible leaks in the course of other normal periodic maintenance. In the event that a valve should need replacement, the same precautions taken during the initial installation to protect the valve package from excessive heat should also be used during replacement. If a strainer is ordered with the unit the strainer must be cleaned periodically along with other scheduled maintenance. In some cases, the valve actuator may fail and usually can be replaced without removing valve body from piping.

DRAIN

The drain should be checked before initial start-up and at the beginning of each cooling season to assure that the lines are clear. If it is clogged, steps should be taken to clear the debris so that condensate will flow easily.

Periodic checks of the drain should be made during the cooling season to maintain a free flowing condensate. Should the growth of algae and/or bacteria be a concern, consult an air conditioning and refrigeration supply organization familiar with local conditions for chemicals available to control these agents. If cleaners are used, they should be compatible with the materials of construction for the coil, drain pan, and condensate pump (if applicable).

FILTERS, THROWAWAY

The type of throwaway filter most commonly used on fan coil units should be replaced on a regular basis. The time interval between each replacement should be established based on regular inspection of the filter and should be recorded in the log for each unit. Refer to the chart on page 20 for recommended filter size for each product type and size. If the replacement filters are not purchased from the factory, the filters used should be the same type and size as that furnished from or recommended by the factory. Consult the factory for applications using filter types other than the factory standard or optional product.

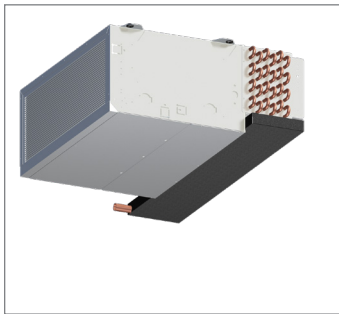

Figure 7a - Filter Removal

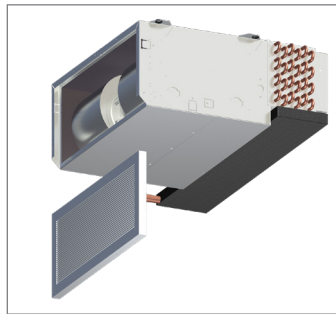

Figure 7b - Filter Removal

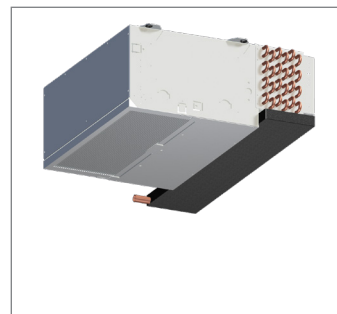

Figure 7c - Filter Removal

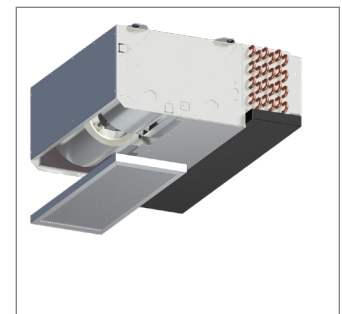

Figure 7d - Filter Removal

TABLE 4: FACE AREA, FREE AREA AND FILTER SIZES

UNIT SIZE	COIL FACE AREA	RETURN AIR GRILLE FREE AREA	SUPPLY AIR GRILLE FREE AREA	FILTER FACE AREA (REAR RETURN)	NOMINAL FILTER SIZES (REAR RETURN)	FILTER FACE AREA (BOTTOM RETURN)	NOMINAL FILTER SIZES (BOTTOM RETURN)
02	0.89 [0.08]	0.83 [0.08]	0.61 [0.06]	1.17 [0.11]	"16 x 10.5 x 1 [406 x 267 x 25]"	1.06 [0.1]	"16 x 9.5 x 1 [406 x 241 x 25]"
03	1.07 [0.1]	0.83 [0.08]	0.61 [0.06]	1.39 [0.13]	"19 x 10.5 x 1 [483 x 267 x 25]"	1.25 [0.12]	"19 x 9.5 x 1 [483 x 241 x 25]"
04	1.35 [0.13]	1.25 [0.12]	0.92 [0.09]	1.77 [0.16]	"24.25 x 10.5 x 1 [616 x 267 x 25]"	1.60 [0.15]	"24.25 x 9.5 x 1 [616 x 241 x 25]"
06	1.72 [0.16]	1.45 [0.14]	1.07 [0.1]	2.26 [0.21]	"31 x 10.5 x 1 [787 x 267 x 25]"	2.05 [0.19]	"31 x 9.5 x 1 [787 x 241 x 25]"
08	2.11 [0.2]	1.87 [0.17]	1.38 [0.13]	2.77 [0.26]	"(2) 19 x 10.5 x 1 [483 x 267 x 25]"	2.51 [0.23]	"(2) 19 x 9.5 x 1 [483 x 241 x 25]"
09	2.35 [0.22]	2.08 [0.19]	1.53 [0.14]	3.08 [0.29]	"(1) 20, (1) 22.25 x 10.5 x 1 [508, 565 x 267 x 25]"	2.79 [0.26]	"(1) 20, (1) 22.25 x 9.5 x 1 [508, 565 x 241 x 25]"
10	2.89 [0.27]	2.7 [0.25]	1.99 [0.18]	3.79 [0.35]	"(2) 26 x 10.5 x 1 [660 x 267 x 25]"	3.43 [0.32]	"(2) 26 x 9.5 x 1 [660 x 241 x 25]"
12	3.33 [0.31]	3.12 [0.29]	2.3 [0.21]	4.38 [0.41]	"(1) 20, (1) 40 x 10.5 x 1 [508, 1016 x 267 x 25]"	3.96 [0.37]	"(1) 20, (1) 40 x 9.5 x 1 [508, 1016 x 241 x 25]"

NOTES:

1. Face and free areas are in square feet [square meters].
2. Filter sizes are in inches [millimeters].
3. Free area of Krueger® Model KHFE and Telescoping Bottom Panel return grilles.
4. Free area of Krueger® Model KHFE supply grille and minimum free area allowable for a supply grille supplied by others.

CONDENSATE WATER PUMP



SAFETY WARNING: Risk of electric shock. Make certain that the entire power supply to the unit/system is disconnected before attempting to install, service or remove this component.

General Information

The high performance water condensate pump is suitable for units up to 5.6 tons (67 kBtu - 20 kW). The piston technology is specifically designed for removing condensate from air conditioning systems. It is fully reliable, in any kind of environment and its operating sound level will remain silent <23 dB whatever the volume of condensate.

The condensate pump uses a temperature differential between two measurements to determine if it runs. If there is greater than 14°F between the measurements, the pump runs. The cold sensor is placed on the chilled water supply and the warm sensor is placed in the fan compartment. The pump is capable of running without any water. Discharge tubing is not factory provided and must be field provided during the initial installation process.

TECHNICAL SPECIFICATIONS	
OPERATION VOLTAGE	120V +/- 10% -50/60Hz - 4.7W 208 - 230V +/- 10% -50/60Hz - 4.7W
OPERATING TEMPERATURE	Max 257 °F (125 °C) auto-reset
THERMAL PROTECTION (OVERHEATING)	257 °F (125 °C) auto-reset
MAX HEAD	23 Ft
MAX SUCTION LIFT	16.52 Ft
TUBING (NOT INCLUDED)	Flexible tubing 1/4" ID, 3/8" OD

Replacement Instructions

- Disconnect the main power on the unit.
- For wiring connection to unit, refer to unit wire diagram.
- For accessories, assembly, and internal wire connections, refer to condensate water pump manufacturer instructions.
- Locate the two alignment holes for the water pump bracket, right bottom corner of the unit.
- Attach pump to bracket and mount it to unit with two screws. (See Figure 1)
- Complete all assembly prior to mounting pump cover.
- Connect flexible tubing (not supplied). Once all of the connections are made, reconnect the main power of the unit.

CURRENT SWITCH DEVICE



SAFETY WARNING: The Current Switch is intended to provide an input to equipment under normal operating conditions. Where failure or malfunction of the Current Switch could lead to personal injury or property damage to the controlled equipment or other property, additional precautions must be designed into the control system. Incorporate and maintain other devices, such as supervisory or alarm systems or safety or limit controls, intended to warn of or protect against failure or malfunction of the Current Switch.

General Information

The Current Switch is a non-intrusive device that detects current flowing through the motor power wire. Completely self-powered, the Current Switch draws its power from current induced by the power wire of the motor being monitored. Fig. 5 shows the current switch wire connections. It is panel mounted with two screws inside the main electrical enclosure; refer to fig. 6.

TECHNICAL SPECIFICATIONS	
WIRE SIZE	2.1-0.6 mm (12-22 AWG) diameter recommended
STATUS OUTPUT	Switch normally open
SWITCH LOAD CAPACITY	1 A at 30 VAC/42 VDC maximum

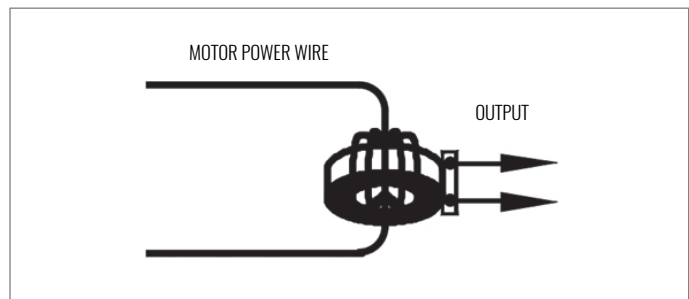

Figure 9 Current Switch in Circuit

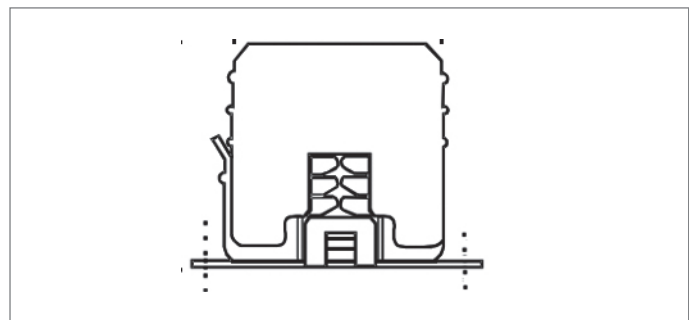

Figure 10 Current Switch Mounting

DIFFERENTIAL AIR PRESSURE SWITCH

General Information

This accessory is a differential pressure switch with a normally-open (NO) dry contact that is factory calibrated to close at a differential pressure of 0.15 inches of water or greater. The switch measures the pressure differential between the unit's fan section and the environmental pressure outside the unit. When the filter is sufficiently clogged or dirty, differential pressure will rise and the switch will close.

General Measurements: Pressure Switch

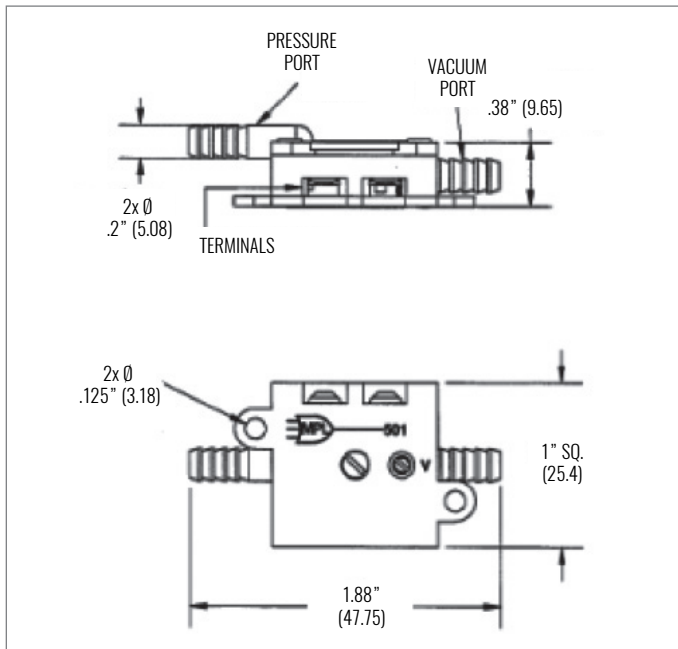

Figure 11

Assembly

The differential air pressure switch is mounted inside the unit with double sided tape behind the filter retention tab. (See figure 12a). Instructions for commissioning or replacing the differential air pressure switch:

- Disconnect main power on the unit.
- Secure differential air pressure switch on the filter retention tab using double sided tape. Position the pressure port (marked with "+") outside the chassis exposed to the environment. The vacuum port should extend inside the chassis and be open to the unit's fan section. (See figure 12b.)
- Wire the NO relay using .187 quick connectors.
- Verify all connections before reconnecting main power.

ELECTRICAL TECHNICAL SPECIFICATIONS

INITIAL RESISTANCE	<500mW
--------------------	--------

RATING	3.15ma @ 125VAC 10-20ma @ 5-24VDC
--------	--------------------------------------

ADJUSTABLE SET POINT RANGES IN H₂O

Ranges In H ₂ O	Min.	Max.	Proof
	0.10	0.50	5.0

FUNCTIONAL TECHNICAL SPECIFICATIONS

Operating positing	Diaphragm vertical, barbed fittings horizontal
--------------------	--

Operating temp.	-40 °F to 140 °F (-40 °C to 60 °C)
-----------------	------------------------------------

DISCHARGE AIR SENSOR

General Information

The Discharge Air Sensor is a nickel 1kΩ sensor probe with a flanged mounting bracket (no enclosure).

Suggested Location

The Discharge Air Sensor is fitted to the side of the coil flange in the holes provided for this accessory. (See Figure 13.)

Replacement Instructions

- Disconnect the main power on the unit.
- Mount the Discharge Air Sensor with two screws as shown. (See Figure 13.)
- Secure the plenum-rated cable into control enclosure using the control enclosure knockouts accordingly.
- Once all of the connections are made, reconnect the main power.

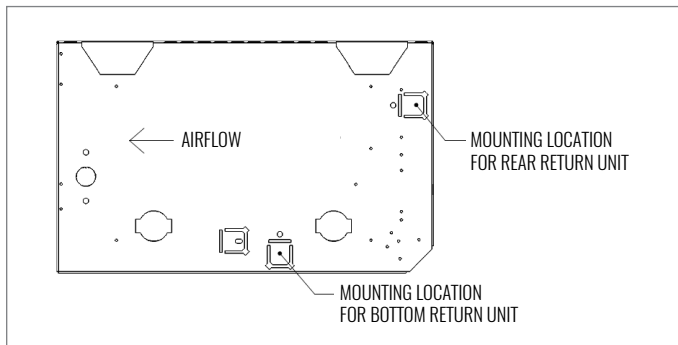

Figure 12a

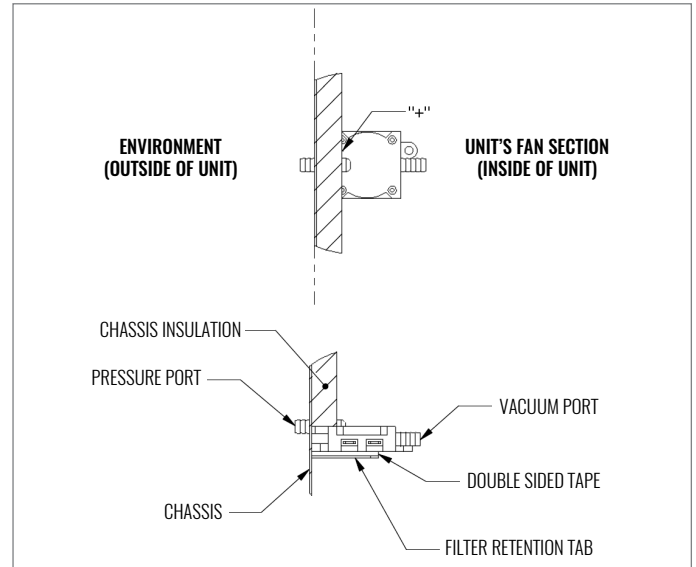

Figure 12b

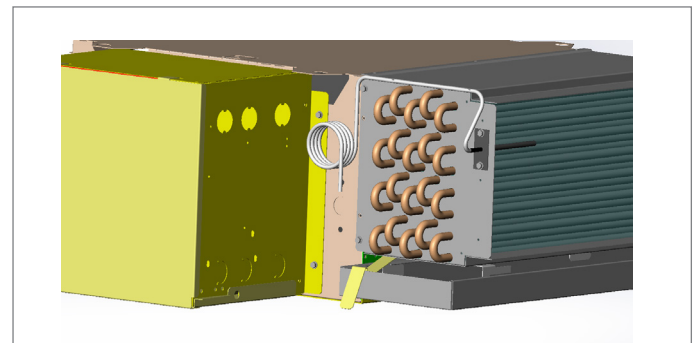

Figure 13

LOW TEMPERATURE CUTOUT CONTROL

General Information

This low temperature device will de-energize the system if the operating conditions begin to approach freezing (as water freezes it expands and will rupture the coil barrel tubes). The function of this low temperature device is to cycle a SPST switch in response to changes of temperature. Refer to fig. 4 to locate the device on your unit.

Adaptable Cold Control

Range of adjustments are limited to the rotation of the dial for the required temperature set point needed.

ALTITUDE CORRECTIONS			
FEET	TURNS	FEET	TURNS
2000	35	8000	215
4000	100	9000	250
6000	160	10000	270

NOTE: Clockwise turns of range screw.

Electrical Ratings



WARNING: Do not exceed the maximum wattage, ratings, or published operating conditions as noted below.

Replacement Instructions

The primary purpose of the low limit cutout is to prevent the coil from freezing. Therefore, before mounting the control, you need to consider all possible factors that help protect the coil from freezing. It is important that the cutout capillary not be cut, kinked or pinched in mounting to unit elements. Also, ensure tubing clamps and wells are of compatible material with the control sensing element to prevent corrosion.

- Disconnect the main power on the unit.
- Locate the two inner mounting holes between control enclosure and coil.
- Use two supplied screws to mount the low temperature cutout in place.
- Work your way back up to the bellows, stringing the sensing element throughout the drain pan,
- Position the sensing element horizontally across the face of the coil, and secure the sensing element with mount tape and wire tie. (See Figure 14.)
- Wire the NC relay using the .250 quick connectors.
- Once all of the connections are made, reconnect the main power of the unit.

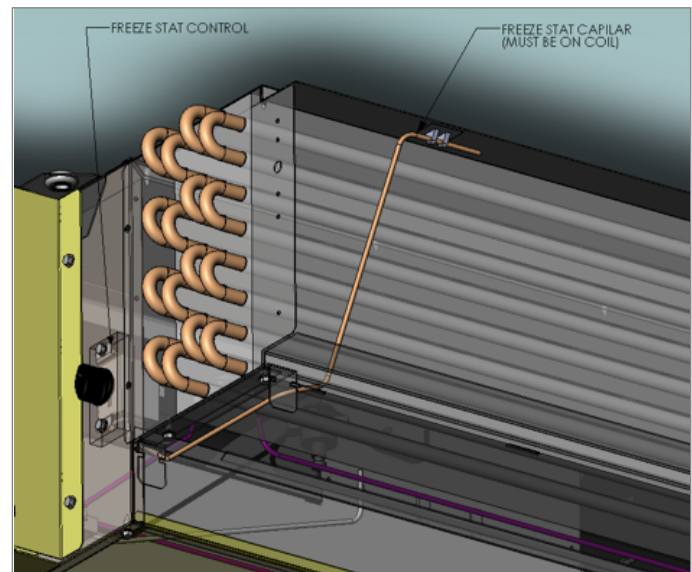

Figure 14

CONDENSATE FLOAT SWITCH INSTALLATION

Ensure float switch assembly is firmly secured to the bracket. Ensure top of float is below rim of pan. Switch will trip when the water level reaches a point even with top of float when float is in down position. Sensitivity may be adjusted by threading switch assembly downward out of bracket if necessary.

Test switch by lifting float with unit on. Unit should stop running if switch is correctly wired. Test switch sensitivity by filling pan and confirm switch stops unit before pan overflows.

Supplier's Install Instructions

1. Disconnect power to unit at main panel.
2. Clip switch bracket onto side of pan at low end and press firmly into place ensuring switch wires are positioned up ensure float moves freely.
3. Secure bracket into side of pan using self-tapping sheet metal screw through upper hole in bracket.
4. Ensure float switch assembly is firmly secured to bracket. Ensure top of float is below rim of pan. Switch will trip when water level reaches a point even with top of float (when float is in down position). Sensitivity may be adjusted by threading switch assembly downward out of bracket if necessary.
5. Ensure wiring matches the wiring diagram provided with the unit.
6. Test switch by lifting float with unit on. Unit should stop running if switch is correctly wired.
7. Test switch sensitivity. Fill pan and confirm that switch stops unit before pan overflows.
8. Place warning sticker on air handler or condenser unit.

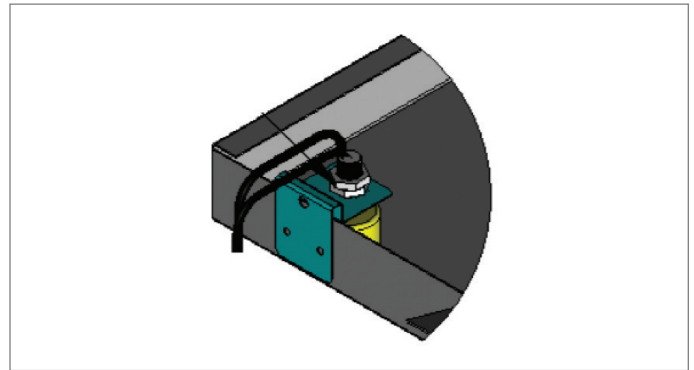

Figure 15a: Drain pan float switch installed

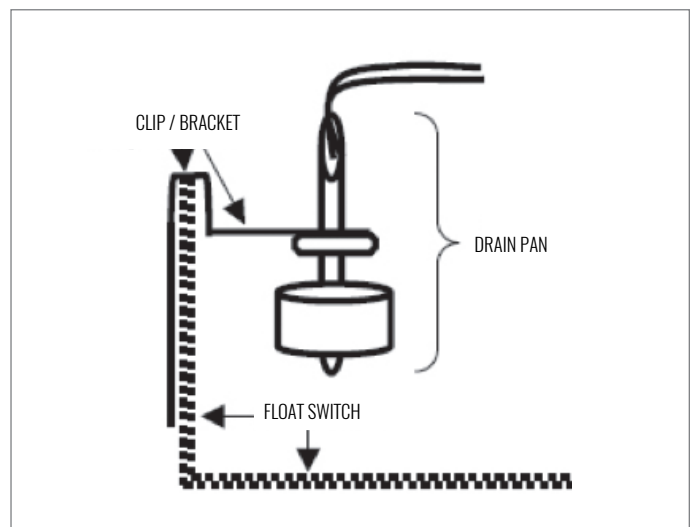

Figure 15b: Drain pan float switch diagram

REPLACEMENT PARTS

Factory replacement parts should be used wherever possible to maintain the unit performance and operating characteristics and the testing agency listings. Replacement parts may be purchased through the local Sales Representative.

Contact the local Sales Representative before attempting any unit modifications. Any modifications not authorized by the factory could result in personnel injury and damage to the unit and could void all factory warranties and regulatory listings.

When ordering parts, the following information must be supplied to ensure proper part identification:

1. Complete unit model number
2. Unit hand connection (right or left hand) while facing the direction of airflow at the inlet
3. Complete part description including any numbers.

On warranty replacements, in addition to the information previously listed, the project CO # that appears on the unit nameplate, is required. Contact local Sales Representative and refer to warranty policy.

All equipment and components sold through the Parts Department are warranted under the same conditions as the standard manufacturer's warranty with the exception that the warranty period is 12 months.

UNIT WEIGHTS

TABLE 5: UNIT WEIGHT DATA (LBS./KG)									
COMPONENT	UNIT SIZE								
	02	03	04	06	08	09	10	12	
KHFH BASE UNIT	22 [10]	25 [12]	33 [15]	43 [20]	53 [24]	60 [27]	74 [34]	83 [38]	
KHFH BASE UNIT	24 [11]	28 [13]	36 [16]	47 [21]	58 [26]	65 [30]	81 [37]	91 [41]	
KHFH BASE UNIT	56 [25]	63 [29]	75 [34]	92 [42]	108 [49]	118 [54]	141 [64]	158 [72]	
COIL ROWS	1 ROW - DRY	6 [3]	7 [3]	8 [4]	10 [4]	11 [5]	13 [6]	15 [7]	17 [8]
	1 ROW - WET	8 [4]	9 [4]	10 [4]	12 [5]	13 [6]	15 [7]	17 [8]	19 [9]
	2 ROW - DRY	7 [3]	8 [4]	10 [4]	12 [5]	14 [6]	16 [7]	19 [9]	22 [10]
	2 ROW - WET	9 [4]	10 [5]	12 [5]	14 [6]	17 [8]	19 [8]	23 [10]	27 [12]
	3 ROW - DRY	8 [4]	10 [4]	12 [5]	14 [6]	17 [8]	19 [9]	23 [10]	26 [12]
	3 ROW - WET	10 [5]	12 [5]	15 [7]	17 [8]	21 [10]	23 [10]	28 [13]	32 [14]
	4 ROW - DRY	9 [4]	11 [5]	13 [6]	17 [8]	20 [9]	22 [10]	27 [12]	30 [14]
	4 ROW - WET	13 [6]	15 [7]	18 [8]	22 [10]	26 [12]	28 [13]	34 [15]	38 [17]
	5 ROW - DRY	11 [5]	13 [6]	15 [7]	19 [9]	23 [10]	25 [11]	30 [14]	35 [16]
	5 ROW - WET	17 [8]	19 [8]	22 [10]	26 [12]	31 [14]	33 [15]	39 [18]	45 [20]
	6 ROW - DRY	12 [5]	14 [6]	17 [8]	21 [10]	26 [12]	28 [13]	34 [16]	39 [18]
	6 ROW - WET	19 [9]	21 [10]	25 [11]	29 [13]	36 [16]	38 [17]	45 [21]	51 [23]

SECTION FOUR: INSPECTION & START-UP CHECKLIST

RECEIVING & INSPECTION

- Unit received undamaged
- Unit received complete as ordered
- Unit arrangement/hand correct
- Unit structural support complete & correct

HANDLING & INSTALLATION

- Unit mounted level & square
- Proper access provided for unit & accessories
- Proper electrical service provided
- Proper overcurrent protection provided
- Proper service switch/disconnect provided
- Proper hot water line to unit
- Proper chilled water line size to unit
- Proper steam line sizes to unit
- Proper refrigerant line sizes to unit
- Proper steam supply pressure to unit (15psi max)
- Proper steam condensate trap on return line
- All shipping screws & braces removed
- All services to unit in code compliance

COOLING/HEATING CONNECTIONS

- Protect Valve Package Components From Heat
- Mount valve packages
- Connect Field Piping To Unit
- Pressure test all piping for leaks
- Install Drain Line & Traps As Required
- Insulate all piping as required
- Install Condensate Pan under Piping as Required

DUCTWORK CONNECTIONS

- Install Ductwork, Fittings & Grilles As Required
- Proper supply & return grille type & size used
- Control Outside Air For Freeze Protection
- Insulate all ductwork as required

ELECTRICAL CONNECTIONS

- Refer to unit wiring diagram
- All field wiring in code compliance
- Connect incoming power service or services

UNIT STARTUP

- General visual unit & system inspection
- Record electrical supply voltage
- Record ambient temperature
- Check all wiring for secure connections
- Close all unit isolation valves
- Flush water systems
- Fill systems with water/refrigerant
- Vent water systems as required
- All ductwork & grilles in place
- All unit panels & filters in place
- Start fans, etc.
- Check for overload condition of all units
- Check all ductwork & units for air leaks
- Balance air systems as required
- Record all final settings for future use
- Check piping & ductwork for vibration
- Check all dampers for proper operation
- Verify proper cooling operation
- Verify proper heating operation
- Reinstall all covers & access panels

SECTION FIVE: FAN RELAY BOARD

INSTALLATION, OPERATION AND MAINTENANCE

The Fan Relay Board assembly (FRBii) provides electronic control for the fan motor and various connections for peripheral devices. The FRBii accepts incoming single phase power of nominal AC voltages 120, 208, 240 and 277. The assembly includes a multitap transformer (30VA or 50VA) that steps each of these primary voltages to 24 VAC. The assembly allows for the control of a three speed fan motor, including a relay for control of the neutral voltage signal path.

The FRBii can be connected to an external device (e.g., thermostat, controller, 3-speed switch) to control the three fan speeds. The FRBii includes logic to detect when multiple speeds are commanded simultaneously and block all but the highest of the commanded speeds from being sent to the motor windings. A signal to call for electric heat from an external controller will verify that a fan speed is selected before providing the command signal to the external electric heat control to ensure that electric heat can only be energized when the fan motor is operational. The assembly includes factory provided harnesses to allow for faster installation and improved troubleshooting by the end user.

The FRBii allows for peripheral devices (e.g., thermostat controllers, electric heat relays, water valve actuators, condensate drain pan float switches, air dampers) to be connected by either the OEM or by the installer. The fan relay board also includes a fuse on the secondary side of the transformer to protect against incorrect wiring of external components, shorting the transformer leads. The signals in the screw terminal block (TB1) and 18-pin black connector (J1) have a nominal voltage of 24VAC. These signals are properly insulated from line voltage present on the assembly (J2-J5) transformer to protect against incorrect wiring of external components, shorting the transformer leads.

The signals in the screw terminal block (TB1) and 18-pin black connector (J1) have a nominal voltage of 24VAC. These signals are properly insulated from line voltage present on the assembly (J2-J5).

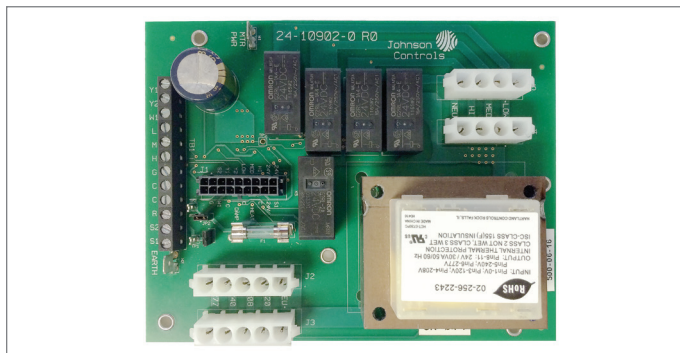

Figure F.1: Fan Relay Board (FRBii)

INSTALLATION

MOUNTING

Important: Do not overtighten the screws. Overtightening may strip the threads and will void the warranty.

Using #8-3/4" screws (quantity six), install the assembly using the provided standoffs.



Risk of Electric Shock: Disconnect or isolate all power supplies before making electrical connections. More than one disconnection or isolation may be required to completely de-energize equipment. Contact with components carrying hazardous voltage can cause electric shock and may result in severe personal injury or death.

WIRING

Install the wiring so it does not cause a hazard, and is protected against electrical and mechanical damage.



Risk of Electric Shock: Ground the FRBii according to local, national, and regional regulations. Failure to ground the FRBii may result in electric shock and severe personal injury or death.

Ground the assembly from the EARTH terminal (W2) to the enclosure.

Ratings

MODEL(S)	30VA – PC-01-0134 PK-FCU030-0 (25-3043-7)
	50VA – PC-01-0135 PK-FCU050-0 (25-3043-15)
VOLTAGE	120 through 277VAC
CURRENT (FAN RELAYS)	12A
OPERATING TEMPERATURE	-4°F to 140°F (-20°C to 60°C)

Reference Wire Diagram

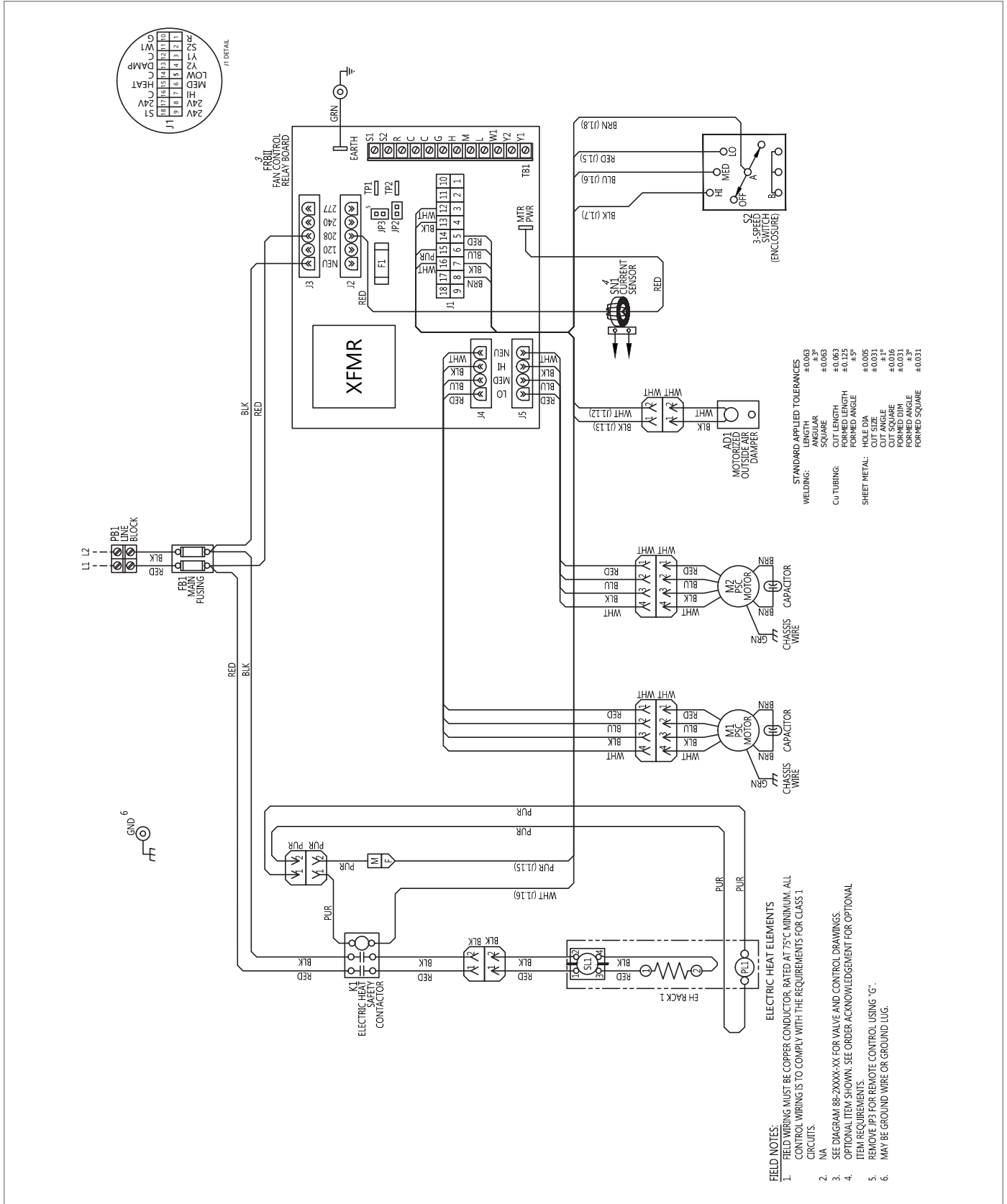

FRBii INPUTS AND OUTPUTS

TB1 – Low Voltage Peripheral Devices

(See Table F.9 for detailed description of each signal)

TABLE F.1 – SCREW TERMINAL (TB1) SIGNAL IDENTIFICATION	
PIN	SIGNAL
1	Y1 – Cool 1
2	Y2 – Cool 2
3	W1 – Heat 1
4	L – Low
5	M – Medium
6	H – High
7	G – Fan Enable
8	C – Common (through JP2)
9	C – Common (through JP2)
10	R – 24VAC
11	S2 – Auxiliary Input (Heat 2)
12	S1 – Common

J1 – Low Voltage Peripheral Devices

TABLE F.2 – LOW VOLTAGE PERIPHERAL DEVICE (J1) SIGNAL IDENTIFICATION	
PIN	SIGNAL
1	R – 24VAC
2	S2 – Aux In (Heat 2)
3	Y1 – Cool 1
4	Y2 – Cool 2
5	LOW
6	MED
7	HIGH
8	24V
9	24V
10	G – Fan Enable
11	W1 – Heat 1
12	COM
13	DAMP – Damper
14	COM
15	HEAT – Heat output
16	COM
17	24V
18	S1 – Common

J2/J3 – Incoming Power

TABLE F.3 – INCOMING POWER (J2 & J3) SIGNAL IDENTIFICATION	
PIN	SIGNAL
1	NEUT
2	120
3	208
4	240
5	277

J4/J5 – Motor Output

TABLE F.4 – MOTOR OUTPUT (J4 & J5) SIGNAL IDENTIFICATION	
PIN	SIGNAL
1	LOW
2	MED
3	HIGH
4	NEUT

W1 – MTR PWR

The MTR PWR quick connect provides voltage to the line side of the fan speed relays through an external jumper. For PSC motors, this will be the line voltage of the unit. For EC motors, this will either be 24VAC (without PWM) or a switch contact common (with PWM).

W2 – EARTH

EARTH connection grounds the secondary side of the transformer to the enclosure cabinet through a wire bonded to the control enclosure.

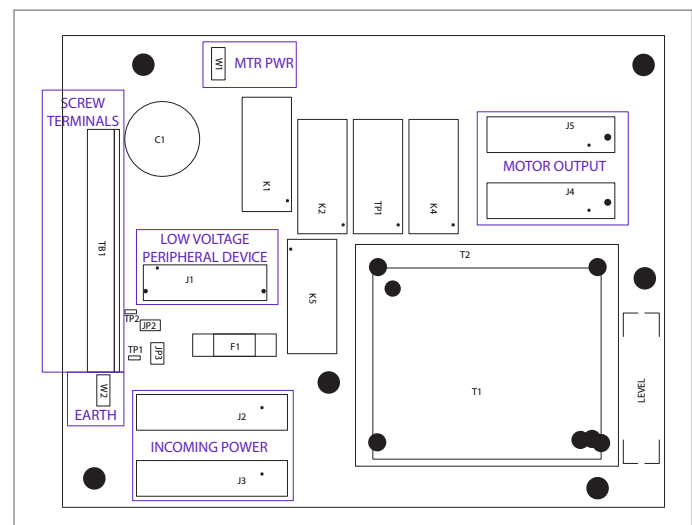

Figure F.2 – Connector layout

Tools Required for Installation/Troubleshooting:

- Digital multimeter capable of measuring 30 volts AC
- Insulated 1/8" flat bladed screwdriver
- Fuse puller (optional)
- Mini hook test clips for multimeter (optional)

Fuse - A fuse is included on the secondary side of the transformer to protect the transformer from incorrect wiring of thermostat, controller, etc. that shorts the 24VAC and COM. The fuse is a fast-acting glass body cylindrical fuse (5x20mm). If tripped, replace the fuse by removing the tripped fuse with fuse pullers and replace using one of the below listed fuses.

Suggested fuse replacement information:

TABLE F.5 – REPLACEMENT FUSE				
TRANSFORMER	FUSE	PART NUMBER	MANUFACTURER	PART NUMBER
30VA	2A	PE-06-0000	Littelfuse	0235002.MXP
			Bussmann	BK/GMA-2-R
50VA	3A	PE-06-0016	Littelfuse	0235003.MXP
			Bussmann	BK/GMA-3-R

HEAT Output – The HEAT output connects to an electric heat contactor or relay. This output represents the command signal from the thermostat or controller on the W1 input. The output is interlocked with the fan relays to ensure that a fan speed is commanded when electric heat is requested.

DAMP Output – The DAMP output connects to a motorized damper actuator used to control airflow from an external source. This output provides 24VAC to energize the damper actuator. This output is interlocked with the fan relays to ensure that a fan speed is commanded before energizing the damper actuator.

TABLE F.6 – FIELD INSTALLED COMPONENT DESCRIPTIONS	
NAME	DESCRIPTION
Field-Provided Float Switch	To install a float switch, wire the float switch leads into S1 and C on the crew terminals. After wiring the float switch, remove jumper JP2. The JP2 jumper must be removed for the float switch to operate correctly. Note: If a float switch was installed in the factory, the float switch may be connected through a factory-provided harnesses instead of wired to the screw terminal.
Start/Stop for the Fan	To start or stop the fan from an external controller, wire the leads for the switch contacts that will be made or broken to R and G on the screw terminals. After wiring the switch, remove jumper JP3.
Remote 3-Speed Switch	To add a remote 3-speed switch, wire the leads for the switch to G, H, M and L on the screw terminals. After wiring the switch, remove jumper JP1.

JUMPERS

TABLE F.7 – JUMPER DESCRIPTION		
JUMPER	NAME	DESCRIPTION
JP1	Speed Select Jumper	This jumper is installed between 24V and HIGH when no three speed switch is included (remote or unit mounted). The jumper will be installed at the end of the harness connected to J1. If a three speed switch is added later, JP1 must be removed.
JP2	Float Switch Jumper	This jumper is installed between S1 and C when a float switch is not installed. The jumper is removed when a float switch is installed.
JP3	Fan Enable Jumper	This jumper is installed between R and G/24V. The jumper is removed when remote control of the fan motor is desired. In most instances, JP3 will be installed (unless a thermostat or controller is remotely controlling of the equipment).

JP2 and JP3 locations can be seen in Figure F.3.

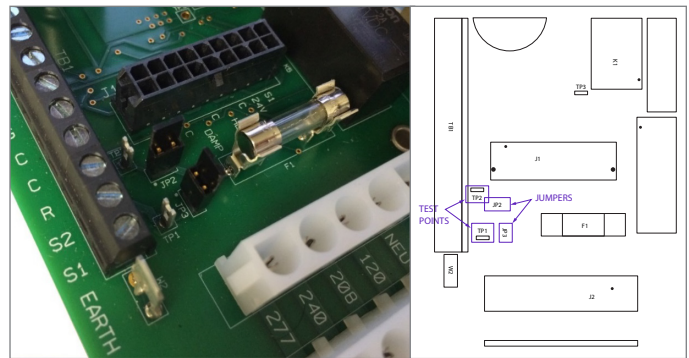

Figure F.3: FRBii Jumpers and Test Points

TEST POINTS

TABLE F.8 – TEST POINT DESCRIPTION		
TEST POINT	NAME	DESCRIPTION
TP1	24VAC	These test points can be used to verify 24 VAC assuming incoming voltage is within tolerance. They can be connected to with mini-hook test clips for a digital multimeter. Test point locations for TP1 and TP2 can be seen in Figure F.3.
TP2	COM	

SCREW TERMINAL SIGNALS

TABLE F.9 – SCREW TERMINAL SIGNAL IDENTIFICATION			
PIN	SIGNAL	SIGNAL NAME	DESCRIPTION
1	Y1	Cool 1	Chilled water valve actuator control input and thermostat cooling output.
2	Y2	Cool 2	“Close” input of modulating chilled water valve actuator or 2nd stage chilled water valve actuator control input and thermostat cooling output. Y1 is “Open” output if floating (tristate) chilled water valve actuator is installed.
3	W1	Heat 1	Wire connection point for hot water valve actuator or 1st stage EH control input, and thermostat heating output.
4	L	Low	Low speed control input for onboard relay.
5	M	Medium	Medium speed control for onboard relay.
6	H	High	High speed control input for onboard relay.
7	G	Fan Enable	Used to allow external start-stop control from an external source.
8	C	Common (through JP2)	Device common, including onboard speed relays (all terminals C and “COM” on board are internally connected).
9	C		
10	R	24VAC	Transformer “hot” connection (24VAC).
11	S2	Auxiliary Input (Heat 2)	Used for different functions based on application, such as: • 2 nd stage heat control for two stage EH applications • Changeover water valve/aquastat for two pipe changeover applications. • “Close” input of modulating hot water valve actuator and “Close” output of thermostat in floating [tristate] water valve applications.
12	S1	Common	Common side of transformer. Jumped to C (common) through JP2. If application calls for float switch JP2 is removed and float switch is connected between S1 and C.

CHECKING WIRE HARNESES

Use ohm meter to verify that ground wire has continuity from S1 to enclosure case.

To Check Incoming Power Wire Harness:

- Refer to wiring diagram.
- Remove power from the unit. Unplug power harness J2 or J3 connector.
- Unplug power wires from connections (line block, disconnect switch, toggle switch or fuse(s)) in electrical enclosure. Verify continuity of wires, then reconnect to J2 or J3 connector.

To Check Motor Harness:

- Refer to wiring diagram.
- Remove power from the unit. Unplug motor harness J4 and/or J5 connector.
- Unplug motor harness from motor connection or PWM board (depending on type of motor). Verify continuity of wires, then reconnect to J4 or J5 connector and to motor or PWM board.

To Check Low Voltage Wire Harnesses:

- Remove power from the unit. Unplug low voltage harness J1 connector and disconnect connections at other end of J1 harness.
- Use ohmmeter to check continuity for each conductor, then reconnect harness to J1 connector and to other connections.

Before reconnecting power to unit, verify all harnesses are connected per diagram.

Use caution when inserting meter probe into plug. Excess force will damage contacts.

SECTION SIX: TROUBLESHOOTING



Risk of Electric Shock: Disconnect or isolate all power supplies before making electrical connections. More than one disconnection or isolation may be required to completely de-energize equipment. Contact with components carrying hazardous voltage can cause electric shock and may result in severe personal injury or death.

No routine maintenance is required for the fan relay board.

TABLE F.10 - FAN RELAY BOARD		
PROBLEM	POSSIBLE CAUSE	CORRECTIVE ACTION
NO 24VAC POWER	Blown fuse onboard (F1)	Measure resistance across fuse: <ul style="list-style-type: none"> • A properly working fuse will measure <math><1.0\Omega</math>. • A blown fuse will measure as an open circuit. Replace fuse if blown using replacement fuse identified above.
	Incorrect incoming line voltage	Verify incoming voltage to the unit is within tolerance.
	Improper wiring connections	<ul style="list-style-type: none"> • Verify that the unit is wired per the unit wiring diagram for incoming voltage. If the unit includes main fusing, verify that the fuses are not blown. • Verify wire harness connections are secure. See "Checking Wire Harnesses" section.
	JP2 removed without float switch installed	Verify that either a float switch or JP2 are installed. If neither, install one of them.
	Float switch tripped	Verify float switch (if present) is made.
	JP3 removed without external start/stop control installed	Verify that either an external start/stop or JP3 are installed. If neither, install one of them.
	Damaged transformer	If all of the above are confirmed, replace the fan relay board.
FAN MOTOR WILL NOT RUN	No 24VAC power	See above.
	Fan speed is not commanded	Verify a fan speed is commanded from either jumper JP1, a unit-mounted or remote-mounted three speed switch, or a thermostat.
ELECTRIC HEAT SIGNAL IS NOT PROVIDED TO CONTACTOR	Fan speed is not commanded	Verify that fan motor is running. A fan speed must be commanded from one of these sources to allow the electric heat contactor to energize on a call for heat.
OUTSIDE AIR DAMPER ACTUATOR WILL NOT ENERGIZE	Fan speed is not commanded	Verify that fan motor is running. A fan speed must be commanded from one of these sources to allow the damper actuator to energize.

TROUBLESHOOTING (CONTINUED)

PSC MOTOR		
PROBLEM	POSSIBLE CAUSE	CORRECTIVE ACTION
NO AIRFLOW [PSC MOTOR]	No demand	Verify thermostat or control is calling for heating or cooling.
	Fan speed is not commanded	Verify fan run command is present at 'g' terminal of fan relay board (24v units) or of terminal block.
	No power to motor; possible blown fuse or open circuit breaker	Verify line voltage at motor terminals. Replace fuse or reset circuit breaker.
	Incorrect voltage applied	Verify proper voltage to unit per unit label.
	Improper wiring connections	Verify wiring. If fan coil relay board present, verify all jumpers and harnesses installed. Refer to fan coil relay board troubleshooting guide.
	Fan speed adjustment outside operating range	If fan speed controller present, adjust fan speed control screw to full clockwise position. Verify that motor starts. Reduce adjustment.
	[24V units] three speed switch in off position	Verify three speed switch, if present, is set to desired speed.
	[24V units] loss of 24v power	Refer to fan relay board troubleshooting guide.
	[24V units] drain pan float switch tripped	If drain pan float switch installed. Verify drain pan is not full. Verify operation of float switch. Adjust switch position if needed.
	[24V units] drain pan float switch fault	Verify operation of float switch, if installed. Disconnect switch and use volt-ohm meter to verify continuity of switch and of wiring. Replace switch if faulty.
	Low temperature cutout has tripped	If low temperature cutout present. Examine coil for signs of freezing. Verify adjustment of freeze stat. Disconnect switch and use volt-ohm meter to verify continuity. Replace switch if faulty.
	Blower jammed	Remove power from unit. Clear blockage. Verify blower is not damaged and rotates freely while motor is not energized.
	Failed motor capacitor	If motor hums or buzzes but does not start. Disconnect power from unit. Discharge capacitor. Remove motor capacitor from circuit. Use analog volt-ohm meter to verify motor capacitor. Set meter to kilo-ohms scale. Touch probes to capacitor terminals. Needle will jump to zero ohms then drift back to high ohms. Steady high ohms or steady low ohms indicates failed capacitor.
	Motor seized	Remove power from unit. Verify motor rotates freely by hand with blower disconnected. If not, replace motor.
	Damaged motor harness	Replace motor harness.
Motor overloaded	Verify motor is not overheated. Check to ensure blower rotates freely with motor disconnected. Verify proper duct static. Wait for motor to cool down and verify motor start. If motor overheats again, replace motor.	
POOR AIRFLOW PERFORMANCE [PSC MOTOR]	Lack of required external static pressure	External static pressure not as designed. Adjust external static pressure to design pressure.
	[24V units] three speed switch in wrong position.	Verify three speed switch, if present, is set to desired speed.
	Poor voltage quality	Verify input voltage within acceptable parameters.
	Fan speed control adjustment outside fan operating range	If fan speed controller present. Adjust fan speed control screw to full clockwise position. Verify airflow. Reduce adjustment to speed that provides desired performance.
	Improper duct connections	Verify ductwork is installed per SMACNA and ASHRAE guidelines.
	Duct obstruction	Verify no obstructions. Verify all dampers are full open while fan operates.
	Improperly set dampers	Verify proper inlet air to unit.
	Dirty coil	Check cleanliness of coil. Dirty coil fins will restrict airflow.
	Dirty filters	Check for dirty or blocked filters. Replace as needed.
Damaged or blocked blower	Verify blower rotates freely. Clear blockage.	

TROUBLESHOOTING (CONTINUED)

PSC MOTOR (CONTINUED)		
PROBLEM	POSSIBLE CAUSE	CORRECTIVE ACTION
FAN MOTOR STARTS BUT STOPS. [PSC MOTOR]	Voltage or ground loss at motor	Verify proper voltage and ground at motor.
	Blower blocked	Clear blockage. Verify blower rotates freely with motor disconnected.
	Loss of fan speed command	Verify operation of thermostat or controller. If 24v unit, verify fan speed command at relay board. Refer to fan relay board troubleshooting guide.
	Motor overloaded	Use amp meter to verify motor amps. Disconnect power to unit. Verify motor rotates freely by hand with blower disconnected. If not, replace motor.
	Open ductwork	Verify ducts sealed properly.
	Motor overheated due to lack of airflow	Verify dampers, if present, are not closed. Verify there are no obstructions in the discharge ductwork and/or at the plenum opening. Verify filter is not dirty and does not obstruct airflow.
	Voltage or ground loss at motor	Verify proper voltage and ground at motor power terminals.
	Motor fault or end of life	Replace motor.
	Faulty motor harness	Reseat connector and verify operation. Disconnect motor harnesses and verify continuity. Replace motor harness.
FAN SPEED FLUCTUATES [PSC MOTOR]	Fan speed adjustment outside operating range	If fan speed controller present, adjust fan speed control screw to full clockwise position. Verify that motor speed stabilizes. Reduce adjustment.
	Loose motor wiring	Reseat motor connector. Tighten all motor connections.
	Loose control wiring	Verify and/or tighten all control connections.
	Intermittent control device	Verify operation of any control device such as drain pan float switch, freeze stat, thermostat, etc. When in doubt, jumper out and verify fan operation.
	Blower set screw loose	Remove power from unit. Tighten screw onto motor shaft.
	Improper duct connections	Verify proper ductwork to unit. Verify ductwork is installed per SMACNA and ASHRAE guidelines. Improper ductwork can cause turbulence at the motor.
	ESP (external static pressure) too high	Verify dampers, if present, are not closed. Verify there are no obstructions in the discharge ductwork and/or at the plenum opening. Verify filter is not dirty and does not obstruct airflow.
EXCESSIVE FAN NOISE	Motor mounting bolts loose	Tighten motor mounting bolts.
	Motor shaft bent	Replace motor.
	Motor bearing end of life	Disconnect power from unit. Verify motor rotates freely by hand with blower disconnected.
	Motor overloaded	Verify static pressure per system design. Use amp meter to verify motor amps. Disconnect power to unit. Verify motor rotates freely with power disconnected. If not, replace motor.
	Motor end of life	Use amp meter to verify motor amps. Replace motor.
	Dirty filters	Verify filters. Replace as needed.
	Obstructed airflow	Verify blower is unobstructed. Verify no duct obstruction. Verify dampers are full open.
	Improper duct connections	Verify ductwork is installed per SMACNA and ASHRAE guidelines.
	Static pressure too low	Verify static pressure per system design.
	Improperly balanced system	Verify airflow through connected ductwork
	Fan wheel rubbing on fan housing	Remove power from unit. Align wheel in housing.
	Loose fan wheel	Remove power from unit. Align wheel in housing and tighten.
Damaged fan wheel	Inspect fan wheel to verify fins are not bent. Replace blower as needed.	
Imbalanced fan wheel	Inspect fan wheel. Replace as needed.	

TROUBLESHOOTING (CONTINUED)

EC MOTOR		
PROBLEM	POSSIBLE CAUSE	CORRECTIVE ACTION
NO AIRFLOW [EC MOTOR]	No demand	Verify thermostat or control is calling for heating or cooling.
	Fan speed is not commanded	Verify fan run command is present at Fan Relay Board.
	No power to motor. Possible blown fuse or open circuit breaker	Verify line voltage at motor terminals. Replace fuse or reset circuit breaker as needed.
	Incorrect voltage applied	Verify proper voltage to unit per unit label.
	Improper wiring connections	Verify wiring. If Fan Coil Relay board present, verify all jumpers and harnesses installed on Fan Relay Board. Refer to Fan Coil Relay Board Troubleshooting Guide.
	Three speed switch in OFF position	Verify three speed switch, if present, is set to desired speed.
	Loss of 24V power	Refer to Fan Relay Board Troubleshooting Guide.
	Drain pan float switch tripped	If drain pan float switch is present, verify drain pan is not full. Verify operation of float switch. Adjust switch position if needed.
	Drain pan float switch fault	Verify operation of drain pan float switch, if present. Disconnect switch and use volt-ohm meter to verify continuity of switch and of wiring. Replace switch if faulty.
	Low temperature cutout has tripped	If low temperature cutout is present. Examine coil for signs of freezing. Verify adjustment of freeze stat. Disconnect switch and use volt-ohm meter to verify continuity. Replace switch if faulty.
	Blower jammed	Remove power from unit. Clear blockage. Verify blower is not damaged and rotates freely while motor is not energized.
	Motor seized	Remove power from unit. Verify motor rotates freely by hand with blower disconnected. If not, replace motor. Note: EC motors may not rotate freely as the rotor aligns with the stator magnets."
	Motor overloaded	Verify motor is not overheated. Remove power from unit. Check to ensure blower rotates freely with motor disconnected. Verify proper duct static. Wait for motor to cool down and verify motor start. If motor overheats again, replace motor.
PWM board faulted	Refer to PWM board status LEDs. Verify voltage input, wiring and connections. Refer to PWM board IOM. Replace PWM board if fault returns.	
NO AIR FLOW [EC MOTOR]	No control signal	EC motors may run at idle speed if they lose PWM signal while enabled. Verify PWM signal at motor connector. Refer to PWM board IOM.
	Wiring harness improperly seated	Unplug harness and re-install, making sure plugs are fully seated.
	Wiring harness(es) open or intermittent	Replace harness(es). Refer to PWM board IOM.
	Damaged motor harness	Replace motor harness.
FAN MOTOR SURGES [EC MOTOR]	Loose motor wiring	Reseat motor connector. Tighten all motor connections.
	Loose control wiring	Verify and/or tighten all control connections.
	Intermittent control device	Verify operation of any control device such as drain pan float switch, freeze stat, thermostat, etc. When in doubt, jumper out and verify fan operation.
	[EC motor] Fan speed adjustment outside operating range	Refer to Fan Calibration curve on unit. Adjust speed on PWM Controller to value that will allow motor to start. See instructions for Adjusting EC Motor Speed.
	[EC motor] Faulty PWM signal	Verify PWM signal at motor connector. Refer to PWM board IOM.
	Blower Set Screw loose	Tighten Screw onto motor shaft.
	Improper duct connections	Verify proper ductwork to unit. Verify ductwork is installed per SMACNA and ASHRAE guidelines. Incorrectly sized ducts can cause motor surging.
	ESP (external static pressure) too high	Verify dampers, if present, are not closed. Verify there are no obstructions in the discharge ductwork and/or at the plenum opening. Verify filter is not dirty and does not obstruct airflow.

TROUBLESHOOTING (CONTINUED)

EC MOTOR (CONTINUED)		
PROBLEM	POSSIBLE CAUSE	CORRECTIVE ACTION
POOR AIRFLOW PERFORMANCE [EC MOTOR]	Lack of required external static pressure	External static pressure not as designed. Adjust external static pressure to design pressure.
	[24V units] Three speed switch in wrong position	Verify three speed switch, if present, is set to desired speed.
	Poor voltage quality	Verify input voltage within acceptable parameters.
	Speed adjustment outside fan operating range	Refer to Fan Calibration curve on unit. Adjust speed on PWM Controller to value that will allow motor to start. See instructions for Adjusting EC Motor Speed.
	Erratic speed command (in Proportional Control mode)	Verify 2-10V analog signal at Remote Control input terminals.
	Improper duct connections	Verify ductwork is installed per SMACNA and ASHRAE guidelines.
	Duct obstruction	Verify no obstructions. Verify all dampers are full open while fan operates.
	Improperly set dampers	Verify proper inlet air to unit.
	Dirty coil	Check cleanliness of coil. Dirty coil fins will restrict airflow.
	Dirty filters	Check for dirty or blocked filters. Replace as needed.
Damaged or blocked blower	Verify blower rotates freely. Clear blockage.	
FAN MOTOR STARTS BUT STOPS. [EC MOTOR]	Voltage or ground loss at motor	Verify proper voltage and ground at motor.
	Blower blocked	Clear blockage. Verify blower rotates freely with motor disconnected.
	Loss of fan speed command.	Verify operation of thermostat or controller. Verify fan speed command at relay board. Refer to Fan Relay Board Troubleshooting Guide.
	Motor overloaded	Use amp meter to verify motor amps. Disconnect power from unit. Verify motor rotates freely by hand with blower disconnected. If not, replace motor. Note: EC motors may not rotate freely as the rotor aligns with the stator magnets.
	Open ductwork	Verify ducts sealed properly.
	Motor overheated due to lack of airflow	Verify dampers, if present, are not closed. Verify there are no obstructions in the discharge ductwork and/or at the plenum opening. Verify filter is not dirty and does not obstruct airflow.
	Voltage or ground loss at motor	Verify proper voltage and ground at motor power terminals.
	PWM board error or faulted	Refer to PWM board status LEDs. Verify all connections. Cycle power to the board. Refer to PWM board IOM.
	Motor fault or end of life	Replace motor.
FAN MOTOR STARTS BUT STOPS. [EC MOTOR]	Faulty motor harness	Reseat connector and verify operation. Disconnect motor harnesses and verify continuity. Replace motor harness.
EC MOTOR SPEED CANNOT BE ADJUSTED	PWM board error or faulted	Refer to PWM board status LEDs. Verify all connections. Cycle power to the board. Refer to PWM board IOM.
	Improper wiring connections	Verify wiring. If Fan Relay board present, verify all jumpers installed.
	EC wiring harness damaged or improperly seated	Unplug harness and re-install, making sure plugs are fully seated. See section on checking wire harnesses, below. Replace harness if damaged.
	No control signal	EC motors may run at idle speed if they lose PWM signal while enabled. Verify PWM signal at motor connector. Refer to PWM board IOM.
	ESP (external static pressure) too high	Verify dampers, if present, are not closed. Verify there are no obstructions in the discharge ductwork and/or at the plenum opening. Verify filter is not dirty and does not obstruct airflow.
	Motor control failure	Replace motor.
	Motor control failure	Replace motor.
EC MOTOR RUNS IN REVERSE, DOESN'T RESPOND TO SPEED ADJUSTMENT	Motor control failure	Replace motor.

TROUBLESHOOTING (CONTINUED)

EC MOTOR (CONTINUED)		
PROBLEM	POSSIBLE CAUSE	CORRECTIVE ACTION
EXCESSIVE FAN NOISE	Motor mounting bolts loose	Tighten motor mounting bolts.
	Motor shaft bent	Replace motor.
	Motor bearing end of life	Disconnect power from unit. Verify motor rotates freely by hand with blower disconnected. Note: EC motors may not rotate freely as the rotor aligns with the stator magnets.
	Motor overloaded	Verify static pressure per system design. Use amp meter to verify motor amps. Disconnect power to unit. Verify motor rotates freely with power disconnected. If not, replace motor.
	Motor end of life	Use amp meter to verify motor amps. Replace motor.
	Dirty filters	Verify filters. Replace as needed.
	Obstructed air flow	Verify blower is unobstructed. Verify no duct obstruction. Verify dampers are full open.
	Improper duct connections	Verify ductwork is installed per SMACNA and ASHRAE guidelines.
	Static pressure too low	Verify static pressure per system design.
	Improperly balanced system	Verify airflow through connected ductwork.
	Fan wheel rubbing on fan housing	Align wheel in housing.
	Loose fan wheel	Align and tighten.
Damaged fan wheel	Inspect fan wheel to verify fins are not bent. Replace blower as needed.	
Imbalanced fan wheel	Inspect fan wheel. Replace as needed.	

COOLING SYSTEM		
PROBLEM	POSSIBLE CAUSE	CORRECTIVE ACTION
INSUFFICIENT COOLING	Insufficient airflow	Verify proper airflow.
	Dirty water coil	Check cleanliness of water coil. Clean as needed.
	[24V units] Drain pan float switch fault	Verify operation of drain pan float switch, if present. Disconnect switch and use volt-ohm meter to verify continuity of switch and of wiring. Replace switch if faulty.
	Cooling valve not operating properly	Verify cooling valve opens with call for cooling. Verify all manual valves are open.
	Insufficient flow	Verify liquid flow per system design.
	Obstructed coil	Verify coil is unobstructed. Verify all manual valves are open and have liquid flow through system.
	[DX coils] Improper refrigerant charge	Charge to proper cooling.
	[DX coils] Insufficient cooling liquid to coil	Verify coolant flow in coil. Verify proper flow per system design.
UNIT SWEATS	No call for cooling.	Verify cooling signal at 'Y' terminals. Verify thermostat setting/operation.
	Air leak in ducts/unit	Verify integrity of unit. Verify ducts are properly sealed.
	Pipe insulation	Verify pipes are properly insulated.
	Damaged insulation	Verify insulation at point of sweating.
	Unconditioned air to unit	Verify conditioned air to unit.
	Drain pan is clogged	Locate and remove blockage.

TROUBLESHOOTING (CONTINUED)

ELECTRIC HEATER		
PROBLEM	POSSIBLE CAUSE	CORRECTIVE ACTION
ELECTRIC HEAT WILL NOT OPERATE CAUTION: UNIT MAY BE EXTREMELY HOT. TAKE GREAT CARE WHEN TROUBLESHOOTING.	Insufficient airflow	Verify proper airflow.
	Loss of demand	Verify thermostat or control is calling for heating. Verify demand voltage is present at unit.
	[24V units] Loss of demand	Verify 24V control signal at 'W' terminal during demand.
	[24V units] Loss of 24V	Verify integrity of fuse on Fan Relay Board and replace if needed. Refer to Fan Relay Board Troubleshooting Guide.
	No airflow.	Electric heat will not operate unless fan motor is enabled. Verify fan speed is commanded.
	Damaged primary limit wire harness	Disconnect primary limit wire harness (the purple wire harness coming out of the heater section.) Verify continuity across wire harness. If no continuity, check if primary limit is tripped. If primary limit is verified good, remove power from unit, disconnect primary limit wire harness, and measure continuity of wire harness. Replace if bad.
	Primary limit switch tripped.	Verify no loss of demand to unit. Verify that voltage exists on magnetic heater contactor during demand for heat. If demand reaches unit but not contactor, primary limit is tripped. The primary limit switch(es) will auto-reset once the unit cools down. If unit is hot, wait for heater to cool down. This may take up to an hour.
	Secondary limit switch tripped	The secondary limit may be manually reset. If unit is hot, wait for the heater to cool down. This may take up to an hour. Reset switch(es). Verify if heater will start.
	Improper wiring connections	Verify wiring to schematic.
	Open or damaged heater elements	With power removed, disconnect heater wire harnesses. (These are the harnesses with the black plugs.) Use a volt-ohm meter to measure resistance across the electric heat power harness coming out of the heater section. If the meter measures an open or shorted circuit, inspect the heating elements.
	Damaged electric heat wire harness	With power removed, disconnect heater wire harnesses. Use a volt-ohm meter to verify continuity of electric heat power harness wires in the control enclosure section.
Primary Limit switch fault	With power removed and heater cool, remove primary limit switch. Verify continuity across switch. Replace switch if open.	
Secondary Limit switch fault	With power removed and heater cool, remove secondary limit switch. Verify switch is reset. Verify continuity across switch. Replace switch if open.	
ELECTRIC HEAT WILL NOT OPERATE CAUTION: UNIT MAY BE EXTREMELY HOT. TAKE GREAT CARE WHEN TROUBLESHOOTING.	[Magnetic contactor] Electric heat contactor fault	Verify heating demand voltage is at magnetic electric heat contactor control coil terminals. If power is present but contactor is not actuated, replace contactor. To verify contactor: with power removed, unwire contactor and verify continuity across contacts when manually operated. Cover of contactor will need to be removed to access manual operator. Replace contactor if faulty.
	[Solid state relay] electric heat safety contactor fault	Verify control voltage is at magnetic electric heat contactor control coil terminals. If power is present at coil but contactor is not actuated, replace contactor.
	[Solid state relay] Solid State Relay fault	Verify heating demand (control voltage) is at solid state relay control terminals. If power is present but relay is not actuated, replace relay.
	[Solid state relay proportional control] Heat controller fault	Verify DC control signal is present at controller input terminals. Verify that output control voltage to solid state relay varies with variation in input. Replace controller if not.
ELECTRIC HEAT SHUTS DOWN UNEXPECTEDLY CAUTION: UNIT MAY BE EXTREMELY HOT. TAKE GREAT CARE WHEN TROUBLESHOOTING.	Loss of demand	Verify that thermostat or control command signal is not dropping out. Verify voltage is present at unit during demand for heat.
	[24V units] Loss of demand	Verify that signal from thermostat or control is not dropping out. During demand, there needs to be 24V on 'W1' terminal of Fan Relay board.
	Primary limit switch tripped	Verify no loss of demand to unit. Verify that voltage exists on heater contactor during demand for heat. If demand reaches unit but not contactor, primary limit is tripped. The primary limit switch(es) will auto-reset once the unit cools down. If unit is hot, wait for heater to cool down. This may take up to an hour. If limit trips again, verify heater is not overheating.
	Secondary limit switch tripped	The secondary limit may be manually reset. If unit is hot, wait for the heater to cool down. This may take up to an hour. Reset switch(es). If limits trip again, verify heater is not overheating.
	Loss of fan speed command	Heater will not operate if fan is not enabled.
	Intermittent control device	Verify operation of any control device such as drain pan float switch, freeze stat, thermostat, etc. When in doubt, jumper out and verify fan operation.
	Loose wiring	Verify and/or tighten all wiring connections.

TROUBLESHOOTING (CONTINUED)

ELECTRIC HEATER (CONTINUED)		
PROBLEM	POSSIBLE CAUSE	CORRECTIVE ACTION
ELECTRIC HEATER IS OVERHEATING CAUTION: UNIT MAY BE EXTREMELY HOT. TAKE GREAT CARE WHEN TROUBLESHOOTING.	Insufficient airflow	Verify that airflow is sufficient to provide a minimum of 70 CFM per kW of electric heat.
	Improper duct connections	Electric heaters require even airflow across the face of the heater in order to operate properly. Verify ductwork is installed per SMACNA and ASHRAE guidelines.
	Obstructed ductwork	Verify no obstructions. Verify all dampers are full open while fan operates.
	Intermittent fan	Verify fan motor runs continuously, providing even airflow.
	Incorrect voltage applied	Verify proper voltage to unit per unit label.
	Improper wiring connections	Verify wiring to schematic. If Fan Coil Relay board present, verify all jumpers and harnesses installed. Refer to Fan Coil Relay Board Troubleshooting Guide.
	Damaged heater elements	Remove power from unit. Access the heater compartment. Verify heating elements are undamaged.
	Shorted magnetic heater contactor	Remove thermostat or control command signal. Verify no control voltage to heater contactor. If electric heat continues to operate and all wiring has been verified, replace contactor.
	[Solid state relay] Shorted solid state relay	Remove thermostat or control command signal. Verify no control voltage to solid state relay. If electric heat continues to operate and all wiring has been verified, replace solid state relay.
INSUFFICIENT HEATING CAUTION: UNIT MAY BE EXTREMELY HOT. TAKE GREAT CARE WHEN TROUBLESHOOTING	Intermittent demand for heating	Verify that thermostat or control command signal is not dropping out. Verify voltage is continuously present at unit during demand for heat.
	Heater is short cycling	Verify thermostat settings. Verify proper location of thermostat.
	Open or damaged heater elements	With power removed, disconnect heater wire harnesses. (These are the harnesses with the black plugs.) Use a volt-ohm meter to measure the resistance across the electric heat power harness coming out of the heater section. Verify ohms approximately equal to (Unit Volts) ² /Unit kW.
	Loss of stage	Loss of demand for second stage. Verify demand voltage at stage 2 contactor.
	Incorrect voltage applied	Verify proper voltage to unit per unit label.
	Electric heat contactor fault	Verify heating demand voltage is at each electric heat contactor control coil terminals. If power is present but contactor is not actuated, replace contactor. To verify contactor: with power removed, unwire contactor and verify continuity across contacts when manually operated. Cover of contactor will need to be removed to access manual operator. Replace contactor if faulty.
	Primary limit switch cycling	Verify no loss of demand to unit. Verify that voltage exists continuously on heater contactor during demand for heat. If demand reaches unit but not contactor, primary limit is tripped. The primary limit switch(es) will auto-reset once the unit cools down. If unit is hot, wait for heater to cool down. This may take up to an hour. If limit trips again, verify heater is not overheating.

CONNECT WITH US!



1401 N. Plano Rd.
Richardson, TX 75081
tel: 972.680.9136
www.krueger-hvac.com
kruegerinfo@krueger-hvac.com
KHF - Series A IOM: 04/2021
©Krueger 2021. All Rights Reserved.