

KRUEGER

KHFP

HORIZONTAL STANDARD FAN COIL UNIT, SERIES A
REAR RETURN, COOLING AND HEATING

JOB NAME _____
ENGINEER _____
CONTRACTOR _____
TAG _____

SUBMITTAL SHEET

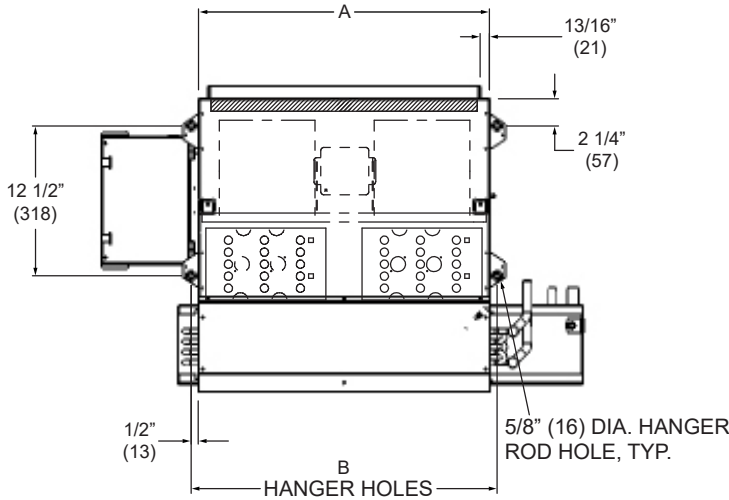

TOP VIEW

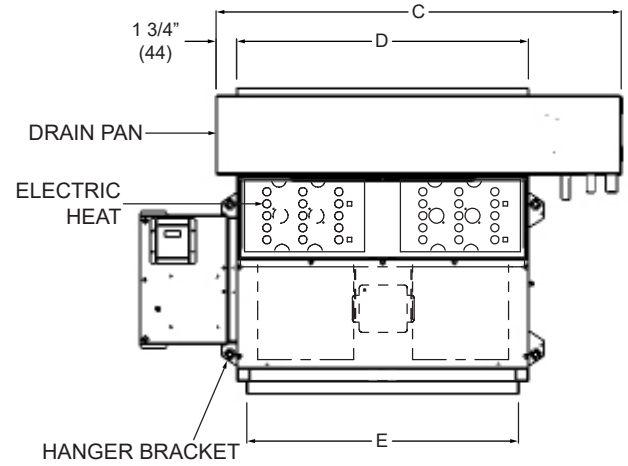

BOTTOM VIEW

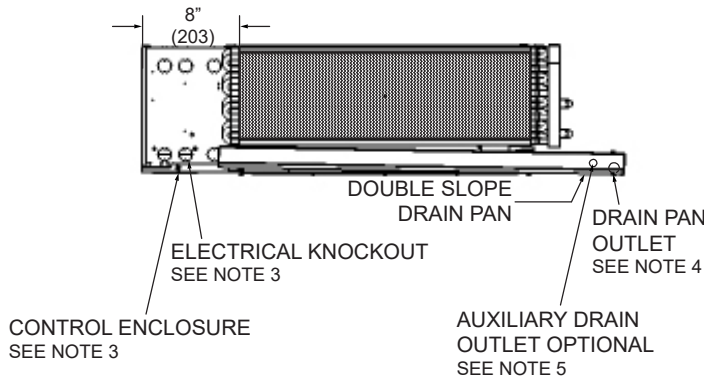

FRONT VIEW

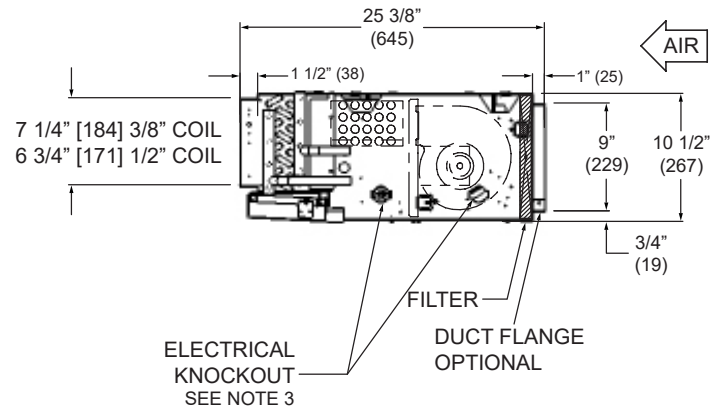

SIDE VIEW

DIMENSIONS					
UNIT SIZE	A	B	C	D	E
02	16" (406)	17 1/4" (438)	25 1/2" (648)	16" (406)	14 3/8" (365)
03	19 1/4" (489)	20 1/2" (521)	28 3/4" (730)	19 1/4" (489)	17 5/8" (448)
04	24 1/4" (616)	25 1/2" (648)	33 3/4" (857)	24 1/4" (616)	22 5/8" (575)
06	31" (787)	32 1/4" (819)	40 1/2" (1029)	31" (787)	29 3/8" (746)
08	38" (965)	39 1/4" (997)	47 1/2" (1206)	38" (965)	36 3/8" (924)
09	42 1/4" (1073)	43 1/2" (1105)	51 3/4" (1314)	42 1/4" (1073)	40 5/8" (1032)
10	52" (1321)	53 1/4" (1353)	61 1/2" (1562)	52" (1321)	50 3/8" (1280)
12	60" (1524)	61 1/4" (1556)	69 1/2" (1765)	60" (1524)	58 3/8" (1483)

NOTE:

- All dimensions in Inches (millimeters). All dimensions $\pm 1/4"$ (6mm). Metric values are soft conversion.
- Left hand unit shown, right hand unit opposite.
- Standard control enclosure is mounted on unit side opposite cooling coil connections. Unit casing includes (6) knockouts on each side. Provide sufficient clearance to access electrical controls and comply with applicable codes and ordinances.
- Standard externally foam coated galvanized steel drain pan has 7/8" ODM copper outlet. Stainless steel drain pan has 3/4" MPT galvanized steel outlet.
- Standard galvanized steel aux. drain pan has 5/8" ODM copper outlet. Stainless steel aux. drain pan has 3/8" MPT galvanized steel outlet.
- See coil connection drawings for coil connection sizes and locations.