

FRONT VIEW

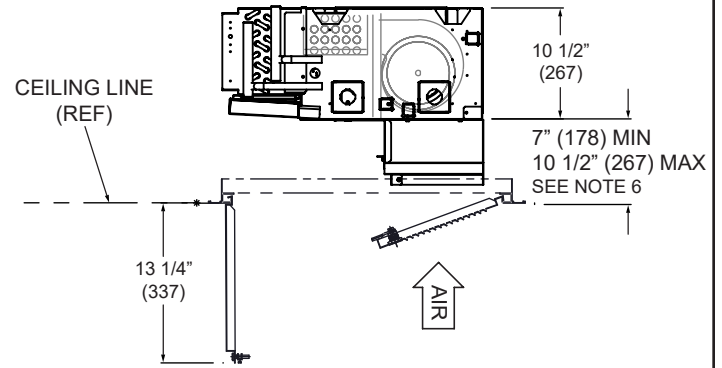

SIDE VIEW

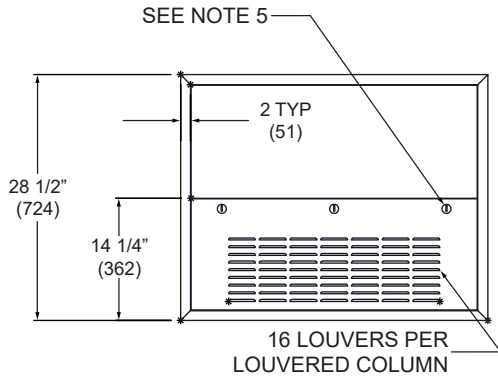

BOTTOM VIEW

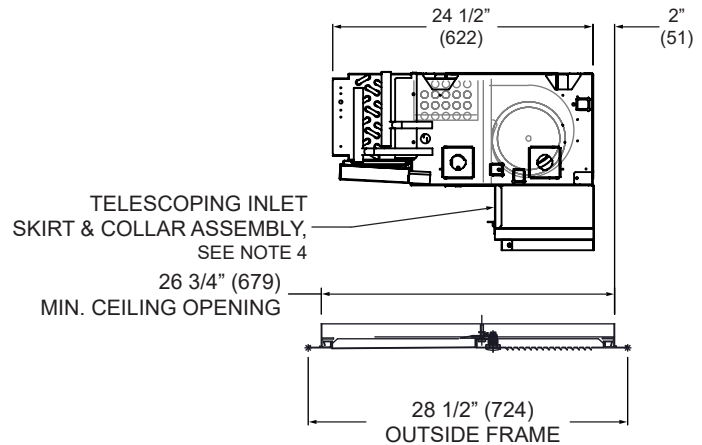

SIDE VIEW

DIMENSIONS			
UNIT SIZE	A	B	C
02	38 1/4" (972)	40 1/4" (1022)	19 1/8" (486)
03	41 1/2" (1054)	43 1/2" (1105)	20 3/4" (527)
04	46 1/2" (1181)	48 1/2" (1232)	23 1/4" (591)
06	53 1/4" (1353)	55 1/4" (1403)	26 5/8" (676)
08	60 1/4" (1530)	62 1/4" (1581)	30 1/8" (765)
09	64 1/2" (1638)	66 1/2" (1689)	32 1/4" (819)
10	74 1/4" (1885)	76 1/4" (1937)	37 1/8" (943)
12	82 1/4" (2089)	84 1/4" (2140)	41 1/8" (1045)

**NOTE:**

1. All dimensions in Inches (millimeters). All dimensions  $\pm 1/4"$  (6mm). Metric values are soft conversion.
2. Left hand unit shown, right hand unit opposite.
3. Portions of the inlet louver not directly below unit inlet may require covering in the field on applications where infiltration of ceiling plenum air into space is undesired.
4. Telescoping skirt and collar assembly must be field adjusted to assure a proper fit between filter frame and louvered inlet panel assembly.
5. 1/4 Turn latch, (2) qty for standard sizes, (3) qty for sizes 10-12.
6. Please reference the external feature space requirements submittal for complete service space requirements. Service access may be limited based on the panels installed in relation to the unit.