

FRONT VIEW  
TRAP DOOR OPENED 1" [25]

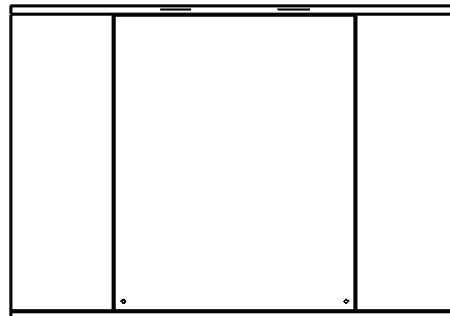

RIGHT VIEW  
TRAP DOOR OPENED 1" [25]



BOTTOM VIEW  
TRAP DOOR OPENED 1" [25]

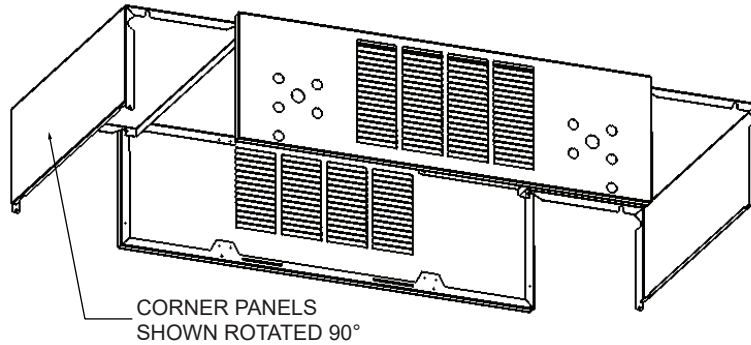

### HEIGHT RESTRICTED APPLICATION



### UNIT INSTALLED

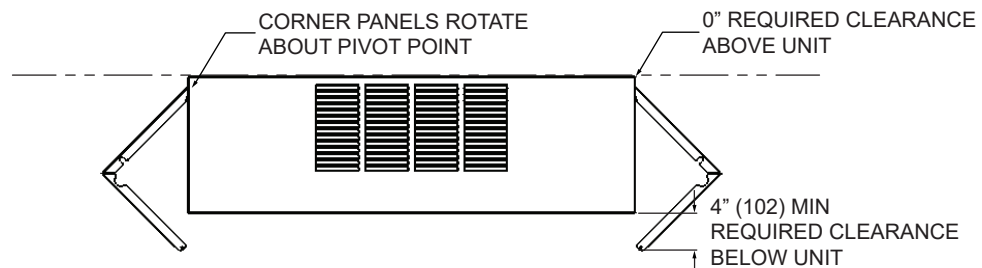

### HALF OPENED

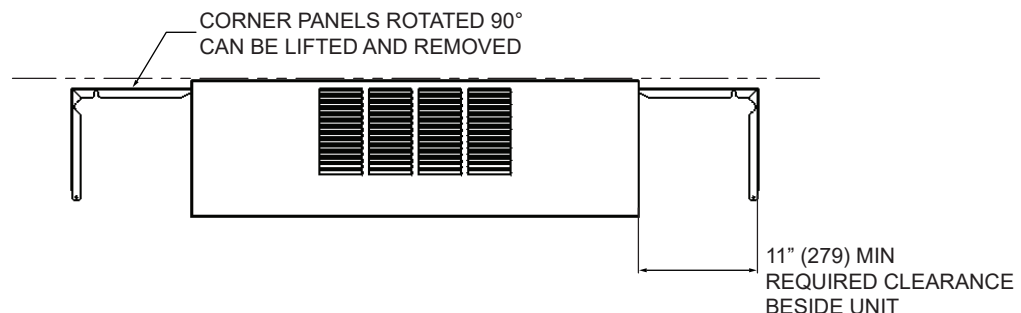

### FULLY OPENED

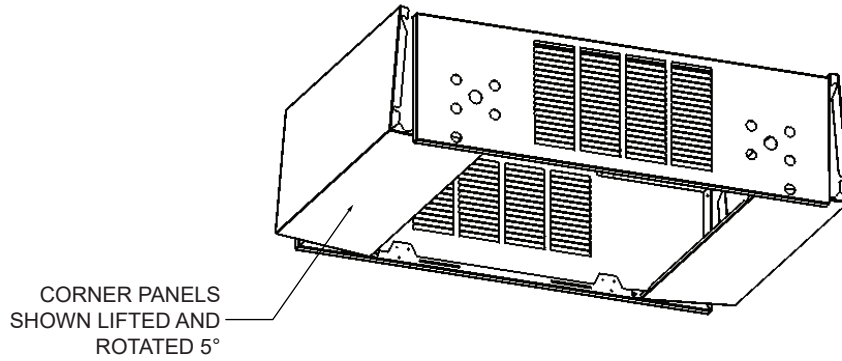

#### WIDTH RESTRICTED APPLICATION

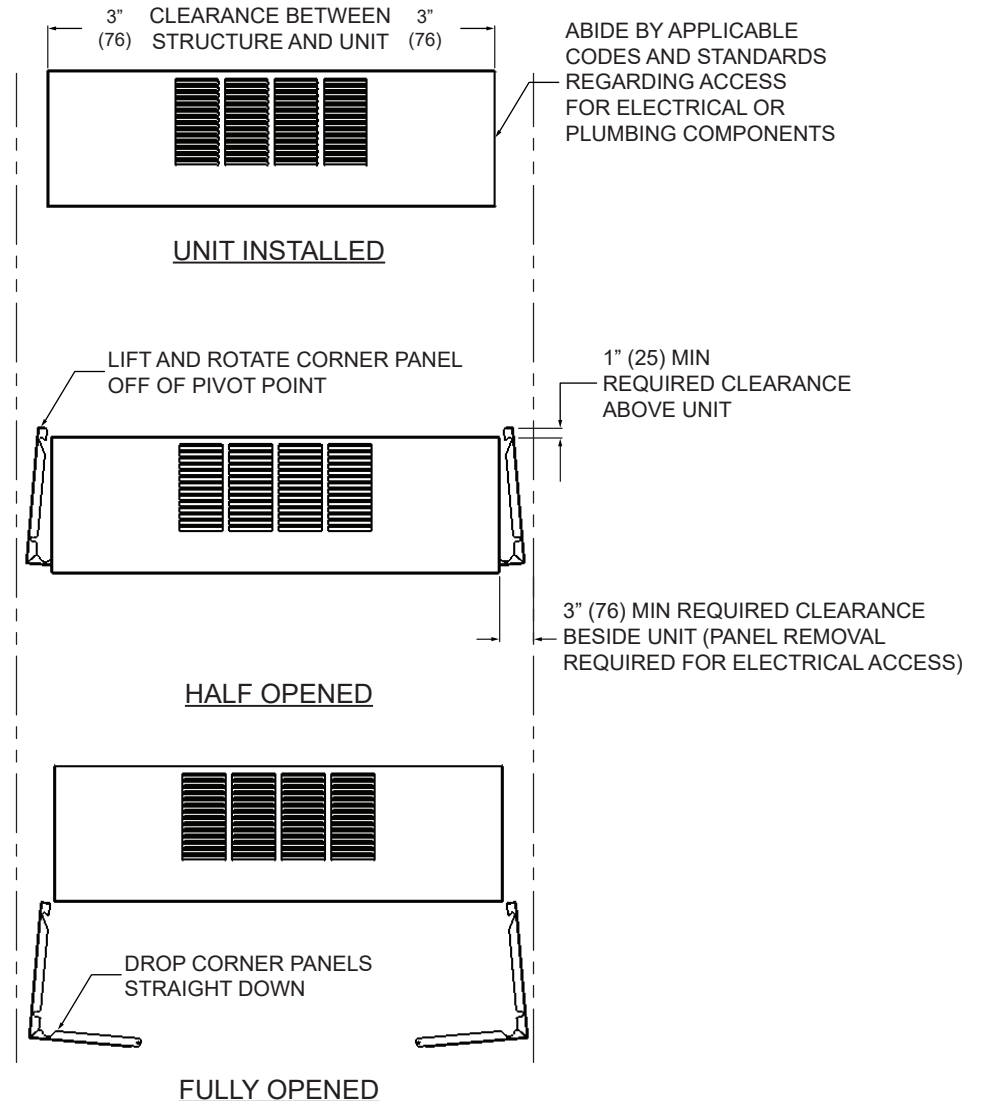

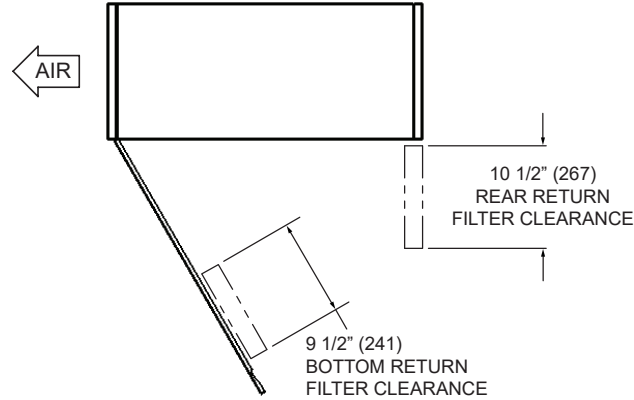

RIGHT VIEW  
FILTER ACCESS DETAIL TRAP DOOR OPENED

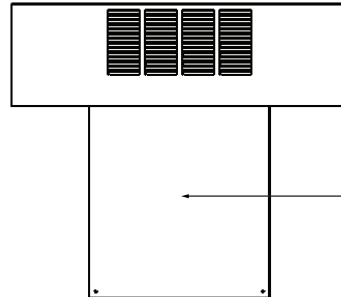

TRAP DOOR RETAINED BY 1/4 TURN  
HARDWARE SWINGS OPEN ON  
INTEGRATED HINGE-FLANGE OPEN  
TRAP DOOR TO ACCESS:

- AIR FILTER
- BLOWER ACCESS PANEL
- ELECTRIC HEAT ACCESS PANEL
- CORNER PANEL MOUNTING HARDWARE

FRONT VIEW  
ACCESS SEQUENCE  
DETAIL 1



AFTER OPENING TRAP DOOR  
CORNER PANELS MAY BE  
REMOVED EACH CORNER PANEL  
RETAINED BY QTY (2) #10 HEX  
HEAD SCREWS OPEN CORNER  
PANELS TO ACCESS:

- ELECTRICAL ENCLOSURE
- VALVE PACKAGE

FRONT VIEW  
ACCESS SEQUENCE  
DETAIL 2