

## LMHS-VP

### ATTENUATED SINGLE DUCT TERMINAL UNIT WITH HOT WATER COIL AND VALVE PACKAGE, PNEUMATIC CONTROLS

## SUBMITTAL SHEET

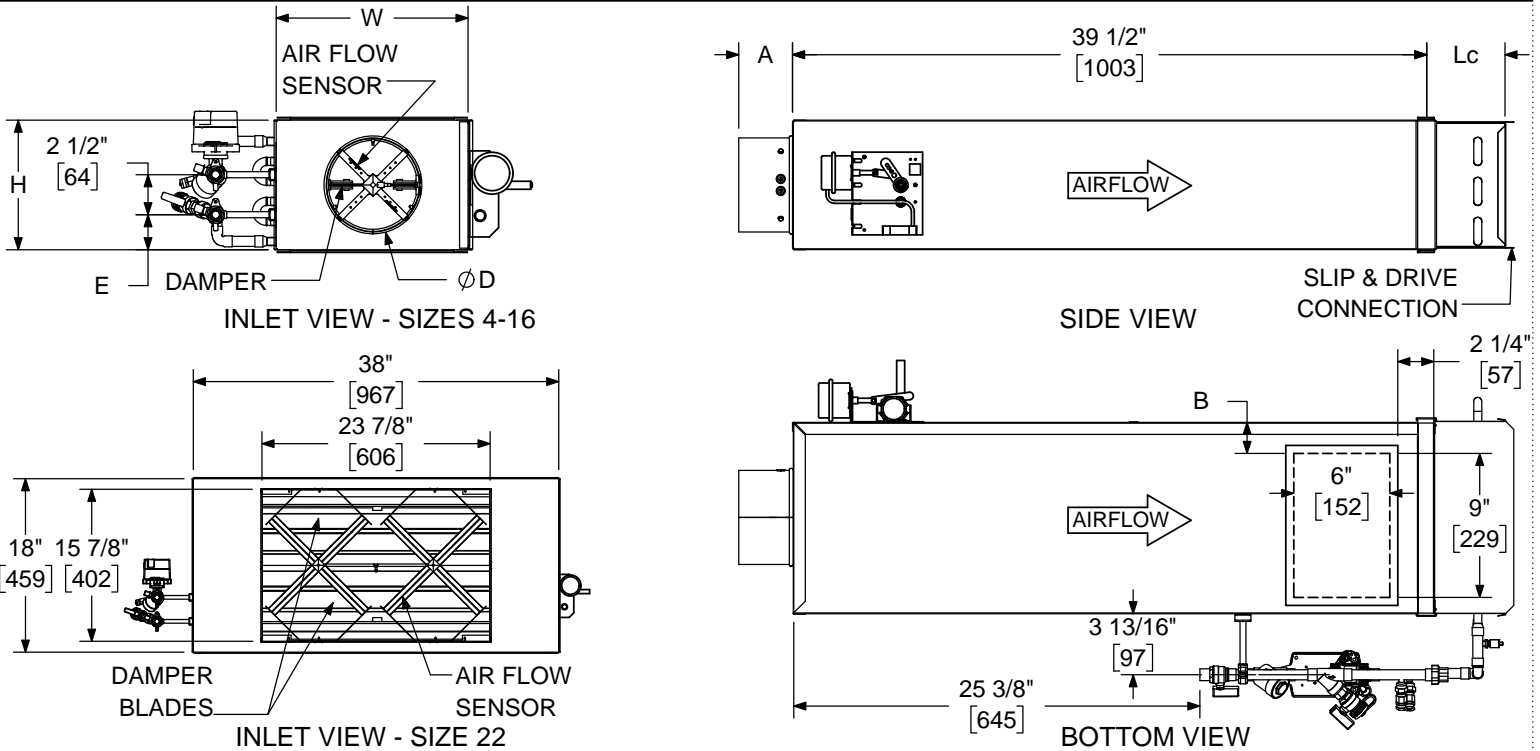

#### STANDARD FEATURES:

- 22 Ga. Zinc coated steel construction
- 1/2" thick dual density fiberglass insulation meeting **NFPA 90A** and **UL 181** safety requirements
- Four quadrant averaging cross flow sensor
- Hot water coils. See form TUS33-ACC-WH00 for dimensions and specifications
- Pneumatic pressure independent controls
- Compressed air consumption: 1.0 scfh @ 20psig
- AHRI 880 certified sound ratings
- 2-way and 3-way valve package available. See form TUS33-ACC-00001 & TUS33-ACC-00002

#### OPTIONAL FEATURES:

- Liners:
  - 1" dual density fiberglass
  - 1/2" Cellular insulation
  - 1" Cellular insulation
  - Sterilwall w/ 1" fiberglass
  - Perf. Double Wall w/ 1" fiberglass
  - Steriliner
  - None
- 20 Ga. Zinc coated steel construction
- Linear averaging sensor
- Left hand control
- Right hand control
- 2-Way valve package
- 3-Way valve package
- Left hand coil connection
- Right hand coil connection
- Bottom access panel
- Cam lock bottom access panel
- Hanger brackets
- Direct acting thermostat
- Reverse acting thermostat
- Pneu. actuator only
- Normally open damper
- Normally closed damper

**NOTE:** Right hand control configuration shown, left hand available.

**DIMENSIONS ARE GIVEN AS INCHES [MM]**

INLET SIZE	NOM MAX CFM [L/s]	W	H	A	B	D	E	Lc
4	230 [109]	12 [305]	8 [203]	5 3/8 [136]	1 1/2 [38]	3 7/8 [98]	2 3/16 [56]	SEE FORM TUS33-ACC- WH00
5	360 [170]	12 [305]	8 [203]	5 3/8 [136]	1 1/2 [38]	4 7/8 [124]	2 3/16 [56]	
6	515 [243]	12 [305]	8 [203]	3 3/8 [86]	1 1/2 [38]	5 7/8 [149]	2 3/16 [56]	
7	700 [330]	12 [305]	10 [254]	3 3/8 [86]	1 1/2 [38]	6 7/8 [175]	3 3/16 [82]	
8	920 [434]	12 [305]	10 [254]	3 3/8 [86]	1 1/2 [38]	7 7/8 [200]	3 3/16 [82]	
9	1160 [547]	14 [356]	12 1/2 [318]	3 3/8 [86]	2 1/2 [64]	8 7/8 [225]	3 3/16 [82]	
10	1430 [674]	14 [356]	12 1/2 [318]	3 3/8 [86]	2 1/2 [64]	9 7/8 [251]	3 3/16 [82]	
12	2060 [972]	16 [406]	15 [381]	3 3/8 [86]	3 1/2 [89]	11 7/8 [302]	3 3/16 [82]	
14	2800 [1321]	20 [508]	17 1/2 [445]	3 3/8 [86]	5 1/2 [140]	13 7/8 [352]	3 3/16 [82]	
16	3660 [1727]	24 [610]	18 [457]	3 3/8 [86]	7 1/2 [191]	15 7/8 [403]	3 3/16 [82]	
22	7000 [3303]	38 [965]	18 [457]	4 1/4 [108]	NA	15 7/8 [403]	3 3/16 [82]	