

LMHS-VP

SINGLE DUCT TERMINAL UNIT

WITH HOT WATER COIL AND VALVE PACKAGE, ELECTRIC CONTROLS

SUBMITTAL SHEET

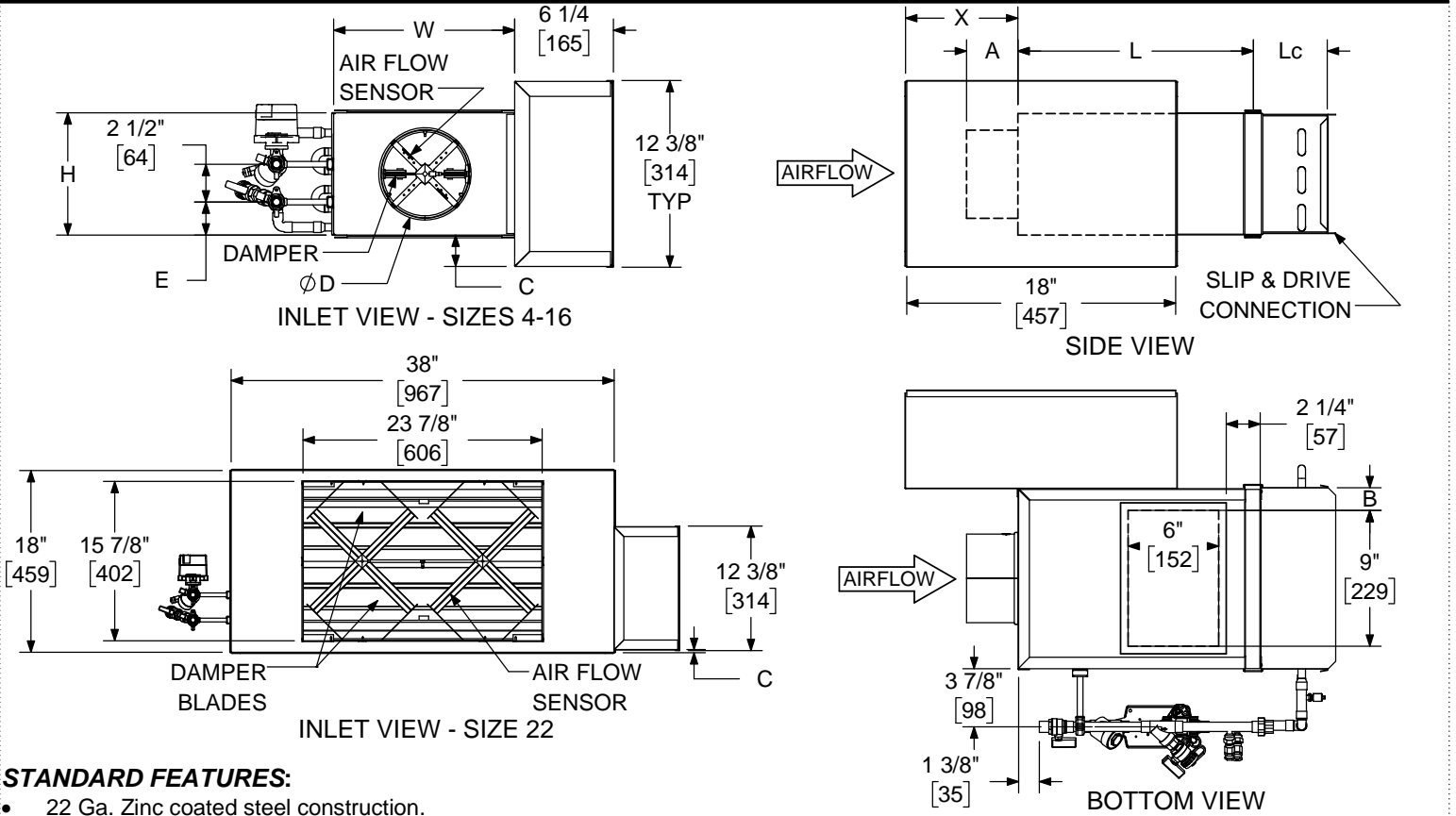

STANDARD FEATURES:

- 22 Ga. Zinc coated steel construction.
- 1/2" dia shaft extending from the unit casing .
- 1/2" thick dual density fiberglass insulation meeting **NFPA 90A** and **UL 181** safety requirements.
- Four quadrant averaging flow sensor.
- Hot water coils. See form TUS33-ACC-WH00 for dimensions and specifications
- Field installation of controls
- AHRI 880 certified sound ratings
- 2-way and 3-way valve package available. See form TUS33-ACC-00001 & TUS33-ACC-00002

OPTIONAL FEATURES:

- Liners:
 - 1" dual density fiberglass
 - 1/2" Cellular insulation
 - 1" Cellular insulation
 - Sterilwall w/ 1" fiberglass
 - Perf. Double Wall w/ 1" fiberglass
 - Steriliner
 - None
- 20 Ga. Zinc coated steel construction
- Linear averaging sensor
- 24 Volt transformer
- Disconnect switch for electronic controls.
- Dust tight control enclosure.
- Left hand control
- Right hand control
- 2-Way valve package
- 3-Way valve package
- Bottom access panel (not size 22)
- Cam lock bottom access panel
- Hanger brackets

NOTE: Right hand control configuration shown, left hand available. Coil connection is always opposite of control handing.

DIMENSIONS ARE GIVEN AS INCHES [MM]

INLET SIZE	NOM MAX CFM [L/s]	L	W	H	A	B	C	D	E	X	Lc
4	230 [109]	15 1/2 [394]	12 [305]	8 [203]	5 3/8 [136]	1 1/2 [38]	2 1/8 [54]	3 7/8 [98]	2 3/16 [56]	7 1/4 [184]	SEE FORM TUS33-ACC-WH00
5	360 [170]	15 1/2 [394]	12 [305]	8 [203]	5 3/8 [136]	1 1/2 [38]	2 1/8 [54]	4 7/8 [124]	2 3/16 [56]	7 1/4 [184]	
6	515 [243]	15 1/2 [394]	12 [305]	8 [203]	3 3/8 [86]	1 1/2 [38]	2 1/8 [54]	5 7/8 [149]	2 3/16 [56]	7 1/4 [184]	
7	700 [330]	15 1/2 [394]	12 [305]	10 [254]	3 3/8 [86]	1 1/2 [38]	1 1/8 [29]	6 7/8 [175]	3 3/16 [82]	7 1/4 [184]	
8	920 [434]	15 1/2 [394]	12 [305]	10 [254]	3 3/8 [86]	1 1/2 [38]	1 1/8 [29]	7 7/8 [200]	3 3/16 [82]	7 1/4 [184]	
9	1160 [547]	15 1/2 [394]	14 [356]	12 1/2 [318]	3 3/8 [86]	2 1/2 [64]	-	8 7/8 [225]	3 3/16 [82]	5 1/4 [133]	
10	1430 [674]	15 1/2 [394]	14 [356]	12 1/2 [318]	3 3/8 [86]	2 1/2 [64]	-	9 7/8 [251]	3 3/16 [82]	5 1/4 [133]	
12	2060 [972]	15 1/2 [394]	16 [406]	15 [381]	3 3/8 [86]	3 1/2 [89]	-	11 7/8 [302]	3 3/16 [82]	5 1/4 [133]	
14	2800 [1321]	15 1/2 [394]	20 [508]	17 1/2 [445]	3 3/8 [86]	5 1/2 [140]	-	13 7/8 [352]	3 3/16 [82]	3 1/4 [83]	
16	3660 [1727]	15 1/2 [394]	24 [610]	18 [457]	3 3/8 [86]	7 1/2 [191]	-	15 7/8 [403]	3 3/16 [82]	3 1/4 [83]	
22	7000 [3303]	15 [381]	38 [965]	18 [457]	4 1/4 [108]	NA	1 1/8 [29]	NA	3 3/16 [82]	5 1/4 [133]	