

KLPS-D Unit Capacities
KLPS-D UNIT CAPACITIES WITH ECM MOTOR

Unit Size	Inlet Size	KLPS-D with ECM Motor							
		Primary Airflow		Fan Airflow		Motor HP	Motor Amps		
		Max.	Min.	Max.	Min.		120V	208/240V	277V
1	4	230	40	775	105	1/3	5.0	3.3	2.6
	5	320	60						
	6	515	90						
	7	700	120						
2	4	230	40	875	135	1/3	5.0	3.3	2.6
	5	320	60						
	6	515	90						
	7	700	120						
3	4	230	40	1000	150	1/3	5.0	3.3	2.6
	5	320	60						
	6	515	90						
	7	700	120						
	8	920	160						
5	6	515	90	1625	250	1/2	7.7	5.0	4.1
	7	700	120						
	8	920	160						
	10	1430	250						

NOTES: KLPS-D maximum primary airflow (CFM) is based on 1.00" WG differential pressure signal from inlet airflow sensor until the value reaches maximum fan CFM for that unit size. A properly balanced unit will be set so the maximum primary CFM is never greater than the fan CFM. Minimum recommended airflow (CFM) is based on 0.03" WG differential pressure of the inlet airflow sensor, or 0 CFM. 0.03" WG is equal to 15%–20% of the nominal flow rating of the terminal. Less than 15%-20% may result in greater than +/-5% control of box flow. Maximum/minimum fan airflow (CFM) is based on 0.10"/0.60" WG external downstream static pressure. See page B2-109 for complete fan curves.

KLPS-D Damper Leakage
KLPS-D, DAMPER LEAKAGE DETAIL

Inlet Size	Damper Leakage		
	1.5" WG CFM	3.0" WG CFM	6.0" WG CFM
4	4	5	7
5	4	5	7
6	4	5	7
7	4	5	7
8	4	5	7
10	4	5	7

NOTES: Damper leakage is measured with the damper fully closed using an actuator. A precision low flow orifice is used upstream of the unit to measure the leakage rate as a function of the measured upstream static pressure. Leakage testing conducted in accordance with ASHRAE 130-2008.

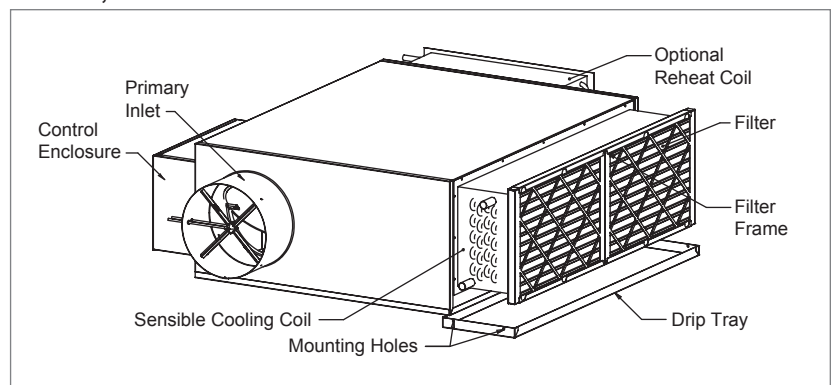
KLPS-D Unit Attributes
KLPS-D, ANGLED VIEW

FAN POWERED TERMINAL UNITS

KLPS