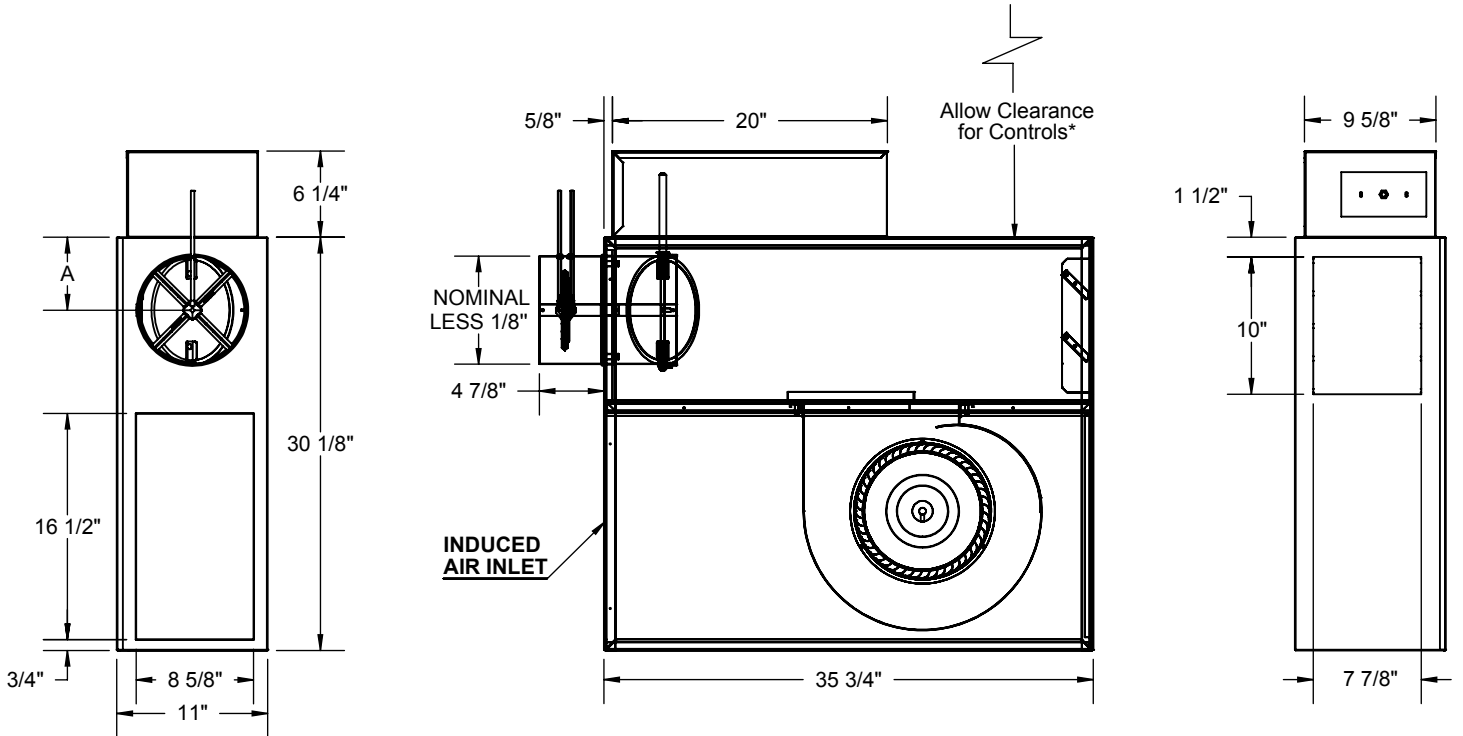

KLPP Unit Size 2
Cooling Only with Electronic Controls
SUBMITTAL SHEET

Inlet Size	A
06"	5"
08"	6"
10"	7"

INLET VIEW
PLAN VIEW - LEFT HAND UNIT
DISCHARGE VIEW
STANDARD FEATURES:

- 20GA. Galvanized Steel Construction
- Steel Control Enclosure for Electronic Components
- 1/2" Thick Dual Density Fiberglass Insulation Meeting NFPA 90A and UL181 Safety Requirements
- 1/6 HP Single Speed, Single Phase, Permanently Lubricated PSC Motor
 - 120V 208/240V 277V
- Field Adjustable Speed Controller
- Bottom Access Panel for Service
- 4 Quadrant Center Averaging Inlet Flow Sensor
- Factory Supplied 24 Volt Control Transformer for Electronic Controls
- ETL Listed
- Performance Data per AHRI Standard 880
- Variety of Direct Digital or Analog Electronic Control Packages Available

*Check NEC for Unit Clearance Requirements

OPTIONAL FEATURES:

- 1/3 HP ECM Motor with Permanently Lubricated Ball Bearings and Constant Airflow Program.
- Manual Control 0-10Vdc Remote Control
- 2-10Vdc Remote Control
- 120V 208/240V 277V
- Liners
 - 1/2" Cellular Insulation No Liner
 - 1/2" Foil Encapsulated Fiberglass Insulation
 - Solid Metal Liner with 1/2" Dual Density Fiberglass
 - Perforated Metal Liner with 1/2" Dual Density Fiberglass
- Left Hand Controls Right Hand Controls
- Motor Toggle Disconnect Switch Motor Fusing
- Dust Tight Control Enclosure Hanger Brackets
- Linear Averaging Inlet Flow Sensor
- Construction Type Air Filter – 18" x 11" x 1"