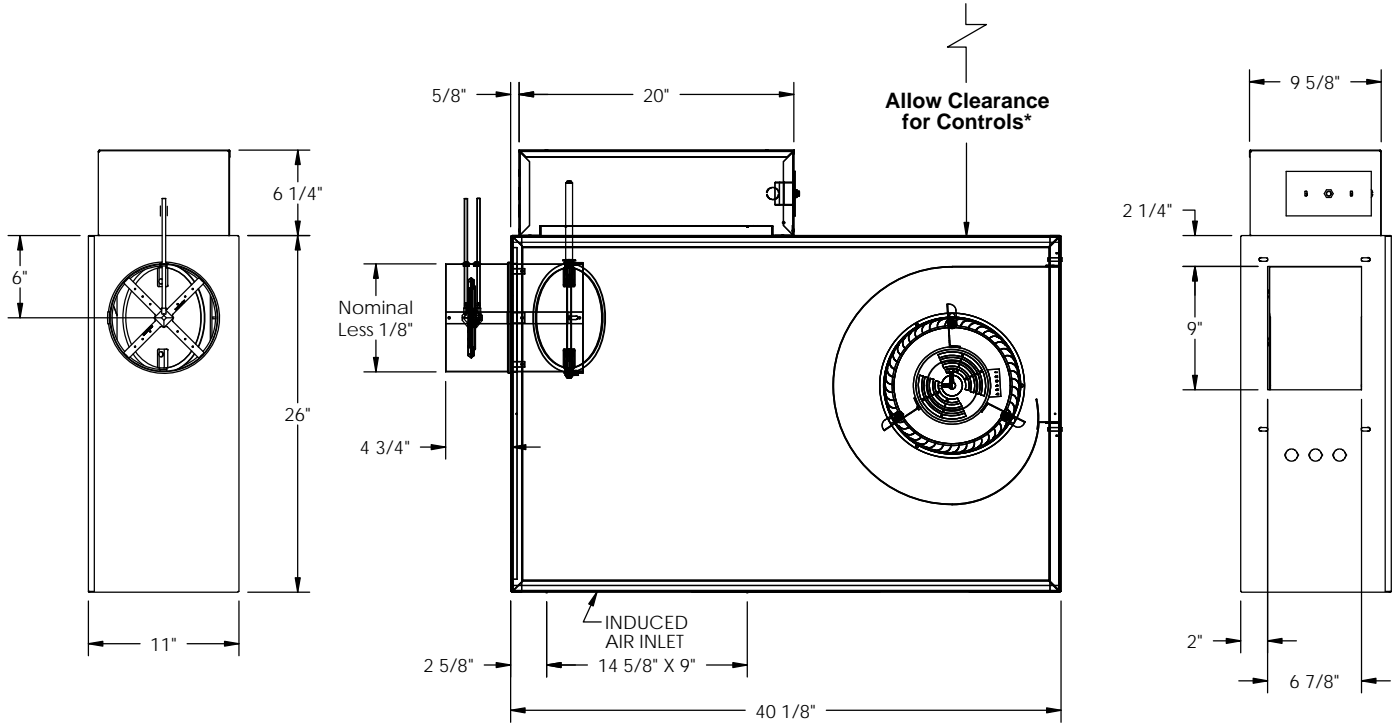

**KLPS Unit 3**
*Cooling Only with Electronic Controls*
**SUBMITTAL SHEET**

Unit Size	Inlet Size
3	08"
3	10"

**INLET VIEW**
**PLAN VIEW - LEFT HAND UNIT**
**DISCHARGE VIEW**
**STANDARD FEATURES:**

- 20GA. Galvanized Steel Construction
- Steel Control Enclosure for Electronic Components
- 1/2" Thick Dual Density Fiberglass Insulation Meeting NFPA 90A and UL181 Safety Requirements
- 1/4 HP Single Speed, Single Phase, Permanently Lubricated PSC Motor
  - 120V     208/240V     277V
- Field Adjustable Speed Controller
- Bottom Access Panel for Service
- 4 Quadrant, Center Averaging Inlet Flow Sensor
- Factory Supplied 24 Volt Control Transformer for Electronic Controls
- ETL Listed
- Performance Data per AHRI Standard 880
- Variety of Direct Digital or Analog Electronic Control Packages Available

\* Check NEC for Unit Clearance Requirements

**OPTIONAL FEATURES:**

- 1/3 HP ECM Motor with Permanently Lubricated Ball Bearings and Constant Airflow Program.
- Manual Control                       0-10Vdc Remote Control
- 2-10Vdc Remote Control
- 120V                       208/240V                       277V
- Liners
  - 1/2" Cellular Insulation                       No Liner
  - 1/2" Foil Encapsulated Fiberglass Insulation
  - Solid Metal Liner with 1/2" Dual Density Fiberglass
  - Perforated Metal Liner with 1/2" Dual Density Fiberglass
- Construction Type Air Filter – 17" x 11" x 1"
- Merv Type 8 Air Filter – 17" x 11" x 1"
- Linear Averaging Inlet Flow Sensor
- Left Hand Controls                       Right Hand Controls
- Motor Toggle Disconnect Switch                       Motor Fusing
- Dust Tight Control Enclosure
- Hanger Brackets
- Dual Access Panels for Service
- Cam-Locks (Dual Access Panel Only)