

DIMENSIONAL DATA | KBVD | SINGLE BLOWER

BLOWER COILS | DIRECT DRIVE

KBHD, KBVD

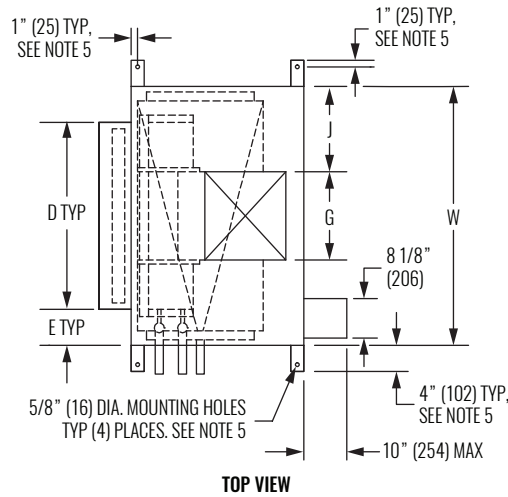

TOP VIEW

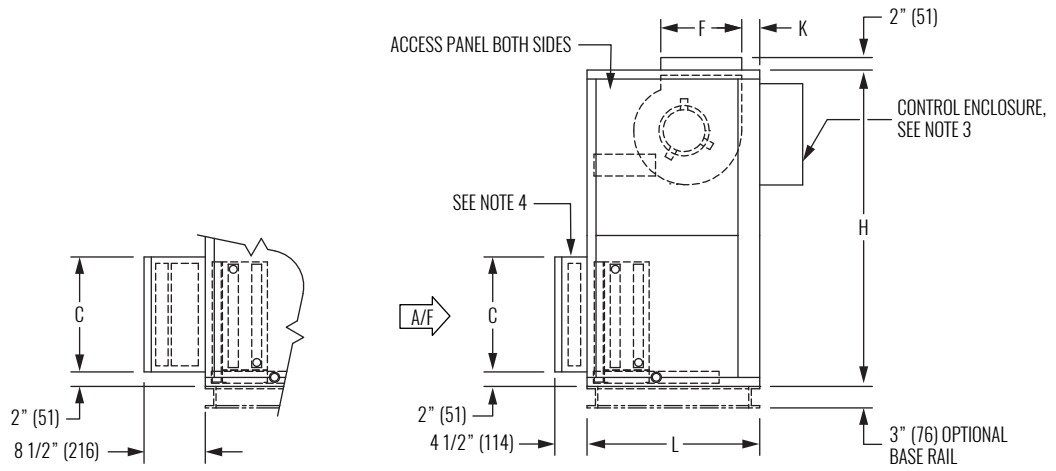

HIGH EFFICIENCY FILTER RACK

STANDARD FILTER RACK

SIDE VIEWS

SIZE	FAN SIZE	L	W	H	C	D	E	F	G	J	K
08	9" x 6" (229 x 152)	24" (610)	30" (762)	44" (1118)	16" (406)	20" (508)	5" (127)	10 3/8" (264)	8 3/8" (213)	10 7/8" (276)	2 1/2" (64)
12	9" x 6" (229 x 152)	24" (610)	36" (914)	44" (1118)	16" (406)	25" (635)	5 1/2" (140)	10 3/8" (264)	8 3/8" (213)	13 7/8" (352)	2 1/2" (64)
16	10" x 8" (254 x 203)	24" (610)	44" (1118)	44" (1118)	16" (406)	39 1/2" (1003)	2 1/4" (57)	11 1/2" (292)	10 5/8" (270)	16 3/4" (425)	2 1/2" (64)
20	10" x 8" (254 x 203)	30" (762)	50" (1270)	50" (1270)	16" (406)	44 1/2" (1130)	2 3/4" (70)	11 1/2" (292)	10 5/8" (270)	19 3/4" (502)	2 1/2" (64)
30	10" x 8" (254 x 203)	30" (762)	59" (1499)	56" (1422)	25" (635)	51" (1295)	4" (102)	11 1/2" (292)	10 5/8" (270)	24 1/4" (629)	10" (254)
40	10" x 8" (254 x 203)	30" (762)	68" (1727)	59" (1499)	25" (635)	59" (1499)	4 1/2" (114)	11 1/2" (292)	10 5/8" (270)	28 3/4" (730)	10" (254)

NOTES:

- All dimensions are inches (millimeters). All dimensions are $\pm 1/4"$ (6mm). Metric values are soft conversion.
- Right hand unit shown, left hand unit opposite. Motor/drive location may be specified Left or Right Hand. Standard control enclosure location matches motor/drive position.
- Provide sufficient clearance to permit access to controls and comply with applicable codes and ordinances.
- Flat filter rack may be located at unit inlet as required. See page F2-89 for filter rack details.
- Base rail is optional on the base unit. Base rails must be used with mixing box.
- See coil connection detail drawings for coil connection sizes and locations.
- Drawings are not to scale and are not for installation purposes.

DIMENSIONAL DATA | BLOW THRU UNIT, ELECTRIC HEAT

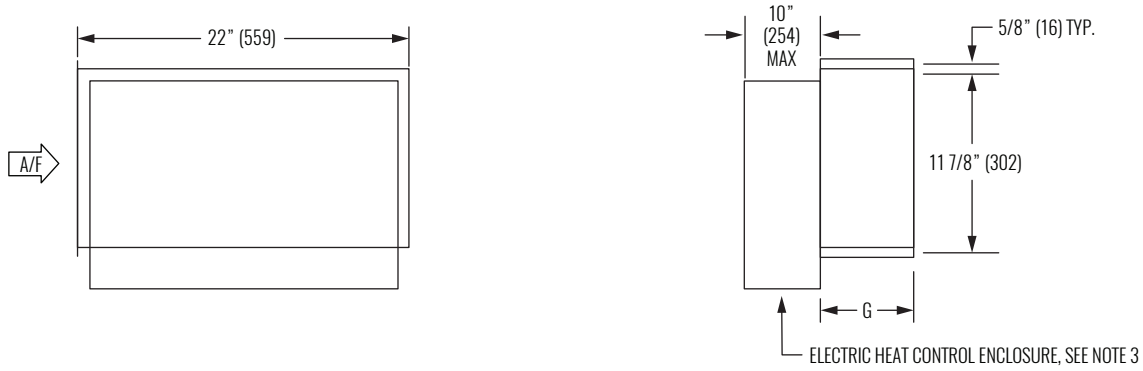

SINGLE BLOWER ELECTRIC HEAT SECTION

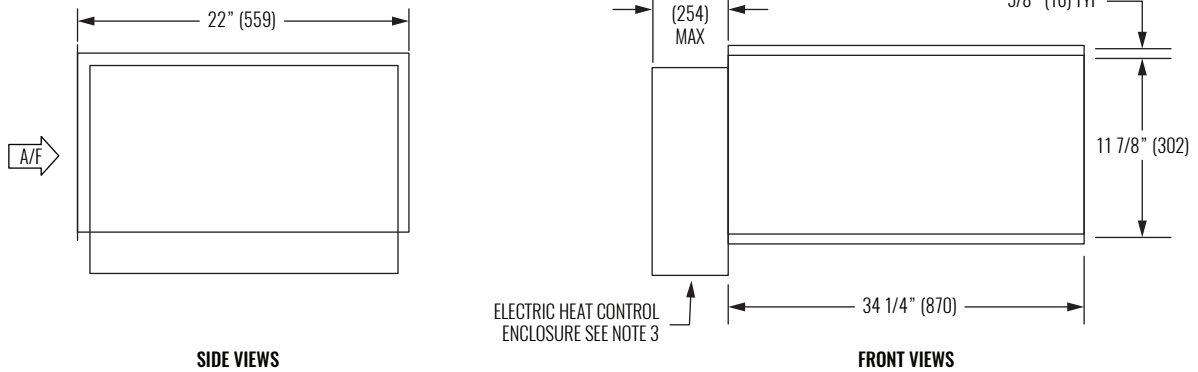

SIDE VIEWS

FRONT VIEWS

DUAL BLOWER ELECTRIC HEAT SECTION

UNIT SIZE	WEIGHT LBS (KG)		G
	SINGLE BLOWER	DUAL BLOWER	
08	45" (20)	-	8 3/4" (222)
12	45" (20)	-	8 3/4" (222)
16	45" (20)	-	10 3/4" (273)
20	45" (20)	-	10 3/4" (273)
30	45" (20)	100" (45)	10 3/4" (273)
40	45" (20)	140" (64)	10 3/4" (273)

NOTES:

1. All dimensions are inches (millimeters). All dimensions are $\pm 1/4"$ (6mm). Metric values are soft conversion.
2. Motor/drive location may be specified left or right hand. Standard control enclosure location matches motor/drive position.
3. Provide sufficient clearance to permit access to controls and comply with applicable codes and ordinances.
4. Available for horizontal discharge only.
5. To prevent sweating for units configured with an uninsulated blow-thru heat section, ensure that insulation is field-installed prior to cooling mode operation.
6. Drawings are not to scale and are not for installation purposes.

KBHD, KBVD

Blower Coils | Horizontal and Vertical Direct Drive



DIMENSIONAL DATA | STANDARD MIXING BOX

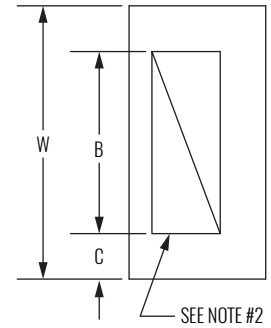
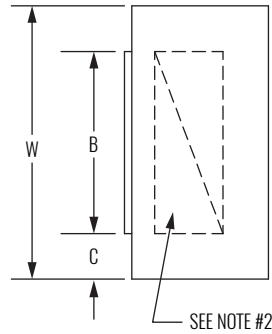
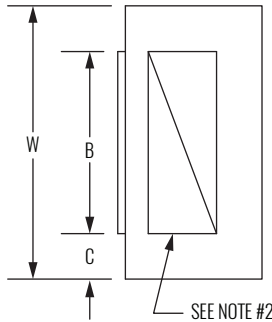

TOP VIEWS

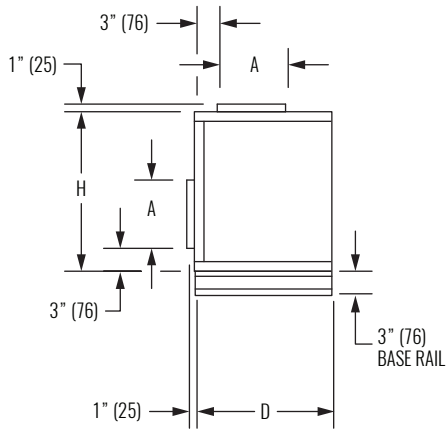

TOP / REAR INLET

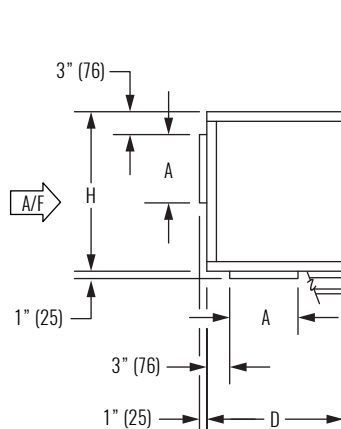

BOTTOM / REAR INLET

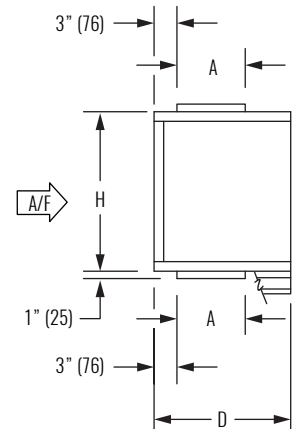

TOP / BOTTOM INLET

SIDE VIEWS

UNIT SIZE	H	W	A	B	C	D
08	21" (533)	30" (762)	9" (229)	18" (457)	6" (152)	18" (457)
12	21" (533)	36" (914)	9" (229)	24" (610)	6" (152)	18" (457)
16	21" (533)	44" (1118)	9" (229)	30" (762)	7" (178)	18" (457)
20	21" (533)	50" (1270)	12" (305)	36" (914)	7" (178)	21" (533)
30	30" (762)	59" (1499)	12" (305)	45" (1143)	7" (178)	21" (533)
40	30" (762)	68" (1727)	15" (381)	48" (1219)	10" (254)	24" (610)

NOTES:

1. All dimensions are inches (millimeters). All dimensions are $\pm 1/4"$ (6mm). Metric values are soft conversion.
2. Damper drive rods are internal, located on both sides of unit.
3. Mixing box includes space for standard flat filter rack.
4. Base rails must be used with mixing box.
5. Drawings are not to scale and are not for installation purposes.

DIMENSIONAL DATA | STANDARD FLAT FILTER RACK

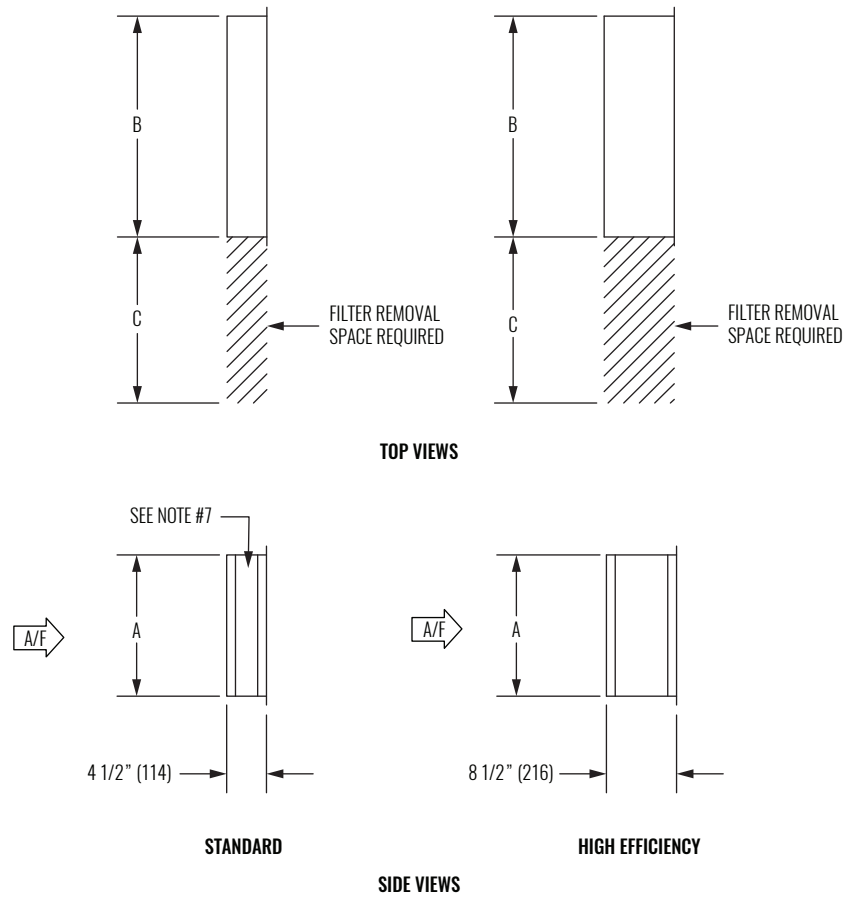

SIZE	A	B	C	QTY & SIZE FILTERS
08	16" (406)	20" (508)	20" (508)	(1) 16" x 20"
12	16" (406)	25" (635)	25" (635)	(1) 16" x 25"
16	16" (406)	39 1/2" (1003)	20" (508)	(1) 16" x 20"
20	16" (406)	44 1/2" (1130)	25" (635)	(1) 16" x 20" (1) 16" x 25"
30	25" (635)	51" (1295)	25" (635)	(1) 16" x 25" (1) 20" x 25"
40	25" (635)	59" (1499)	25" (635)	(1) 20" x 25"

NOTES:

1. All dimensions are inches (millimeters). All dimensions are $\pm 1/4"$ (6mm). Metric values are soft conversion.
2. Flat filter rack may be located at unit inlet as required.
3. Standard rack will accept 1" or 2" thick filters.
4. High efficiency rack will accept nominal 2" and/or 4" thick filters.
5. High efficiency rack not available on units with filter rack.
6. 1" duct connection space provided on entering side of rack for connection of field ductwork.
7. Hinged cover provided on both sides of externally mounted filter racks. Internal standard filter racks have pivoting bar type filter retainer.
8. See individual unit submittal for location of filter rack on unit.
9. Drawings are not to scale and are not for installation purposes.