

KBHD Dual Blower Arr. 1

DIRECT DRIVE DUAL BLOWER COIL UNIT
DISCHARGE ARGT. 1

JOB NAME _____
ENGINEER _____
CONTRACTOR _____
TAG _____

SUBMITTAL SHEET

NOTES:

1. All dimensions are in Inches [millimeters]. All dimensions are $\pm 1/4"$ [6mm]. Metric values are soft conversion.
2. Right hand unit shown, Left hand unit opposite. Motor/drive location may be specified Left or Right Hand. Standard control enclosure location matches motor/drive position.
3. Provide sufficient clearance to permit access to controls and comply with applicable codes and ordinances.
4. See drawing BCS-KBOD-ACFR0 for filter rack details.
5. Base rail is optional on the base unit. See drawing BCS-KBOD-ACEB0. Base rails must be used with mixing box.
6. See coil connection detail drawings for coil connection sizes and locations.

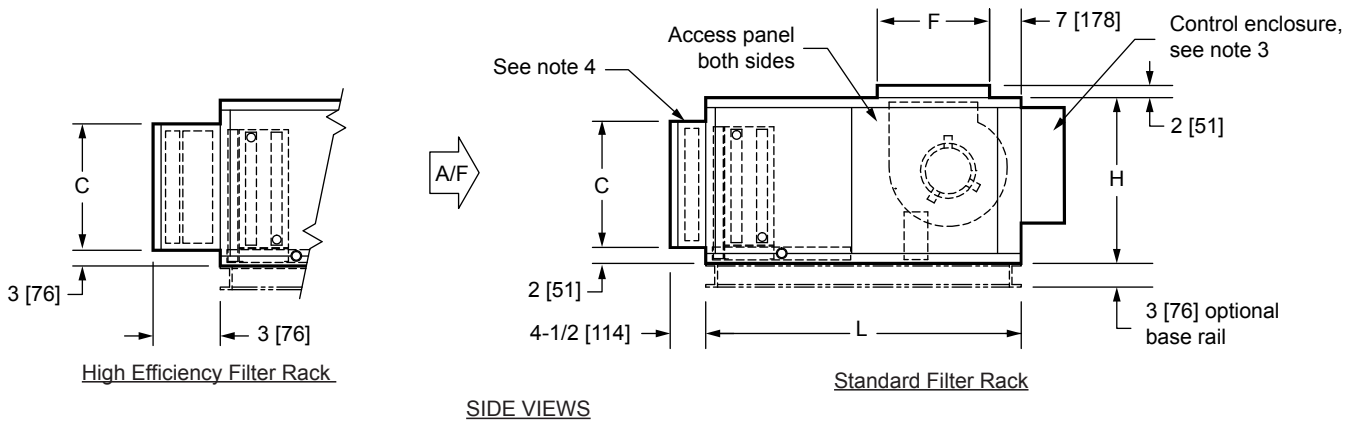
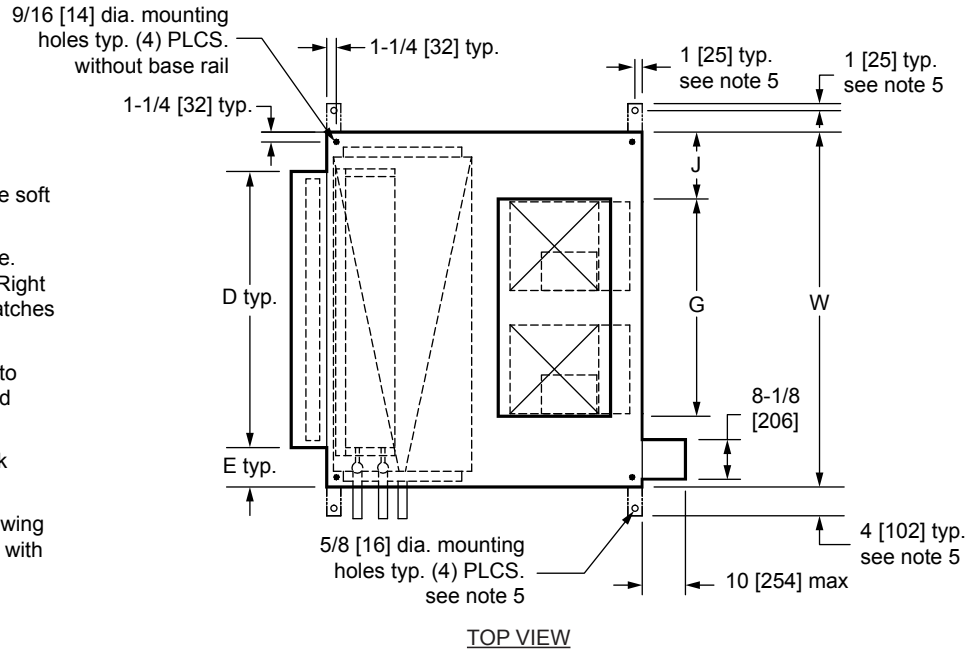

DIMENSIONS										
UNIT SIZE	FAN SIZE	L	W	H	C	D	E	F	G	J
30	10 x 8 [254 x 203]	46 [1168]	59 [1499]	30 [762]	25 [635]	51 [1295]	4 [102]	18 [457]	36 1/2 [927]	11 1/4 [286]
40	10 x 8 [254 x 203]	46 [1168]	68 [1727]	30 [762]	25 [635]	59 [1499]	4 1/2 [114]	18 [457]	36 1/2 [927]	15 3/4 [400]