

## KBVD Arr. 2 w/Mixing Box

DIRECT DRIVE BLOWER COIL UNIT  
 BASIC UNIT - DISCHARGE ARGT. 2 W/MIXING BOX

## SUBMITTAL SHEET

### NOTES:

- All dimensions are in Inches [millimeters].  
 All dimensions are  $\pm 1/4"$  [6mm]. Metric values are soft conversion.
- Right hand unit shown, Left hand unit opposite.  
 Motor/drive location may be specified Left or Right Hand. Standard control enclosure location matches motor/drive position.
- Provide sufficient clearance to permit access to controls and comply with applicable codes and ordinances.
- See drawing BCS-KBOD-ACFR0 for filter rack details.
- Outside and return air damper linkage is optional.
- See coil connection detail drawings for coil connection sizes and locations.
- High efficiency filter rack not available with mixing box.

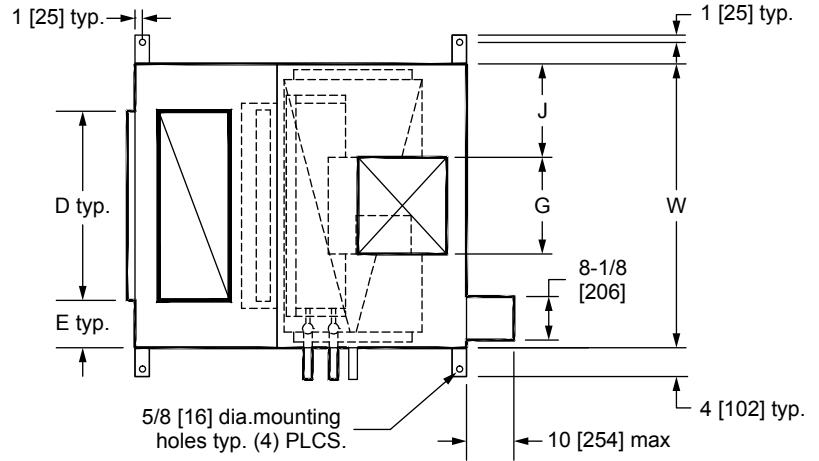

TOP VIEW

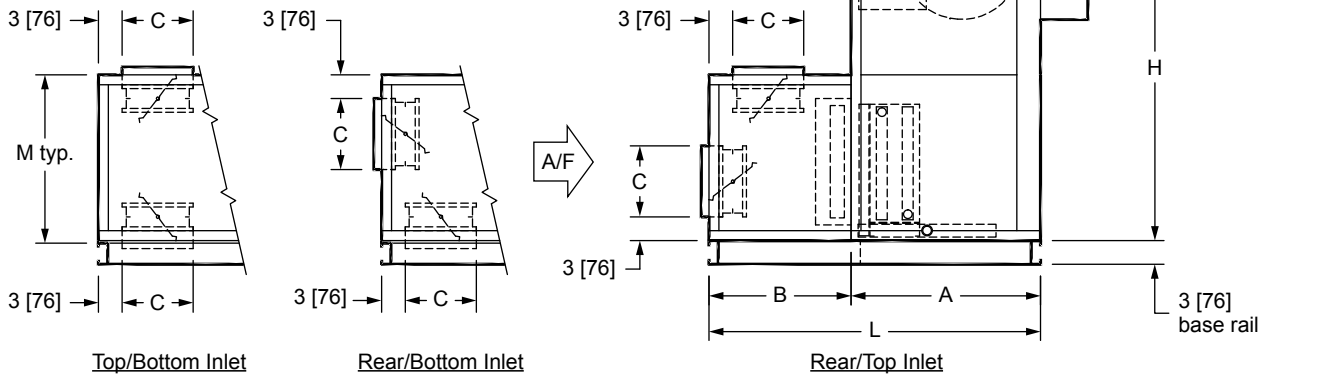

SIDE VIEWS

DIMENSIONS														
UNIT SIZE	FAN SIZE	L	W	H	A	B	C	D	E	F	G	J	K	M
08	9 x 6 [229 x 152]	42 [1067]	30 [762]	44 [1118]	24 [610]	18 [457]	9 [229]	18 [457]	6 [152]	10-3/8 [264]	8-3/8 [213]	10-7/8 [276]	2 -1/2 [64]	21 [533]
12	9 x 6 [229 x 152]	42 [1067]	36 [914]	44 [1118]	24 [610]	18 [457]	9 [229]	24 [610]	6 [152]	10-3/8 [264]	8-3/8 [213]	13-7/8 [352]	2 -1/2 [64]	21 [533]
16	10 x 8 [254 x 203]	42 [1067]	44 [1118]	44 [1118]	24 [610]	18 [457]	9 [229]	30 [762]	7 [178]	11-1/2 [292]	10-5/8 [270]	16-3/4 [425]	2 -1/2 [64]	21 [533]
20	10 x 8 [254 x 203]	51 [1295]	50 [1270]	50 [1270]	30 [762]	21 [533]	12 [305]	36 [914]	7 [178]	11-1/2 [292]	10-5/8 [270]	19-3/4 [502]	2 -1/2 [64]	21 [533]
30	10 x 8 [254 x 203]	51 [1295]	59 [1499]	56 [1422]	30 [762]	21 [533]	12 [305]	45 [1143]	7 [178]	11-1/2 [292]	10-5/8 [270]	24-1/4 [629]	10 [254]	30 [762]
40	10 x 8 [254 x 203]	54 [1372]	68 [1727]	59 [1499]	30 [762]	24 [610]	15 [381]	48 [1219]	10 [254]	11-1/2 [292]	10-5/8 [270]	28-3/4 [730]	10 [254]	30 [762]