

KBHD Arr. 3

DIRECT DRIVE BLOWER COIL UNIT
DISCHARGE ARG. 3

JOB NAME _____
ENGINEER _____
CONTRACTOR _____
TAG _____

SUBMITTAL SHEET

NOTES:

1. All dimensions are in Inches [millimeters]. All dimensions are $\pm 1/4"$ [6mm]. Metric values are soft conversion.
2. Right hand unit shown, Left hand unit opposite. Motor/drive location may be specified Left or Right Hand. Standard control enclosure location matches motor/drive position.
3. Provide sufficient clearance to permit access to controls and comply with applicable codes and ordinances.
4. See drawing BCS-KBOD-ACFR0 for filter rack details.
5. Base rail is optional on the base unit. See drawing BCS-KBOD-ACEB0. Base rails must be used with mixing box.
6. See coil connection detail drawings for coil connection sizes and locations.

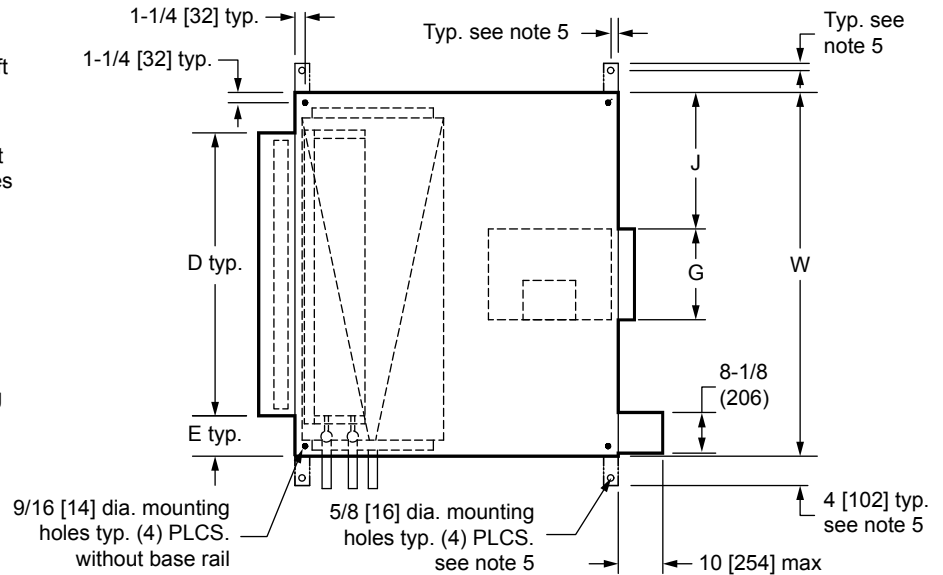

TOP VIEW

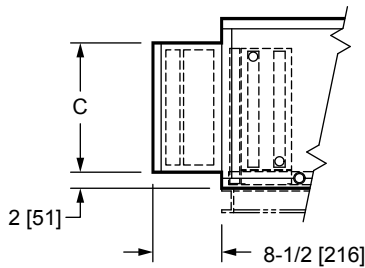

High Efficiency Filter Rack

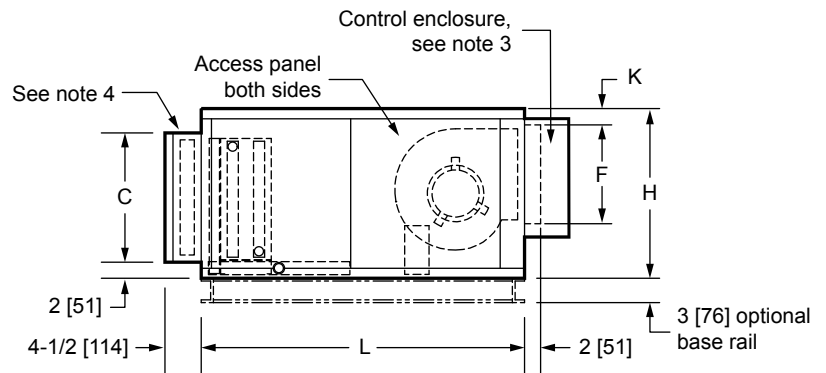

Standard Filter Rack

SIDE VIEW

DIMENSIONS

UNIT SIZE	FAN SIZE	L	W	H	C	D	E	F	G	J	K
08	9 x 6 [229 x 152]	40 [1016]	30 [762]	21 [533]	16 [406]	20 [508]	5 [127]	10 3/8 [264]	8 3/8 [213]	10 7/8 [276]	2 [51]
12	9 x 6 [229 x 152]	40 [1016]	36 [914]	21 [533]	16 [406]	25 [635]	5 1/2 [140]	10 3/8 [264]	8 3/8 [213]	13 7/8 [352]	2 [51]
16	10 x 8 [254 x 203]	40 [1016]	44 [1118]	21 [533]	16 [406]	39 1/2 [1003]	2 1/4 [57]	11 1/2 [292]	10 5/8 [270]	16 5/8 [422]	2 [51]
20	10 x 8 [254 x 203]	40 [1016]	50 [1270]	22 1/2 [572]	16 [406]	44 1/2 [1130]	2 3/4 [70]	11 1/2 [292]	10 5/8 [270]	19 5/8 [498]	3 1/2 [89]
30	10 x 8 [254 x 203]	46 [1168]	59 [1499]	30 [762]	25 [635]	51 [1295]	4 [102]	11 1/2 [292]	10 5/8 [270]	24 1/4 [616]	9 7/8 [251]
40	10 x 8 [254 x 203]	46 [1168]	68 [1727]	30 [762]	25 [635]	59 [1499]	4 1/2 [114]	11 1/2 [292]	10 5/8 [270]	28 5/8 [727]	9 7/8 [251]