

KLPS-D Unit with Hot Water Heat Dimensional Information

KLPS-D UNIT WITH HOT WATER HEAT, INLET, PLAN, AND DISCHARGE VIEWS

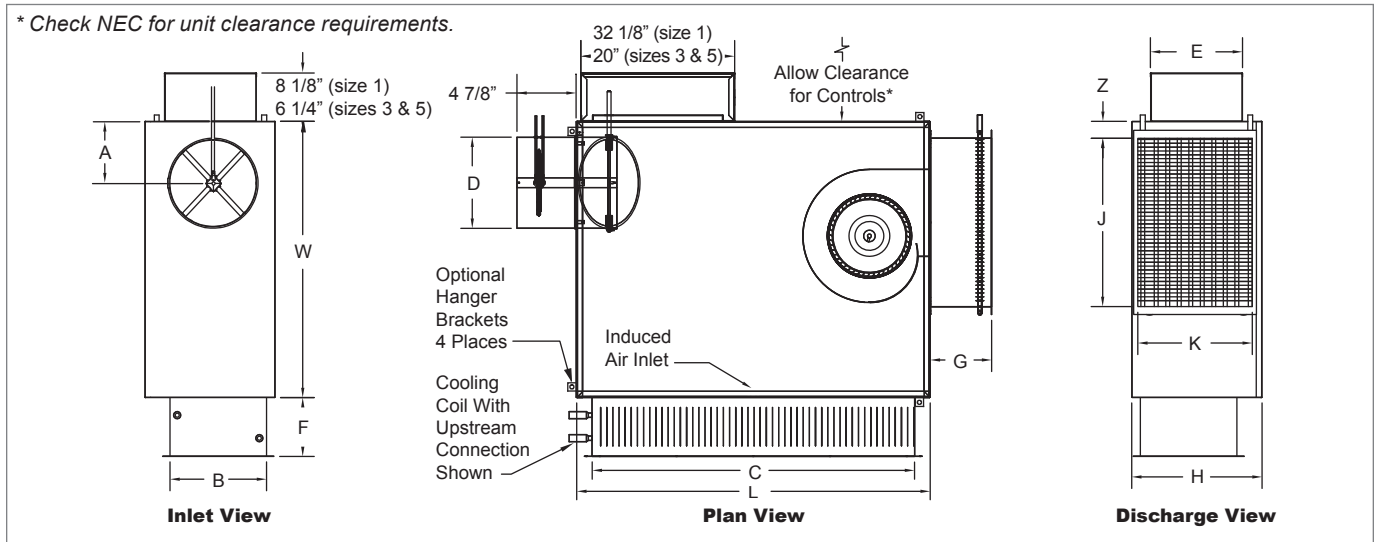

KLPS-D UNIT WITH HOT WATER HEAT, DIMENSIONAL DETAILS

Unit Size	ECM HP	L	W	H	Cooling Coil			Discharge			F			G	
					B	C	E	J	K	Z	2 Row	4 Row	6 Row	1 Row	2 Row
1	1/3	48"	32"	8 5/8"	7 1/2"	36"	8 1/8"	20 1/2"	7 5/8"	1 1/2"	7 7/8"	7 7/8"	10"	9 1/2"	9 1/2"
2	1/3	48"	32"	9 1/2"	7 1/2"	36"	8 1/8"	20 1/2"	7 5/8"	1 1/2"	7 7/8"	7 7/8"	10"	9 1/2"	9 1/2"
3	1/3	40"	26"	11"	8 3/4"	36"	9 5/8"	21 1/8"	8 3/4"	1"	7 7/8"	7 7/8"	10"	9 1/2"	9 1/2"
5	1/2	46"	36"	17"	12 1/2"	42"	12"	22"	15"	2 1/4"	7 7/8"	7 7/8"	10"	8"	9 3/16"

Unit Size	1				2				3				5				
Inlet Size	04	05	06	07	04	05	06	07	04	05	06	07	08	06	07	08	10
A	5"	5"	5"	5"	5"	5"	5"	5"	5"	6"	5"	6"	5"	5"	6"	6"	7"
D	3 7/8"	4 7/8"	5 7/8"	6 7/8"	3 7/8"	4 7/8"	5 7/8"	6 7/8"	3 7/8"	4 7/8"	5 7/8"	6 7/8"	7 7/8"	5 7/8"	6 7/8"	7 7/8"	9 7/8"

NOTE: Left-hand base unit with electronic control enclosure shown; right-hand is available.

KLPS-D Unit with Hot Water Heat Features & Options

STANDARD FEATURES

- 20 gage galvanized steel casing construction.
- Available in unit sizes 1, 2, 3, and 5.
- Control enclosure for electronic components.
- 1/2" thick, dual density fiberglass insulation that meets NFPA 90A and UL 181 safety requirements.
- [120, 208/240, or 277 volt, single-voltage] ECM motor.
- Manual or remote adjustable speed controller.
- Removable bottom panel allows easy access to all internal components for maintenance.
- Four quadrant, center averaging airflow sensor.
- Flanged discharge connection on hot water coil.
- Includes 24 volt control transformer.
- Sensible Cooling Coil factory installed on induced air inlet with drip tray.
- Construction type air filter, two per unit, unit size 1 (18 7/8"x7 1/2"x1"), unit size 2 (18 7/8"x8 3/8"x1"), unit size 3 (18 1/2"x10"x1"), unit size 5 (22"x14 1/2"x1").
- ETL listed; adherence to UL 1995 and CSA C22.2 No. 236.95.

OPTIONAL FEATURES

- Liners: 1/2" or 1" Cellular insulation, 1/2" or 1" Foil encapsulated fiberglass insulation, Sterilwall, Perforated doublewall, 1" Dual density fiberglass. *NOTE: 1" thick liner options are available on unit size 5 only.*
- Linear averaging airflow sensor.
- Left-hand or right-hand control enclosure.
- Left-hand or right-hand hot water coil connection.
- Upstream or downstream cooling coil connection.
- Motor toggle disconnect switch.
- Motor fusing.
- MERV 8 air filter, two per unit, unit size 1 (18 7/8"x7 1/2"x1"), unit size 2 (18 7/8"x8 3/8"x1"), unit size 3 (18 1/2"x10"x1"), and unit size 5 (22"x14 1/2"x1").
- Dust tight control enclosure.
- Hanger brackets.
- Dual access panels with optional Cam locks.