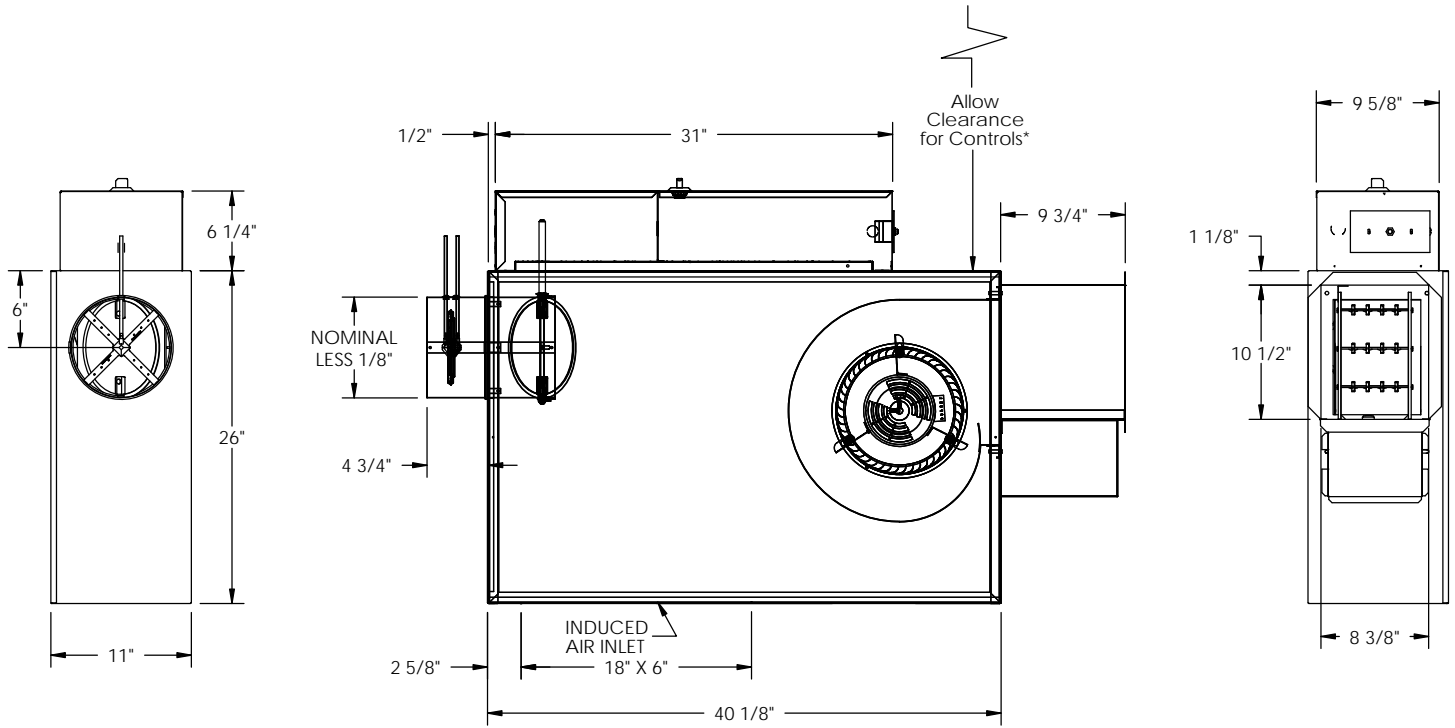

KLPS Unit 3
Electric Heat with Electronic Controls
SUBMITTAL SHEET

Unit Size	Inlet Size
3	08"
3	10"

INLET VIEW
PLAN VIEW - LEFT HAND UNIT
DISCHARGE VIEW
STANDARD FEATURES:

- 20GA. Galvanized Steel Construction
- Steel Control Enclosure for Electronic Components
- 1/2" Thick Dual Density Fiberglass Insulation Meeting NFPA 90A and UL181 Safety Requirements
- 1/4 HP Single Speed, Single Phase, Permanently Lubricated PSC Motor
 - 120V 208/240V 277V
- Field Adjustable Speed Controller
- Bottom Access Panel for Service
- 4 Quadrant, Center Averaging Inlet Flow Sensor
- Factory Supplied 24 Volt Control Transformer for Electronic Controls
- ETL Listed
- Performance Data per AHRI Standard 880
- Variety of Direct Digital or Analog Electronic Control Packages Available

*Check NEC for Unit Clearance Requirements

OPTIONAL FEATURES:

- 1/3 ECM Motor with Permanently Lubricated Ball Bearings and Constant Airflow Program
- Manual Control 0-10Vdc Remote Control
- 2-10Vdc Remote Control
- 120V 208/240V 277V
- Liners
 - 1/2" Cellular Insulation No Liner
 - 1/2" Foil Encapsulated Fiberglass Insulation
 - Solid Metal Liner with 1/2" Dual Density Fiberglass
 - Perforated Metal Liner with 1/2" Dual Density Fiberglass
- Construction Type Air Filters – 19" x 8 5/8" x 1"
- Merv Type Air Filters – 19" x 8 5/8" x 1"
- Linear Averaging Inlet Flow Sensor
- LineaHeat Controlled SSR Heat
 - Discharge Temperature Sensor
- 24VAC SSR Manual Reset Cutoff
- Left Hand Controls Right Hand Controls
- Dust Tight Control Enclosure Motor Fusing
- Hanger Brackets Chicago Code
- Door Interlocking Disconnect Switch:
 - Non-Fused Non-Fused
- Dual Access Panels for Service
 - Cam-Locks (Dual Access Panel Only)