

KLPS

Introduction: KLPS

The KLPS low profile series fan-powered induction terminals are designed to maintain optimum temperatures in the conditioned zone through economical recirculation of plenum return air and accurate control of primary air (cooling) to the zone.

The KLPS low profile fan powered terminal units offer excellent performance and affordability in a compact unit with optimum physical dimensions for buildings where ceiling plenum space is limited. There are three different heights to accommodate every application. The size 1 ultra low profile unit is only 8 5/8" tall making it the most compact fan terminal unit available on the market. The size 2 ultra low profile unit is slightly taller, at 9 1/2", but delivers higher air capacities. Sizes 3 and 4 low profile units offer a diverse operating range for a unit that is only 11" tall. Lastly, unit size 5, at 17", is for applications that will accommodate a slightly larger unit.

The Model KLPS is designed to sustain optimum occupant comfort levels by maintaining a constant supply of air to the conditioned zone. The KLPS recirculation fan draws cold air from the primary air duct and warm air from the return plenum in varying amounts to satisfy zone temperature requirements. Warm air and cold air blend in the unit fan before entering the discharge plenum. Optional heating coils may be used for additional terminal heating requirements. Primary air is modulated with direct digital, analog or pneumatic pressure independent type controls.

MODEL

KLPS - Low Profile, Series Fan Powered Terminal Unit

FEATURES

- Unit size 1: Ultra low profile at only 8 5/8" tall.
- Unit size 2: Ultra low profile at only 9 1/2" tall.
- Unit sizes 3 & 4: Only 11" high to accommodate installation in low height ceiling plenum spaces.
- Unit size 5: Only 17" high for extra capacity applications.
- Airflow capacities: Range up to 1970 CFM for the KLPS to allow airflow control for commercial applications.
- Heavy gage galvanized steel casing for unit strength and product durability.
- Several casing liner options provide quiet and clean operation.
- Fully removable, bottom access panel included with each unit for easy access to all internal components.
- Control enclosure located on left-hand or right-hand side for easier installation.
- Single point electrical connection minimizes number of ceiling plenum electrical connections.
- Recirculation multi-voltage fan motors are quiet, reliable, and permanently lubricated; energy efficient ECM motors are available.
- Electronic speed control (SCR) allows field adjustable fan airflow.
- Isolated motor/blower assembly limits casing acoustical transmission.
- ETL listings are under UL 1995 electrical safety.
- AHRI listings are certified in accordance with AHRI standard 880 testing standard.
- External filter option allows quick and easy access for routine replacement.
- Pneumatic, analog, and digital controls may be customized for many building systems. BACnet/BMS compatible digital controls can be provided by Krueger.
- Auxiliary heat offers a wide range of options, including electric and hot water heat.
- LineaHeat solid state electronic proportional control of electric heat is available with or without leaving air temperature control.
- AC solid state relays offer silent operation for staged electric heat.
- Revit models are available at www.krueger-hvac.com/revit.

KLPS Unit Capacities
KLPS, UNIT CAPACITIES

		KLPS with PSC Motor							
Unit Size	Inlet Size	Primary Airflow		Fan Airflow		Motor HP	Motor Amps		
		Max.	Min.	Max.	Min.		120V	208/240V	277V
3	8	920	160 or 0	1075	460	1/4	5.8	2.6	2.2
	10	1075	250 or 0						
4	10	1425	250 or 0	1650	805	(2)1/6	6.9	3.7	2.7
	8x14	1650	360 or 0						
5	10	1425	250 or 0	1970	840	1/2	8.4	4.2	3.7
	12	1970	360 or 0						
	14	1970	480 or 0						

		KLPS with ECM Motor							
Unit Size	Inlet Size	Primary Airflow		Fan Airflow		Motor HP	Motor Amps		
		Max.	Min.	Max.	Min.		120V	208/240V	277V
1	4	230	40 or 0	850	125	1/3	5.0	3.3	2.6
	5	320	60 or 0						
	6	515	90 or 0						
	7	700	120 or 0						
2	6	515	90 or 0	925	140	1/3	5.0	3.3	2.6
	8	920	160 or 0						
3	6	515	90 or 0	1125	170	1/3	5.0	3.3	2.6
	8	920	160 or 0						
	10	1100	250 or 0						
4	10	1430	250 or 0	1900	285	(2)1/3	10.0	6.6	5.2
	8x14	1900	360 or 0						
5	8	920	160 or 0	1790	265	1/2	7.7	5.0	4.1
	10	1430	250 or 0						
	12	1745	360 or 0						
	14	1745	480 or 0						

NOTES: KLPS maximum primary airflow (CFM) is based on 1.00" WG differential pressure signal from inlet airflow sensor until the value reaches maximum fan CFM for that unit size. A properly balanced unit will be set so the maximum primary CFM is never greater than the fan CFM. Minimum recommended airflow (CFM) is based on 0.03" WG differential pressure of the inlet airflow sensor, or 0 CFM. 0.03" WG is equal to 15%–20% of the nominal flow rating of the terminal. Less than 15%–20% may result in greater than +/-5% control of box flow. Maximum/minimum fan airflow (CFM) is based on 0.10"/0.60" WG external downstream static pressure. See page B2-98 and B2-99 for complete fan curves. KLPS size 4 motor amps includes amperage for two motors.

KLPS Damper Leakage
KLPS, DAMPER LEAKAGE DETAIL

Inlet Size	Damper Leakage		
	1.5" WG CFM	3.0" WG CFM	6.0" WG CFM
4	4	5	7
5	4	5	7
6	4	5	7
7	4	5	7
8	4	5	7
10	4	5	7
12	4	5	7
14	4	6	8

NOTES: Damper leakage is measured with the damper fully closed using an actuator. A precision low flow orifice is used upstream of the unit to measure the leakage rate as a function of the measured upstream static pressure. Leakage testing conducted in accordance with ASHRAE 130-2008.

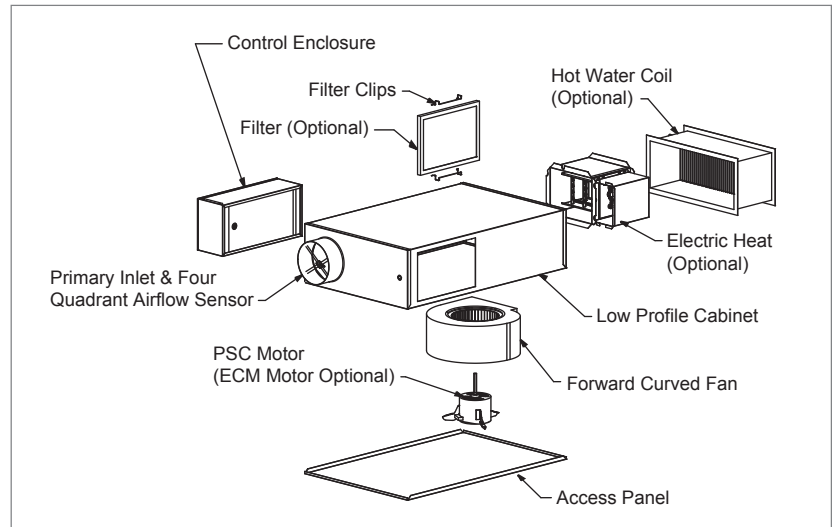
KLPS Exploded View
KLPS, EXPLODED VIEW

KLPS Product Description**CASING**

- All KLPS unit casing panels are constructed of 20 gage galvanized steel.
- Removable bottom panel allows easy access to all internal components.

INLET COLLARS

- All round, 20 gage inlet collars accommodate standard spiral and flex duct sizes. Size 4 units also offer an 8" x 14" rectangular inlet.
- The primary air inlet is located on either the left -hand or right-hand side of the unit inlet panel of KLPS unit, size 1, 2, 3, and 5. The primary air inlet is the center of the KLPS unit, size 4. (Hand is determined by looking at the unit in the direction of airflow with the unit in the installed position.)

OUTLET CONNECTIONS

- All outlet connections are rectangular and require a flanged duct connection.

DAMPER ASSEMBLY

- All unit sizes on the KLPS with exception the rectangle inlet option on unit size 4, utilize a round volume control damper. The unit size 4 with 8" x 14" inlet on KLPS and KLPP have a rectangular volume control damper.
- All damper assemblies are equipped with a solid shaft that rotates in self lubricating Delrin® bearings.
- Damper blade incorporates a flexible gasket for tight airflow shutoff and operates over a full 90 degree rotation.
- The damper position is marked by an arrow embossment on the end of the damper shaft.

INDUCED AIR INLET

- Induced air inlet filters (construction type or MERV 8) are available. These filters are typically used for job start-up and are provided with clip frames for easy filter replacement.

CASING LINERS

All liners are attached to the unit casing with both adhesive and weld pins to ensure long term durability (excludes Sterilwall and Perforated Doublewall). The standard liner option is 1/2" thick, 1 1/2 lb. dual density fiberglass insulation that meets UL 181 and NFPA 90A.

- **(Optional)** Cellular Insulation: 1/2" or 1" (KLPS size 5 only) thick, 1 1/2 lb. density, smooth surface, polyolefin, closed-cell foam insulation for fiber free application. Cellular insulation meets UL 181 and NFPA 90A and does not support mold or bacteria growth.
- **(Optional)** Sterilwall Insulation: 1/2", 1 1/2 lb. dual density fiberglass insulation that meets UL 181 and NFPA 90A, enclosed between the unit casing and a non-perforated internal sheet metal cover extending over the fiberglass insulation, as well as covering the liner cut edges.
- **(Optional)** Perforated Doublewall Insulation: 1/2", 1 1/2 lb. dual density fiberglass insulation that meets UL 181 and NFPA 90A, enclosed between the unit casing and a perforated internal sheet metal cover extending over the fiberglass insulation, as well as covering the liner cut edges.
- **(Optional)** Foil Encapsulated Insulation: Foil reinforced, wrapped edges, 1/2" or 1" (KLPS size 5 only) thick, 1 1/2 lb.

density fiberglass insulation that meets UL 181 and NFPA 90A.

- **(Optional - KLPS Unit Size 5 Only)** Steriliner Insulation: 13/16" thick, 4 lb. density, rigid board insulation with fiber reinforced foil covering insulation fibers that meets UL 181 and NFPA 90A. Liner shall be attached to unit casing by adhesive and weld pins with foil tape sealing the insulation cut edges.
- **(Optional - KLPS Unit Size 5 Only)** 1" Thick Insulation: 1" thick, 1 1/2 lb. dual density fiberglass insulation that meets UL 181 and NFPA 90A.
- **(Optional - KLPS Unit Size 5 Only)** No Liner: No internal insulation liner.

AIRFLOW SENSOR

- All units are equipped with a factory installed inlet airflow sensor device.
- K4 LineaCross: A four-quadrant, multi-point, center averaging airflow sensor.
- **(Optional)** A linear, multi-point, velocity averaging airflow sensor with an amplified signal.
- Balancing taps are provided for easy airflow verification.

FAN MOTORS

- Fan motors are single-voltage (120,208/240 and 277) single phase, permanent split capacitor (PSC) type.
- **(Optional)** [120, 208/240, or 277 volt, single-phase] ECM (electronically commutated motor) fan motor is available.
- Units equipped with [120, 208/240 or 277 volt, single-phase] electric heat have fan motors wired with the same line voltage. Units with [208 volt, three-phase, three-wire] electric heat utilize 208/240 volt fan motors. Units with [480 volt, three-phase, four-wire] heat are equipped with 277 volt fan motors.
- Quick electrical disconnects are provided on the motor wiring.
- A motor disconnect switch is available. (This option is not available if the unit is equipped with electric heat including the door locking disconnect option.)
- Motor fusing is available.

FAN SPEED CONTROL

- All units with PSC motors are equipped with SCR fan speed controller capable of reducing fan output by as much as 50 to 55%.
- All units with optional ECM motors include either a manual or remote adjustable speed controller. The manual adjustable speed controller features a digital display that alternates between the RPM of the motor and percentage of flow and can be set and adjusted in the field. The remote adjustable speed controller communicates with a DDC controller to remotely set and/or adjust the fan speed using either a 0-10 VDC or 2-10 VDC signal and provides a manual override capability to set and/or adjust the fan speed in the field.

CONTROLS

- Pneumatic, analog or direct digital control types are available. Digital controls can be provided by others or Krueger for factory mounting. A "no control" unit is also available for field mounting of direct digital controls.

KLPS Product Description

HOT WATER HEAT

- One or two row coils are constructed of 10 aluminum fins per inch with 1/2" O.D. sweat type, left-hand or right hand, tubing connections. The coil tubing is water leakage tested to 400 psig.

SENSIBLE COOLING COIL

- The KLPS-D offers two, four, or six row coils are constructed of 10 aluminum fins per inch with 7/8" O.D. sweat type, upstream or downstream tubing connections. The coil tubing is water leakage tested to 400 psig.

ELECTRIC HEAT

- Heaters are UL listed and are constructed of 20 gage galvanized steel.
- Available combinations are:
 - [120, 208/240, or 277 volt, single-phase]
 - [208 volt, three-phase, three-wire]
 - [480 volt, three-phase, four-wire]
- See fan motor description for electric heat/fan motor combinations.
- Standard heaters are equipped with automatic reset thermal cutout, magnetic contactors, airflow proving switch, and 80/20 Ni-Cr heating elements.
- Electric heater options include fused or non-fused door interlocking disconnect switch, fuse-block, manual reset cutout, and dust tight enclosure construction.
- AC solid state relays offer silent operation for staged electric heat.
- LineaHeat solid state electronic proportional control of electric heat is available with or without leaving air temperature control. See Krueger's Terminal Unit Engineering section for additional information.

CONTROL TRANSFORMERS

- Units with and without electric heat include a factory supplied, mounted and wired control transformer mounted inside the electric heat enclosure for electronic control applications.

LABELS

- Label information adhered to each unit includes model name, unit size, configuration code, airflow (CFM), balancing chart, tagging data, electrical ratings, removal of fan protection packing material information, and all required agency listings.

PACKAGING

- Units are palletized. Each pallet of units is banded and stretch wrapped with cellophane.

KLPS Base Unit Dimensional Information

KLPS BASE UNIT, INLET, PLAN, AND DISCHARGE VIEWS (UNIT SIZES 1, 2, 3, & 5)

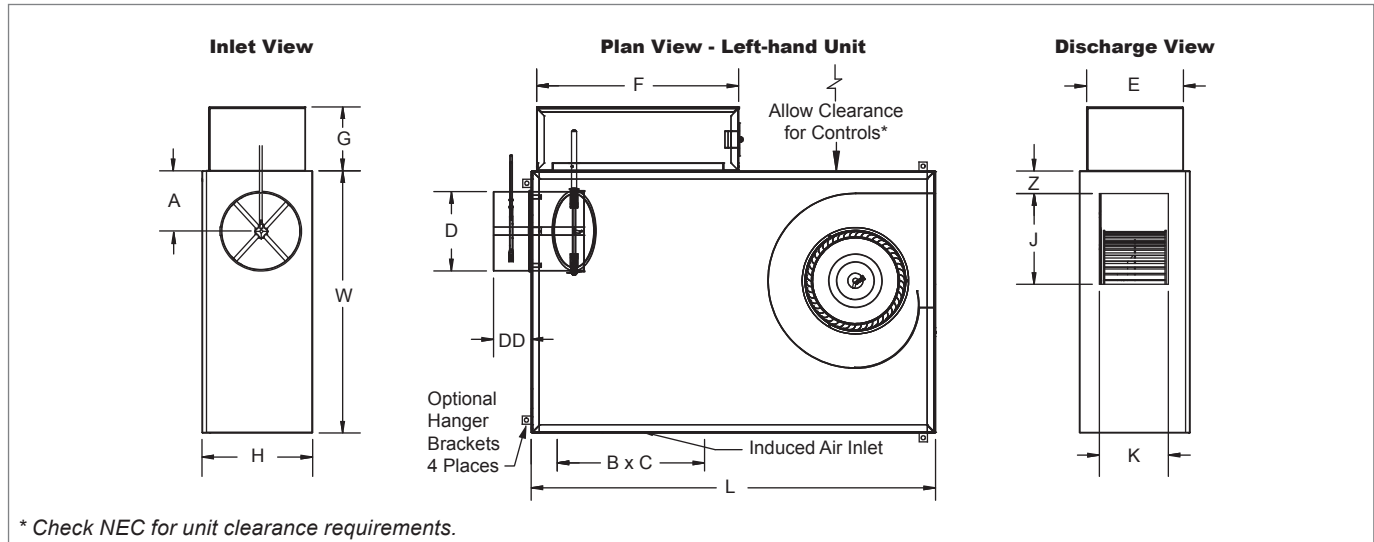

* Check NEC for unit clearance requirements.

KLPS BASE UNIT, DIMENSIONAL DETAILS (UNIT SIZES 1, 2, 3, & 5)

Unit Size	Inlet Size	PSC Motor	ECM Motor	L	W	H	A	Induced Air Inlet		D	DD	Control Enclosure			Discharge		Z
		HP	HP					B	C			E	F	G	J	K	
1	04	N/A	1/3	48"	32"	8 5/8"	5"	18"	6 3/4"	3 7/8"	6 7/8"	8 1/8"	32 1/8"	8 1/8"	10"	5 7/8"	2"
	05									4 7/8"	6 7/8"						
	06									5 7/8"	4 7/8"						
	07									6 7/8"	4 7/8"						
2	06	N/A	1/3	48"	32"	9 1/2"	5"	18"	6"	5 7/8"	4 7/8"	8 1/8"	32 1/8"	8 1/8"	10"	5 7/8"	2"
	08						6"			7 7/8"	4 7/8"						
3	08	1/4	1/3	40"	26"	11"	5"	14 5/8"	9"	7 7/8"	4 7/8"	9 5/8"	20"	6 1/4"	9"	6 7/8"	2 1/4"
	10						6"			9 7/8"	4 7/8"						
5	08	1/2	1/2	46"	36"	17"	6"	17"	14"	7 7/8"	4 7/8"	12"	20"	6 1/4"	10"	10 5/8"	6 1/4"
	10						7"			9 7/8"	4 7/8"						
	12						8"			11 7/8"	6 7/8"						
	14						10"			13 7/8"	6 7/8"						

NOTE: Left-hand base unit with electronic control enclosure shown; right-hand is available.

KLPS Base Unit Features & Options

STANDARD FEATURES (UNIT SIZES 1, 2, 3, & 5)

- 20 gage galvanized steel casing construction.
- Available heights for unit size 1 (8 5/8"), unit size 2 (9 1/2"), unit size 3 (11"), and unit size 5 (17").
- Control enclosure for electronic components.
- 1/2" Thick, Dual density fiberglass insulation that meets NFPA 90A and UL 181 safety requirements.
- [120, 208/240, or 277 volt, single-voltage, single-phase, single-speed] permanently lubricated PSC motors. (Unit size 3 and 5 only.)
- Field adjustable fan speed control.
- Removable bottom panel allows easy access to all internal components for maintenance.
- Four quadrant, center averaging airflow sensor.
- Includes 24 volt control transformer.
- ETL listed; adherence to UL 1995 and CSA C22.2 No. 236.95.
- AHRI certified sound ratings.

OPTIONAL FEATURES (UNIT SIZES 1, 2, 3, & 5)

- Liners: 1/2" or 1" Cellular insulation, 1/2" or 1" Foil encapsulated fiberglass insulation, Sterilwall, or Perforated doublewall. NOTE: 1" Thick liner options available on unit size 5 only.
- Linear averaging airflow sensor.
- [120, 208/240, or 277 volt, single-voltage] ECM motor with manual or remote adjustable speed controller.
- Left-hand or right-hand control enclosure.
- Motor toggle disconnect switch.
- Motor fusing.
- Induced air filter, construction type; unit size 1 (18 7/8"x7 1/2"x1"), unit size 2 (19"x8 5/8"x1"), unit size 3 (17"x11"x1"), and unit size 5 (19"x16 1/2"x1").
- Dust tight control enclosure.
- Hanger brackets.
- Dual access panels with optional Cam locks.

FAN POWERED TERMINAL UNITS

KLPS

© KRUEGER 2012

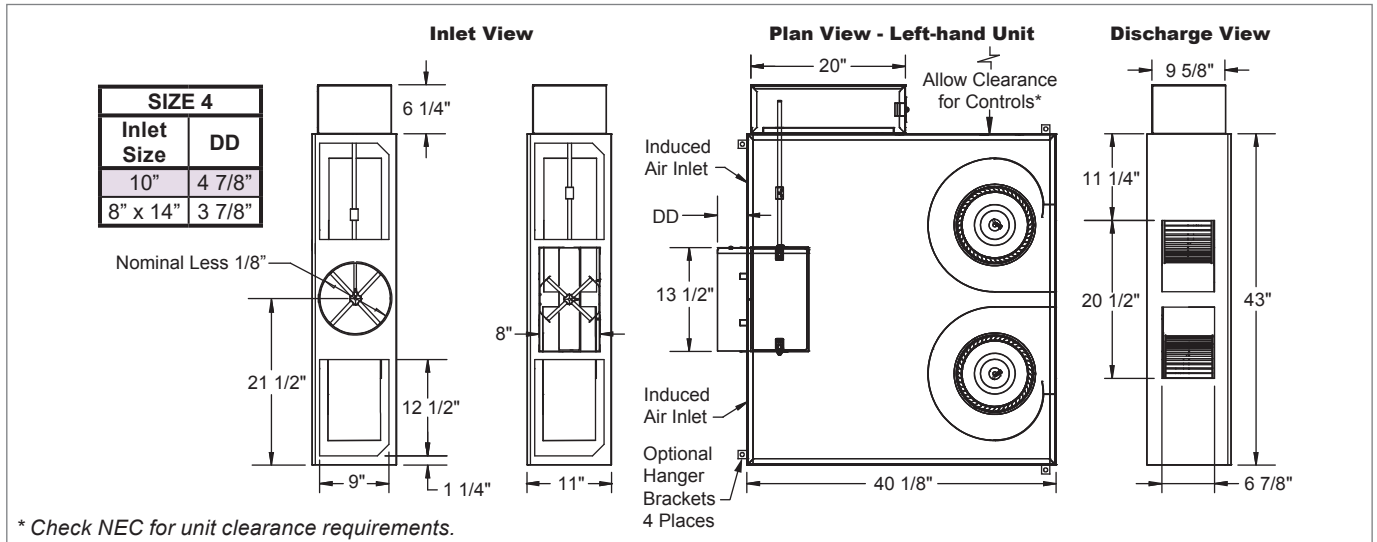
KLPS Base Unit Dimensional Information
KLPS BASE UNIT, INLET, PLAN, AND DISCHARGE VIEWS (UNIT SIZE 4)

NOTE: Left-hand base unit with electronic control enclosure shown; right-hand is available.

KLPS Base Unit Features & Options
STANDARD FEATURES (UNIT SIZE 4)

- 20 gage galvanized steel casing construction.
- Height is 11".
- Control enclosure for electronic components.
- 1/2" Thick, Dual density fiberglass insulation that meets NFPA 90A and UL 181 safety requirements.
- [120, 208/240, or 277 volt, single-voltage, single-phase, single-speed] permanently lubricated PSC motors.
- Field adjustable fan speed control.
- Removable bottom panel allows easy access to all internal components for maintenance.
- Four quadrant, center averaging airflow sensor.
- Includes 24 volt control transformer.
- ETL listed; adherence to UL 1995 and CSA C22.2 No. 236.95.
- AHRI certified sound ratings.

OPTIONAL FEATURES (UNIT SIZE 4)

- Liners: 1/2" Cellular insulation, 1/2" Foil encapsulated fiberglass insulation, Sterilwall, or Perforated doublewall.
- Linear averaging airflow sensor.
- [120, 208/240, or 277 volt, single-voltage] ECM motor with manual or remote adjustable speed controller.
- Left-hand or right-hand control enclosure.
- Motor toggle disconnect switch.
- Motor fusing.
- Induced air filter, construction type (15"x11"x1"), quantity 2.
- Dust tight control enclosure.
- Hanger brackets.
- Dual access panels with optional Cam locks, quantity 2.

KLPS Unit with Hot Water Heat Dimensional Information

KLPS UNIT WITH HOT WATER HEAT, INLET, PLAN, AND DISCHARGE VIEWS (UNIT SIZES 1, 2, 3, & 5)

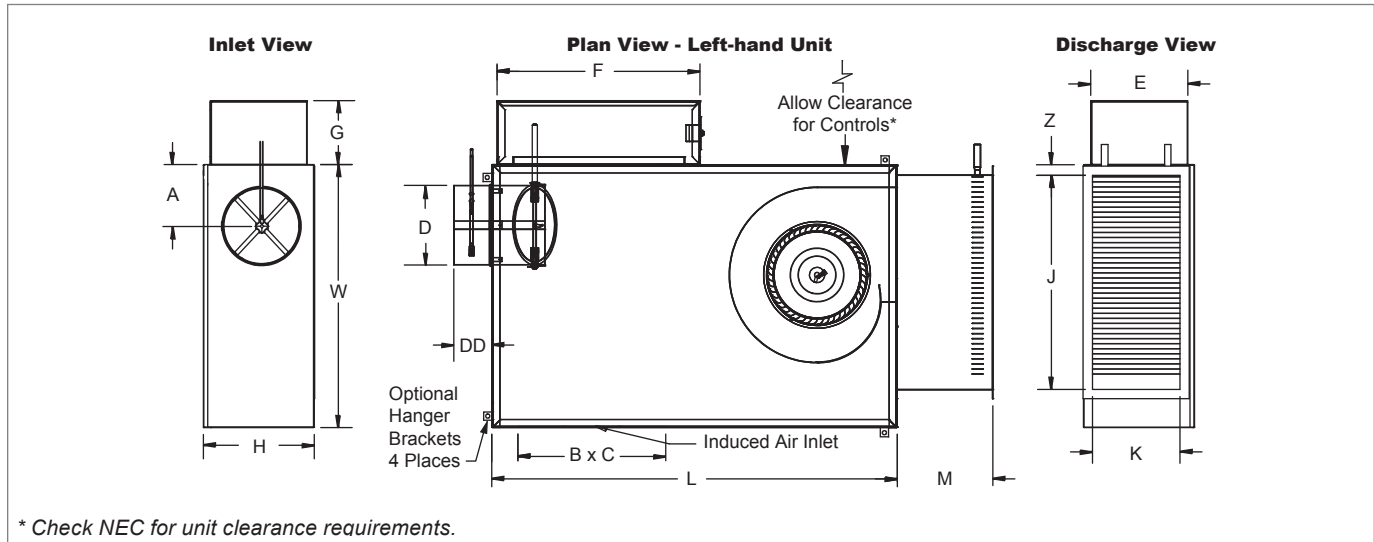

KLPS BASE UNIT WITH HOT WATER HEAT, DIMENSIONAL DETAILS (UNIT SIZES 1, 2, 3, & 5)

Unit Size	Inlet Size	PSC Motor	ECM Motor	L	W	H	A	Induced Air Inlet		D	DD	Control Enclosure			Discharge		M	Z
		HP	HP					B	C			E	F	G	J	K		
1	04	N/A	1/3	48"	32"	8 5/8"	5"	18"	6 3/4"	3 7/8"	6 7/8"	8 1/8"	32 1/8"	8 1/8"	20 1/2"	7 5/8"	9 1/2"	1 1/2"
	05									4 7/8"	6 7/8"							
	06									5 7/8"	4 7/8"							
	07									6 7/8"	4 7/8"							
2	06	N/A	1/3	48"	32"	9 1/2"	5"	18"	6"	5 7/8"	4 7/8"	8 1/8"	32 1/8"	8 1/8"	20 1/2"	7 5/8"	9 1/2"	1 1/2"
	08						6"			7 7/8"	4 7/8"							
3	08	1/4	1/3	40"	26"	11"	5"	14 5/8"	9"	7 7/8"	4 7/8"	9 5/8"	20"	6 1/4"	21 7/8"	8 3/4"	9 1/2"	1"
	10						6"			9 7/8"	4 7/8"							
5	08	1/2	1/2	46"	36"	17"	6"	17"	14"	7 7/8"	4 7/8"	12"	20"	6 1/4"	22"	15"	9 3/16"	2 1/4"
	10						7"			9 7/8"	4 7/8"							
	12						8"			11 7/8"	6 7/8"							
	14						10"			13 7/8"	6 7/8"							

NOTE: Left-hand base unit with electronic control enclosure shown; right-hand is available.

KLPS Unit with Hot Water Heat Features & Options

STANDARD FEATURES (UNIT SIZES 1, 2, 3, & 5)

- 20 Gage galvanized steel casing construction.
- Available heights for unit size 1 (8 5/8"), unit size 2 (9 1/2"), unit size 3 (11"), and unit size 5 (17").
- Control enclosure for electronic components.
- 1/2" Thick, Dual density fiberglass insulation that meets NFPA 90A and UL 181 safety requirements.
- [120, 208/240, or 277 volt, single-voltage, single-phase, single-speed] permanently lubricated PSC motors. (Unit size 3 and 5 only.)
- Field adjustable fan speed control.
- Removable bottom panel allows easy access to all internal components for maintenance.
- Flanged discharge connection on hot water coil.
- Four quadrant center averaging airflow sensor.
- Includes 24 volt control transformer.
- ETL listed; adherence to UL 1995 and CSA C22.2 No. 236.95
- AHRI certified sound ratings.

OPTIONAL FEATURES (UNIT SIZES 1, 2, 3, & 5)

- Liners: 1/2" or 1" Cellular insulation, 1/2" or 1" Foil encapsulated fiberglass insulation, Sterilwall, or Perforated doublewall. NOTE: 1" thick liner options are available on unit size 5 only.
- Linear averaging airflow sensor.
- Left-hand or right-hand hot water coil connections.
- Left-hand or right-hand control enclosure.
- [120, 208/240, or 277 volt, single-voltage] ECM motor with manual or remote adjustable speed controller.
- Motor toggle disconnect switch.
- Motor fusing.
- Induced air filter, construction type; unit size 1 (18 7/8"x7 1/2"x1"), unit size 2 (19"x8 5/8"x1"), unit size 3 (17"x11"x1"), and unit size 5 (19"x16 1/2"x1").
- Dust tight control enclosure.
- Hanger brackets.
- Dual access panels with optional Cam locks.

FAN POWERED TERMINAL UNITS

K
L
P
S

© KRUEGER 2012

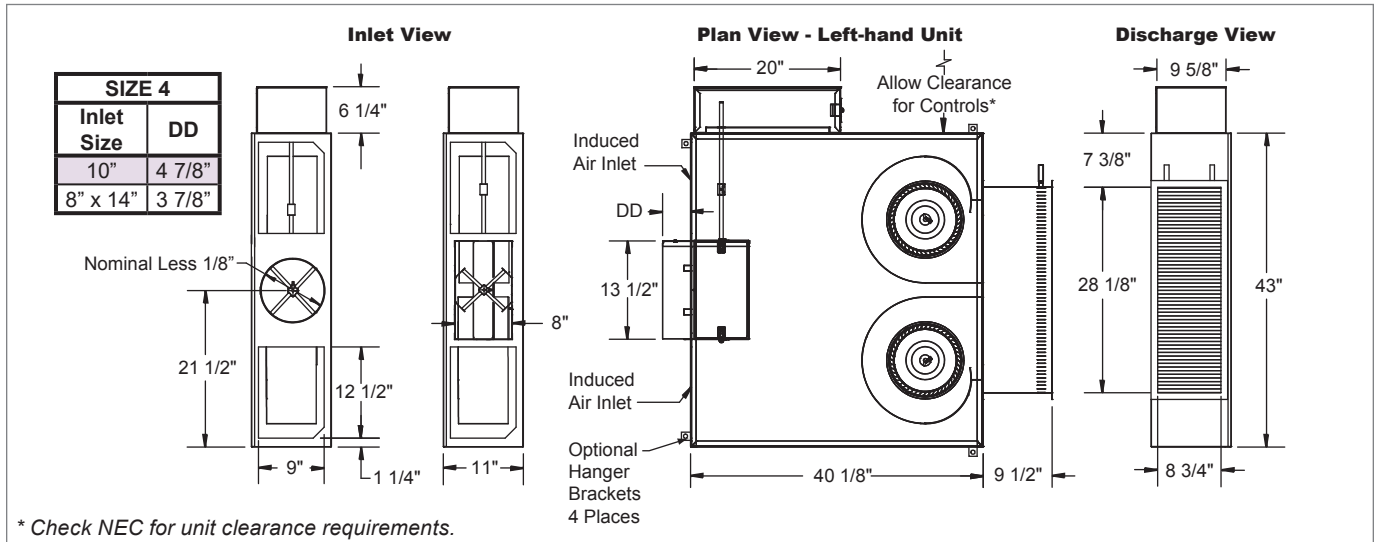
KLPS Unit with Hot Water Heat Dimensional Information
KLPS UNIT WITH HOT WATER HEAT, INLET, PLAN, AND DISCHARGE VIEWS (UNIT SIZE 4)

NOTE: Left-hand base unit with electronic control enclosure shown; right-hand is available.

KLPS Unit with Hot Water Heat Features & Options
STANDARD FEATURES (UNIT SIZE 4)

- 20 Gage galvanized steel casing construction.
- Height is 11".
- Control enclosure for electronic components.
- 1/2" Thick, Dual density fiberglass insulation that meets NFPA 90A and UL 181 safety requirements.
- [120, 208/240, or 277 volt, single-voltage, single-phase, single-speed] permanently lubricated PSC motors.
- Field adjustable fan speed control.
- Removable bottom panel allows easy access to all internal components for maintenance.
- Flanged discharge connection on hot water coil.
- Four quadrant center averaging airflow sensor.
- Includes 24 volt control transformer.
- ETL listed; adherence to UL 1995 and CSA C22.2 No. 236.95
- AHRI certified sound ratings.

OPTIONAL FEATURES (UNIT SIZE 4)

- Liners: 1/2" Cellular insulation, 1/2" Foil encapsulated fiberglass insulation, Sterilwall, or Perforated doublewall.
- Linear averaging airflow sensor.
- Left-hand or right-hand hot water coil connections.
- Left-hand or right-hand control enclosure.
- [120, 208/240, or 277 volt, single-voltage] ECM motor with manual or remote adjustable speed controller.
- Motor toggle disconnect switch.
- Motor fusing.
- Induced air filter, construction type (15"x11"x1"), quantity 2.
- Dust tight control enclosure.
- Hanger brackets.
- Dual access panels with optional Cam locks.

KLPS Hot Water Coil Dimensional Information

KLPS HOT WATER COIL, PLAN AND FRONT VIEWS

FAN POWERED TERMINAL UNITS

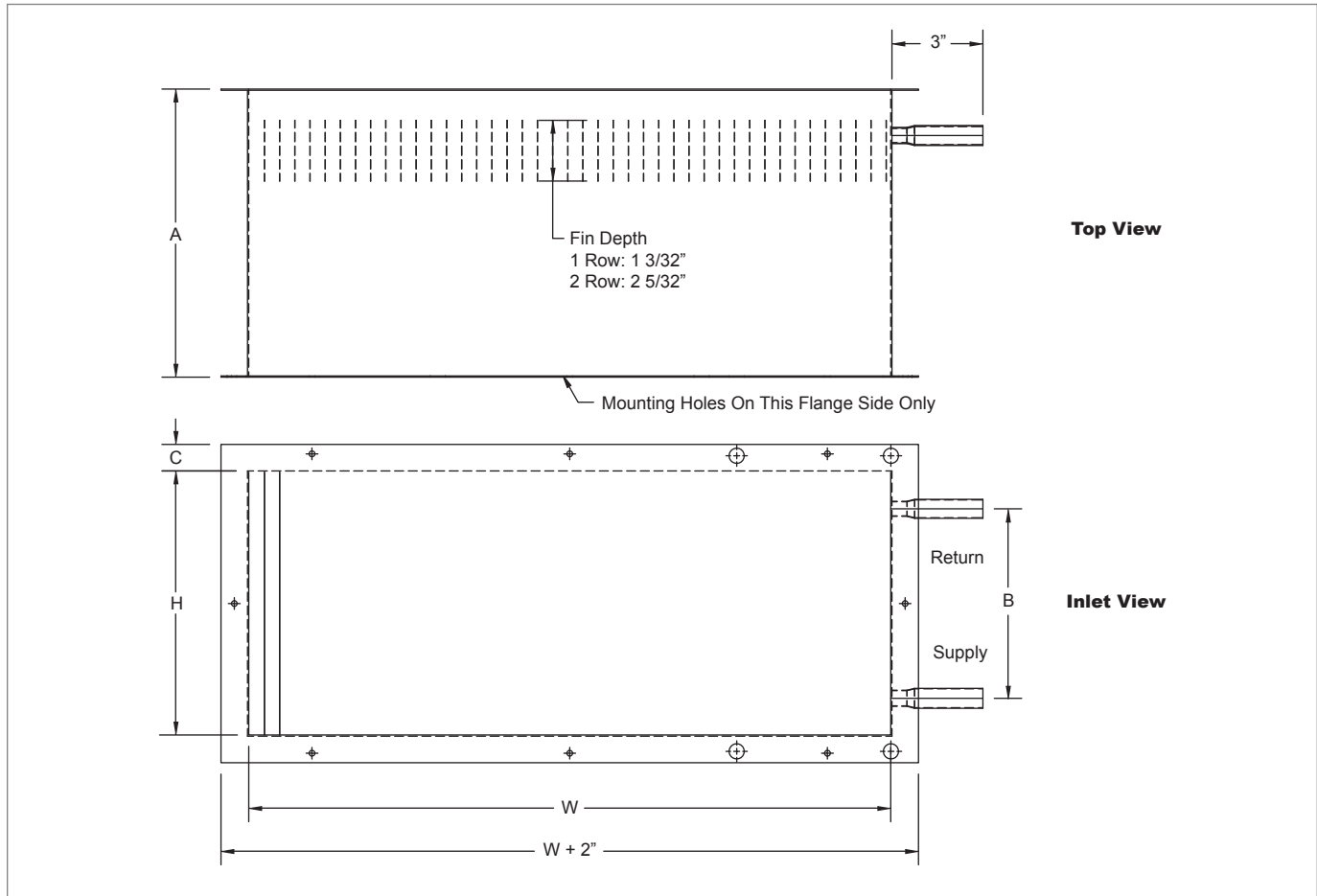

KLPS HOT WATER COIL, DIMENSIONAL DETAILS

Unit Size	Number of Rows	W	H	A	B	C
1, 2	1	20 1/2"	6 5/8"	9 1/2"	4 9/16"	1/2" *
	2					
3	1	21 1/8"	8 3/4"	9 1/2"	6 1/4"	7/8"
	2					
4	1	28 1/8"	8 3/4"	9 1/2"	6 1/4"	7/8"
	2					
5	1	22"	15"	8"	14"	1/2"
	2			9 3/16"	13 3/4"	

NOTE: The top and bottom flange on the unit size 1 and 2 hot water coils turn inward.

NOTE:

For hot water performance data tables, visit the Krueger website at www.krueger-hvac.com or download the Krueger selection software to run customized selections. The selection program can provide performance data with different entering air and water conditions as well as show effects of altitude and glycol on the heating performance of the water coil. The selection software also allows selections to be saved in a schedule format that can be imported onto a set of project drawings.

KLPS Hot Water Coil Features & Options

STANDARD FEATURES

- KLPS coils are shipped from the factory attached to the unit discharge.
- Hot water coils are configured for a flanged ductwork connection. Coil section is uninsulated.
- Coils are not for steam applications.
- Contact your Krueger Representative for high capacity or steam coil information.
- Connection Tubing: 1/2" O. D. male solder.
- Coil Casing: 20 gage galvanized steel.
- Coil Tubing: 1/2" O. D. x 0.016" thick copper.
- Coil Fins: 0.0045" thick aluminum, 10 per inch; mechanically bonded to tubing.

KLPS

© KRUEGER 2012

KLPS Unit with Electric Heat Dimensional Information

KLPS UNIT WITH ELECTRIC HEAT, INLET, PLAN, AND DISCHARGE VIEWS (UNIT SIZES 1, 2, 3, & 5)

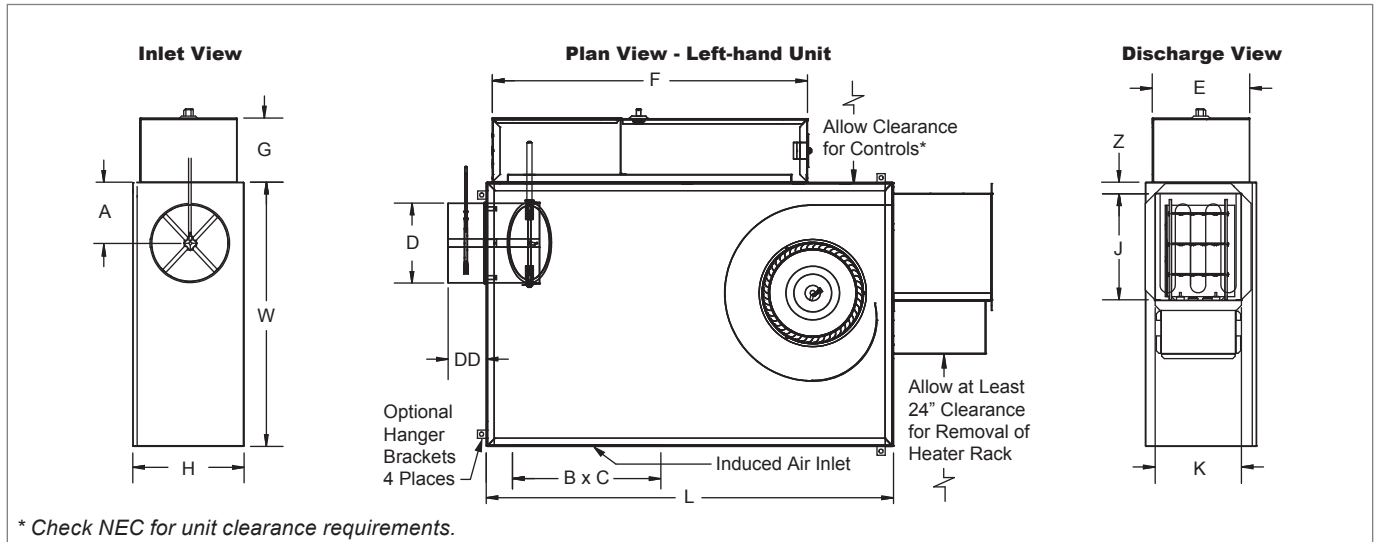

KLPS BASE UNIT WITH ELECTRIC HEAT, DIMENSIONAL DETAILS (UNIT SIZES 1, 2, 3, & 5)

Unit Size	Inlet Size	PSC Motor	ECM Motor	L	W	H	A	Induced Air Inlet		D	DD	Control Enclosure			Discharge		Z
		HP	HP					B	C			E	F	G	J	K	
1	04	N/A	1/3	48"	32"	8 5/8"	5"	18"	6 3/4"	3 7/8"	6 7/8"	8 1/8"	32 1/8"	8 1/8"	10 1/2"	7 3/4"	1 1/8"
	05									4 7/8"	6 7/8"						
	06									5 7/8"	4 7/8"						
	07									6 7/8"	4 7/8"						
2	06	N/A	1/3	48"	32"	9 1/2"	5"	18"	6 3/4"	5 7/8"	4 7/8"	8 1/8"	32 1/8"	8 1/8"	10 1/2"	7 3/4"	1 1/8"
	08						6"			7 7/8"	4 7/8"						
3	08	1/4	1/3	40"	26"	11"	5"	14 5/8"	9"	7 7/8"	4 7/8"	9 5/8"	31"	6 1/4"	10 1/2"	8 1/2"	1 1/8"
	10						6"			9 7/8"	4 7/8"						
5	08	1/2	1/2	46"	36"	17"	6"	17"	14"	7 7/8"	4 7/8"	12"	31"	6 1/4"	14 1/2"	13"	6 1/4"
	10						7"			9 7/8"	4 7/8"						
	12						8"			11 7/8"	6 7/8"						
	14						10"			13 7/8"	6 7/8"						

NOTES: Left-hand base unit with electronic control enclosure shown; right-hand is available. See page B2-97 for electric heat standard features.

KLPS Unit with Electric Heat Features & Options

STANDARD FEATURES (UNIT SIZES 1, 2, 3, & 5)

- 20 Gage galvanized steel casing construction.
- Available heights for unit size 1 (8 5/8"), unit size 2 (9 1/2"), unit size 3 (11"), and unit size 5 (17").
- Control enclosure for electronic components.
- 1/2" Thick, Dual density fiberglass insulation that meets NFPA 90A and UL 181 safety requirements.
- [120, 208/240, or 277 volt, single-voltage, single-phase, single-speed] permanently lubricated PSC motors. (Unit size 3 and 5 only.)
- Field adjustable fan speed control.
- Removable bottom panel allows easy access to all internal components for maintenance.
- Four quadrant, center averaging airflow sensor.
- Flanged discharge connection on electric heat coil.
- Single point electrical connection.
- Includes 24 volt control transformer.
- ETL listed; adherence to UL 1995 and CSA C22.2 No. 236.95.
- AHRI certified sound ratings.

OPTIONAL FEATURES (UNIT SIZES 1, 2, 3, & 5)

- Liners: 1/2" or 1" Cellular insulation, 1/2" or 1" Foil encapsulated fiberglass insulation, Sterilwall, or Perforated doublewall. *NOTE: 1" thick liner options are available on unit size 5 only.*
- Linear averaging airflow sensor.
- [120, 208/240, or 277 volt, single-voltage] ECM motor with manual or remote adjustable speed controller.
- Left-hand or right-hand control enclosure.
- LineaHeat solid state electronic controlled heater with or without leaving air temperature control.
- Fused or non-fused door interlocking disconnect.
- Induced air filter, construction type; unit size 1 (18 7/8"x7 1/2"x1"), unit size 2 (19"x8 5/8"x1"), unit size 3 (17"x11"x1"), and unit size 5 (19"x16 1/2"x1").
- Dual access panels with optional Cam locks.
- Dust tight control enclosure.
- Motor fusing.
- Manual reset cutout.
- Hanger brackets.
- AC solid state relays.
- Fuse-block.

KLPS Unit with Electric Heat Dimensional Information

KLPS UNIT WITH ELECTRIC HEAT, INLET, PLAN, AND DISCHARGE VIEWS (UNIT SIZE 4)

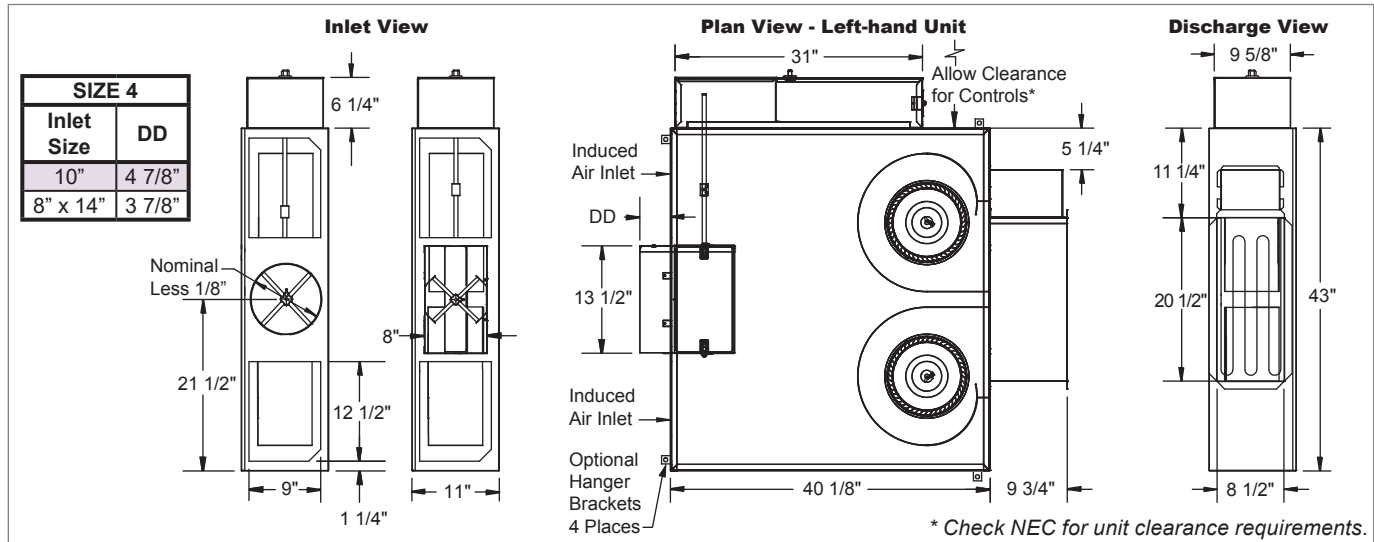

NOTES: Left-hand base unit with electronic control enclosure shown; right-hand is available. See next page for electric heat standard features.

KLPS Unit with Electric Heat Features & Options

STANDARD FEATURES (UNIT SIZE 4)

- 20 Gage galvanized steel casing construction.
- Height is 11".
- Control enclosure for electronic components.
- 1/2" Thick, Dual density fiberglass insulation that meets NFPA 90A and UL 181 safety requirements.
- [120, 208/240, or 277 volt, single-voltage, single-phase, single-speed] permanently lubricated PSC motors.
- Field adjustable fan speed control.
- Removable bottom panel allows easy access to all internal components for maintenance.
- Four quadrant, center averaging airflow sensor.
- Flanged discharge connection on electric heat coil.
- Single point electrical connection.
- Includes 24 volt control transformer.
- ETL listed; adherence to UL 1995 and CSA C22.2 No. 236.95.
- AHRI certified sound ratings.

OPTIONAL FEATURES (UNIT SIZE 4)

- LineaHeat solid state electronic controlled heater with or without leaving air temperature control.
- Liners: 1/2" Cellular insulation, 1/2" Foil encapsulated fiberglass insulation, Sterilwall, or Perforated doublewall.
- Linear averaging airflow sensor.
- [120, 208/240, or 277 volt, single-voltage] ECM motor with manual or remote adjustable speed controller.
- Left-hand or right-hand control enclosure.
- Fused or non-fused door interlocking disconnect.
- Induced air filter, construction type (15"x11"x1").
- Dust tight control enclosure.
- Hanger brackets.
- Motor fusing.
- AC solid state relays.
- Manual reset cutout.
- Fuse-block.
- Dual access panels with optional Cam locks.

FAN POWERED TERMINAL UNITS

KLPS

KLPS Electric Heat Features & Capacities

The kW charts below indicates the maximum and minimum safe limit capacities for each of the KLPS units and has been specifically designed for Krueger fan powered terminals. For safe operation, the electric heater controls are interlocked with the airflow proving switch to allow the heater to energize only after the fan is running. Each terminal unit has been tested by ETL in accordance with UL standards.

ELECTRIC HEAT STANDARD FEATURES

- 20 Gage galvanized steel casing construction.
- Line voltage combinations:
[120, 208/240, or 277 volt, single-phase]
[208 volt, three-phase, three-wire]
[480 volt, three-phase, four-wire]
- NEMA 2 electric heat control enclosure.
- Flanged discharge for field duct connection.
- Single point connection between the heater and the fan motor (see combinations below).
- 80/20 Ni-Cr heating elements.
- Automatic reset thermal cutout.
- Magnetic contactors.
- Positive pressure airflow switch.

NOTE: A minimum of 0.1" w.g. downstream static pressure is required in the duct to ensure proper heater operation.

OPTIONAL HEATER CONTROL

- LineaHeat solid state electronic proportional control of electric heat is available with or without leaving air temperature control. See Krueger's Terminal Unit Engineering section for additional information.
- AC solid state relays offer silent operation for staged electric heat.

SINGLE POINT CONNECTION COMBINATIONS ELECTRIC HEATER/FAN MOTOR

- [120, 208/240 or 277 volt, single-phase] electric heat includes fan motor wired with same line voltage.
- [208 volt, three-phase, three-wire] electric heat utilizes a 208/240 volt, single-phase fan motor.
- [480 volt, three-phase, four-wire] electric heat is equipped with 277 volt, single-phase fan motor.

$$kW = \frac{CFM \times \Delta T (\text{°F})}{3160}$$

CALCULATING ELECTRIC HEATER AMPERES

$$\text{Single Phase Amperes} = \frac{\text{Watts}}{\text{Line Voltage}}$$

$$\text{Three Phase Amperes} = \frac{\text{Watts}}{\text{Line Voltage} \times 1.73}$$

NOTES: When selecting electric heaters, do not exceed 120°F discharge air temperature, per NEC. The ASHRAE Handbook of Fundamentals states that discharge temperatures in excess of 90°F are likely to result in objectionable air temperature stratification in the space. Also, ventilation short circuiting may occur. ASHRAE Standard 62 now limits discharge temperatures to 90°F or increasing the ventilation rate when heating from the ceiling.

KLPS MINIMUM / MAXIMUM KW

			Unit Sizes									
			1		2		3		4		5	
			Min.	Max.	Min.	Max.	Min.	Max.	Min.	Max.	Min.	Max.
1 Phase	120 Volt	1 Stage	0.5	4.5	0.5	4.5	0.5	4.0	0.5	4.0	0.5	4.5
		2 Stage	1.0	4.5	1.0	4.5	1.0	4.0	1.0	4.0	1.0	4.5
		3 Stage	1.5	4.5	1.5	4.5	1.5	4.0	1.5	4.0	1.5	4.5
	208 Volt	1 Stage	0.5	6.0	0.5	6.0	0.5	8.0	0.5	8.0	0.5	9.0
		2 Stage	1.0	6.0	1.0	6.0	1.0	8.0	1.0	8.0	1.0	9.0
		3 Stage	1.5	6.0	1.5	6.0	1.5	8.0	1.5	8.0	1.5	9.0
	240 Volt	1 Stage	1.0	6.0	1.0	6.0	1.0	9.0	0.5	10.0	1.0	10.0
		2 Stage	1.5	6.0	1.5	6.0	1.5	9.0	1.0	10.0	1.5	10.0
		3 Stage	2.0	6.0	2.0	6.0	2.0	9.0	1.5	10.0	2.0	10.0
	277 Volt	1 Stage	1.0	6.0	1.0	6.0	1.0	9.0	0.5	12.0	0.5	12.0
		2 Stage	1.5	6.0	1.5	6.0	1.5	9.0	1.0	12.0	1.0	12.0
		3 Stage	2.5	6.0	2.5	6.0	2.5	9.0	1.5	12.0	1.5	12.0
3 Phase	208 Volt (3 Wire)	1 Stage	1.5	6.0	1.5	6.0	1.5	9.0	1.5	14.0	1.5	14.0
		2 Stage	1.5	6.0	1.5	6.0	1.5	9.0	1.5	14.0	1.5	14.0
		3 Stage	1.5	6.0	1.5	6.0	1.5	9.0	1.5	14.0	1.5	14.0
	480 Volt (4 Wire)	1 Stage	2.5	6.0	2.5	6.0	2.5	9.0	2.5	14.0	2.5	17.5
		2 Stage	2.5	6.0	2.5	6.0	2.5	9.0	2.5	14.0	2.5	17.5
		3 Stage	2.5	6.0	2.5	6.0	2.5	9.0	2.5	14.0	2.5	17.5

NOTES: Minimum and maximum values apply to staged heaters only. Contact your local Krueger representative for LineaHeat limits.

KLPS PSC Fan Curves

KLPS, PSC FAN CURVE, UNIT SIZE 3

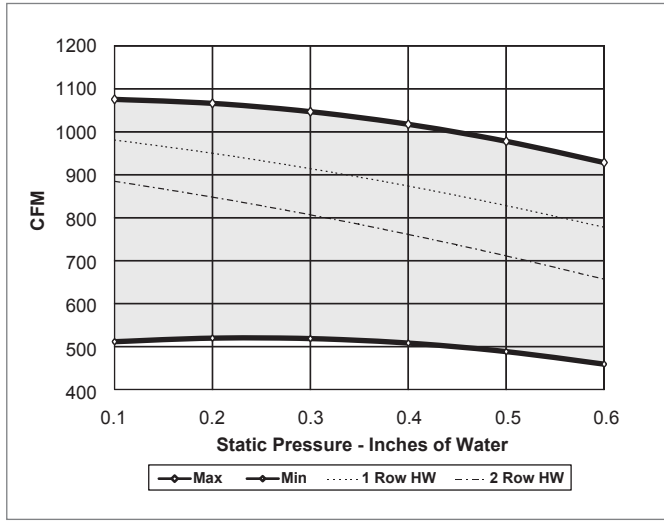

KLPS, PSC FAN CURVE, UNIT SIZE 4

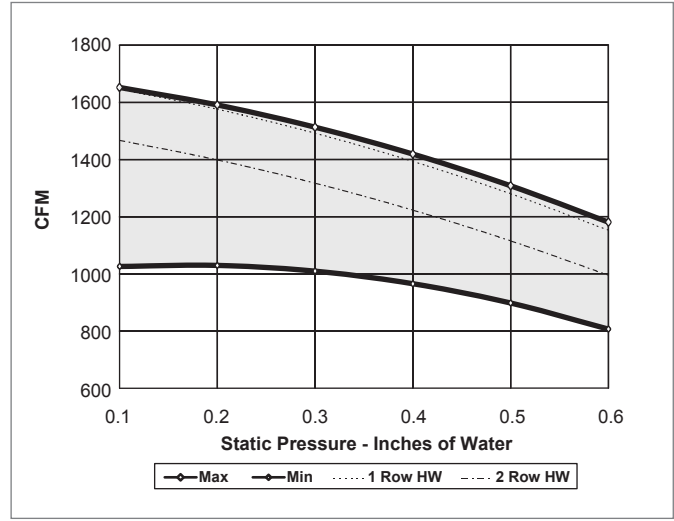

KLPS, PSC FAN CURVE, UNIT SIZE 5

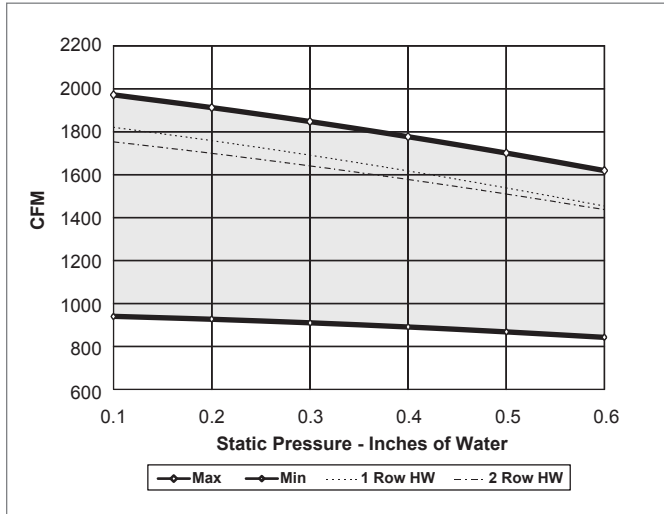

NOTES: Fan speed controller (SCR) is standard with each unit. Fan curves indicate maximum and minimum achievable flow reductions using SCR speed control. Units must be selected to operate within the flow and external static pressure ranges as shown. Fan discharge air volume will be reduced approximately 5% when unit is equipped with optional factory supplied electric heat coils.

FAN POWERED TERMINAL UNITS

KLPS

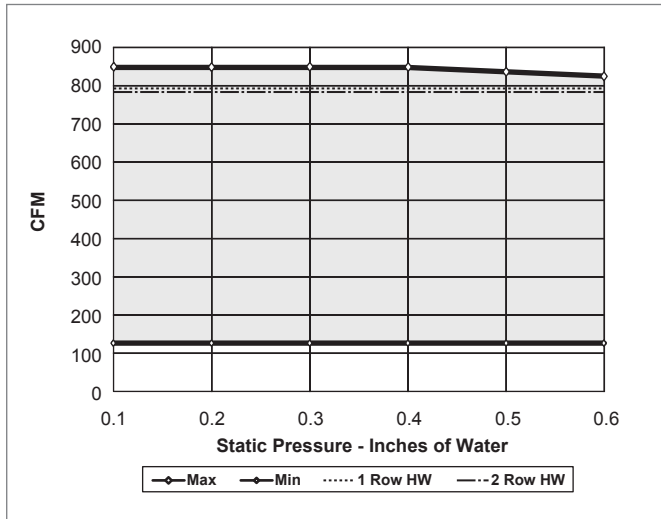
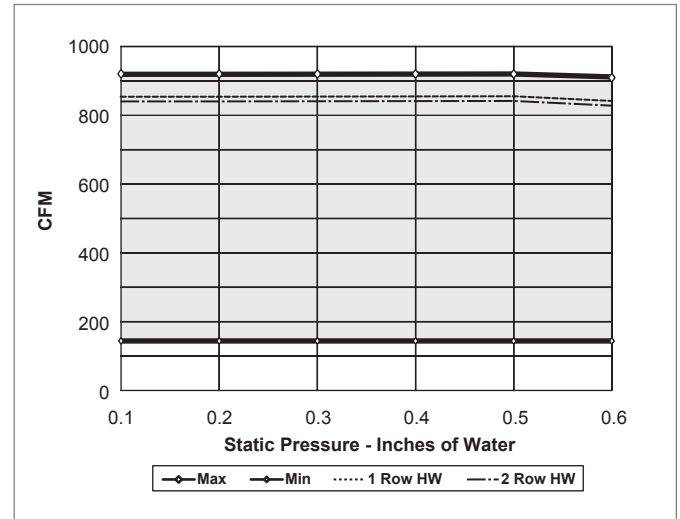
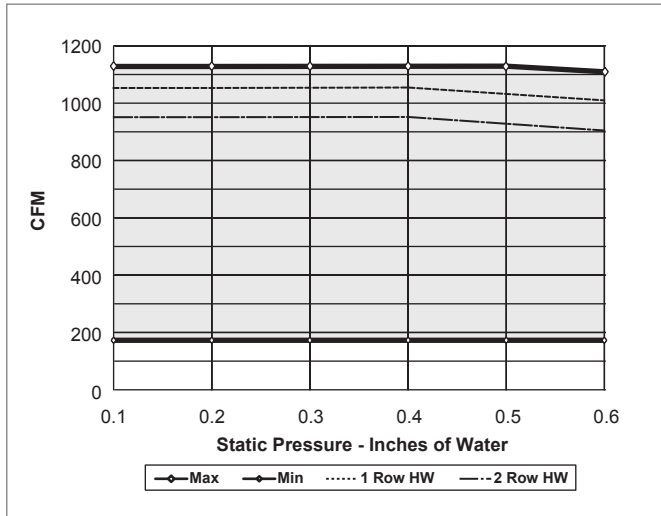
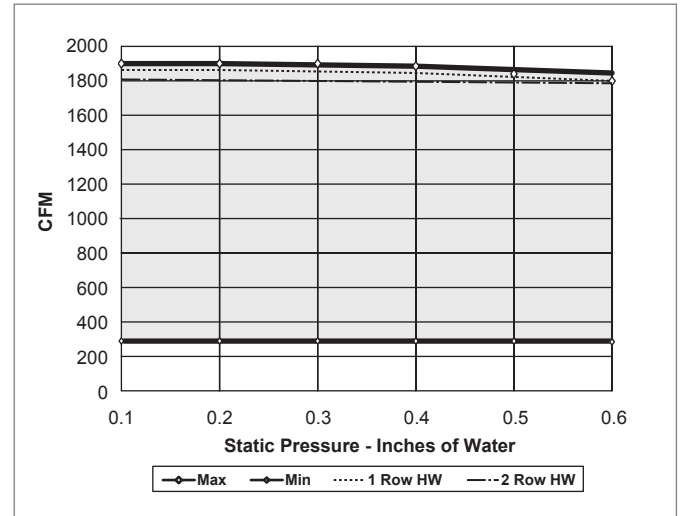
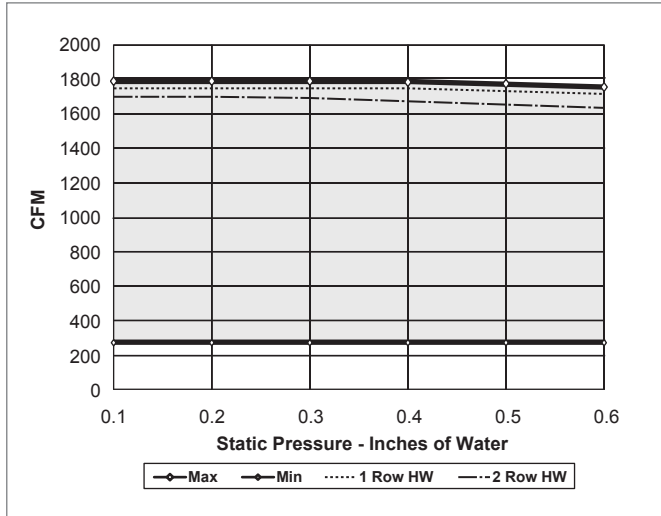
KLPS ECM Fan Curves
KLPS, ECM FAN CURVE, UNIT SIZE 1

KLPS, ECM FAN CURVE, UNIT SIZE 2

KLPS, ECM FAN CURVE, UNIT SIZE 3

KLPS, ECM FAN CURVE, UNIT SIZE 4

KLPS, ECM FAN CURVE, UNIT SIZE 5

NOTES: Manual or remote adjustable speed controller is standard with each unit. Fan curves indicate the maximum and minimum achievable airflows. See Product Description section, page B2-88 for definitions of manual and remote adjustable speed controllers. Units must be selected to operate within the airflow and external static pressure ranges shown.

AHRI Certified Performance Data for Series Fan Powered Terminal Units

KQFS, ULTRA QUIET SERIES FAN POWERED TERMINAL UNIT

Unit Size	Inlet Size	Primary CFM	Min. Ps	Fan		Discharge Data							Radiated Data											
						Fan Only Sound Power, Lw							Fan Only Sound Power, Lw							Fan + Primary @ 1.5" Inlet Ps				
				CFM	Watts	2	3	4	5	6	7	2	3	4	5	6	7	2	3	4	5	6	7	
2	6	400	0.100	450	190	73	63	56	49	43	45	67	55	52	48	43	35	68	57	55	51	47	44	
3	8	700	0.100	900	430	73	69	68	63	63	63	65	58	58	55	48	44	67	62	61	57	50	47	
4	10	1100	0.100	1200	480	73	71	70	66	63	64	62	57	59	50	44	41	69	63	63	55	51	49	
5	12	1600	0.100	1750	780	75	72	69	70	67	68	71	63	63	60	52	48	71	66	65	60	54	52	
6	14	2100	0.100	2400	1100	78	77	72	76	73	73	72	64	65	63	55	51	72	67	65	63	57	55	
7	16	2800	0.100	2800	1470	86	81	75	77	75	76	75	69	67	65	59	55	78	71	70	67	61	59	

QFC, SERIES FAN POWERED TERMINAL UNIT

Unit Size	Inlet Size	Primary CFM	Min. Ps	Fan		Discharge Data							Radiated Data											
						Fan Only Sound Power, Lw							Fan Only Sound Power, Lw							Fan + Primary @ 1.5" Inlet Ps				
				CFM	Watts	2	3	4	5	6	7	2	3	4	5	6	7	2	3	4	5	6	7	
2	6	400	0.100	450	200	65	65	66	62	58	57	65	64	57	54	46	42	70	71	65	57	52	49	
3	8	700	0.100	850	380	67	68	68	67	65	66	69	67	61	57	50	48	74	75	67	61	55	52	
4	10	1100	0.100	1350	555	67	67	70	68	65	61	69	67	61	57	53	49	75	73	67	61	56	53	
5	12	1600	0.100	2050	950	74	74	73	75	73	73	75	70	66	62	57	57	79	76	69	64	60	57	
6	14	2100	0.100	2400	1150	76	74	76	76	74	73	72	69	66	65	63	61	78	77	70	67	65	61	
7	16	2800	0.100	3600	2750	79	78	76	76	72	72	78	75	70	67	63	62	83	79	74	70	66	64	

KLPS, LOW PROFILE SERIES FAN POWERED TERMINAL UNIT

Unit Size	Inlet Size	Primary CFM	Min. Ps	Fan		Discharge Data							Radiated Data											
						Fan Only Sound Power, Lw							Fan Only Sound Power, Lw							Fan + Primary @ 1.5" Inlet Ps				
				CFM	Watts	2	3	4	5	6	7	2	3	4	5	6	7	2	3	4	5	6	7	
1	6	400	0.100	400	70	71	67	67	64	61	58	62	56	53	49	43	39	66	63	62	56	51	47	
2	8	700	0.100	700	150	79	76	76	75	74	73	70	64	60	57	51	48	75	73	70	64	59	55	
3	8	700	0.100	1000	460	78	69	67	67	65	63	69	60	58	56	51	44	69	62	60	56	51	46	
4	8x14	1400	0.100	1500	665	81	64	63	61	62	60	73	65	62	60	53	44	77	74	69	66	58	52	
5	12	1600	0.100	1700	680	78	73	72	73	70	69	68	60	57	53	48	42	68	65	61	56	55	58	

NOTES: All sound data is based on tests conducted in accordance with AHRI 880-11. ΔPs is the difference in static pressure from inlet to discharge. Sound power levels are in dB, re 10⁻¹² Watts. Discharge sound power is the sound emitted from the unit discharge. Discharge sound power has been corrected for end reflection. Radiated sound power is the sound transmitted through the casing walls. NC application data is from AHRI Standard 885-08 Appendix E. See Krueger's selection program for specific sound data for optional liners; 1/2", dual density liner shown. Dash indicates a NC is less than 20. See Krueger's Terminal Unit Engineering section for reductions and definitions. AHRI certification points are shown in bold white text in the sound performance data section for each of the corresponding models.



FAN POWERED TERMINAL UNITS

CERTIFIED - DATA

KLPS Discharge Sound Performance Data

KLPS, DISCHARGE SOUND DATA

FAN POWERED TERMINAL UNITS

Unit Size	Inlet Size	Primary Flow Rate		Fan Flow Rate		Min. Δ Ps		Fan Only							Fan + Primary @ 0.75" Δ Ps							Fan + Primary @ 1.5" Δ Ps									
								Octave Band Sound Power, Lw							Lp	Octave Band Sound Power, Lw							Lp	Octave Band Sound Power, Lw							Lp
								CFM	(L/s)	CFM	(L/s)	"WG	(Pa)	2	3	4	5	6	7	NC	2	3	4	5	6	7	NC	2	3	4	5
1	6	150	(71)	150	(71)	0.013	(3.25)	57	50	52	45	39	32	-	61	55	57	50	44	37	-	62	56	58	52	46	38	-			
		200	(95)	200	(95)	0.023	(5.75)	61	55	56	51	46	39	-	65	60	61	56	51	44	-	66	61	63	57	52	46	22			
		300	(142)	300	(142)	0.042	(10.50)	67	62	63	59	55	50	-	71	67	68	64	60	55	25	72	68	69	65	61	57	26			
		400	(189)	400	(189)	0.100	(25.00)	71	67	67	64	61	58	25	75	71	72	69	66	63	31	76	73	74	71	68	64	32			
		500	(237)	500	(237)	0.112	(24.85)	74	71	71	69	66	64	30	78	75	76	74	71	69	35	79	76	77	75	73	70	37			
2	8	200	(95)	200	(95)	0.003	(0.74)	61	55	56	51	46	39	-	65	60	61	56	51	44	-	66	61	63	57	52	46	22			
		325	(154)	325	(154)	0.015	(3.74)	68	63	64	60	57	52	-	72	68	69	65	62	57	27	73	69	70	67	63	59	28			
		450	(213)	450	(213)	0.036	(8.94)	72	69	69	67	64	61	28	77	73	74	72	69	66	33	78	75	76	73	71	68	35			
		575	(272)	575	(272)	0.065	(16.37)	76	73	73	72	70	68	33	80	78	78	76	75	73	38	81	79	80	78	76	74	40			
3	8	400	(189)	550	(260)	0.033	(8.11)	73	59	60	59	54	49	27	73	59	60	59	54	49	27	73	61	60	59	54	49	27			
		450	(212)	650	(307)	0.041	(10.27)	74	62	62	61	57	53	29	74	62	62	61	57	53	29	74	62	62	61	57	53	29			
		525	(248)	750	(354)	0.056	(13.98)	76	64	64	63	60	56	28	76	64	64	63	60	56	28	76	64	64	63	60	56	28			
		600	(283)	850	(401)	0.073	(18.25)	77	66	65	65	62	59	30	77	66	65	65	62	59	30	77	68	65	65	62	59	30			
		700	(330)	1000	(472)	0.100	(24.85)	78	69	67	67	65	63	32	78	69	67	67	65	63	32	80	69	69	67	65	63	34			
4	8x14	925	(437)	1025	(484)	0.044	(10.86)	79	59	59	56	56	51	32	79	62	59	56	56	51	32	79	65	61	58	58	51	32			
		1050	(496)	1150	(543)	0.056	(14.00)	79	61	60	58	57	54	33	79	63	60	58	57	54	33	79	66	63	60	59	54	33			
		1150	(543)	1250	(590)	0.067	(16.79)	80	62	61	59	59	56	34	80	64	61	59	59	56	34	82	67	64	61	61	56	36			
		1250	(590)	1350	(637)	0.080	(19.84)	80	63	62	60	60	57	34	80	65	62	60	60	57	34	82	68	64	62	62	57	37			
		1400	(661)	1500	(708)	0.100	(24.88)	81	64	63	61	62	60	35	81	66	63	61	62	60	35	83	69	66	63	63	60	38			
5	12	800	(378)	900	(425)	0.025	(6.21)	70	65	62	63	58	54	22	70	65	62	63	58	54	22	70	65	62	63	58	54	22			
		1000	(472)	1100	(519)	0.039	(9.71)	73	67	65	66	62	58	25	73	67	65	66	62	58	25	73	67	65	66	62	58	25			
		1200	(566)	1300	(614)	0.056	(13.98)	75	70	68	69	65	62	27	75	70	68	69	65	62	27	75	70	68	69	65	62	27			
		1400	(661)	1500	(708)	0.076	(19.02)	77	72	70	71	68	66	30	77	72	70	71	68	66	30	77	72	70	71	68	66	30			
		1600	(755)	1700	(802)	0.100	(24.85)	78	73	72	73	70	69	33	78	73	72	73	70	69	33	78	73	72	73	70	69	33			

NOTES: Discharge sound power is the sound emitted from the unit discharge. All sound data is based on tests conducted in accordance with AHRI 880-11 and corrected for end reflection. Sound power levels are in dB, re 10⁻¹² Watts. ΔPs is the difference in static pressure from inlet to discharge. NC application data is from AHRI Standard 885-08 Appendix E, as a function of flow rate shown. AHRI certification points are shown in bold, white font. For a complete list of AHRI certified data, see pages B2-4 and B2-5. All other data points listed are application ratings outside the scope of the Certification Program. See Krueger's selection program for specific sound data for optional liners; 1/2", dual density liner shown. Dash indicates a NC is less than 20. See Krueger's Terminal Unit Engineering section for reductions and definitions.

KLPS

KLPS Radiated Sound Performance Data
KLPS, RADIATED SOUND DATA

Unit Size	Inlet Size	Primary Flow Rate		Fan Flow Rate		Min. Δ Ps		Fan Only							Fan + Primary @ 0.75" Δ Ps							Fan + Primary @ 1.5" Δ Ps						
								Octave Band Sound Power, Lw							Lp	Octave Band Sound Power, Lw							Lp	Octave Band Sound Power, Lw				
		CFM	(L/s)	CFM	(L/s)	"WG	(Pa)	2	3	4	5	6	7	NC	2	3	4	5	6	7	NC	2	3	4	5	6	7	NC
1	6	150	(71)	150	(71)	0.013	(3.25)	48	44	42	36	29	22	13	48	44	44	38	31	27	15	48	44	46	39	33	31	17
		200	(95)	200	(95)	0.023	(5.75)	52	48	45	40	33	27	17	54	50	48	42	36	32	20	54	50	50	44	38	36	22
		300	(142)	300	(142)	0.042	(10.50)	58	53	50	46	39	34	22	61	56	54	49	43	39	26	61	57	57	51	45	43	29
		400	(189)	400	(189)	0.100	(25.00)	62	56	53	49	43	39	25	66	62	59	54	48	43	31	66	63	62	56	51	47	35
		500	(237)	500	(237)	0.112	(24.85)	65	59	56	53	46	42	28	70	66	63	58	52	47	37	70	68	66	60	55	51	39
2	8	200	(95)	200	(95)	0.003	(0.74)	52	48	45	40	33	27	17	52	48	47	40	35	31	19	52	48	49	43	37	34	21
		325	(154)	325	(154)	0.015	(3.74)	59	54	51	47	40	35	23	61	57	54	49	43	39	27	61	58	57	51	45	42	29
		450	(213)	450	(213)	0.036	(8.94)	63	58	55	51	45	40	27	67	63	59	55	49	44	32	67	64	62	56	51	48	35
		575	(272)	575	(272)	0.065	(16.37)	67	61	57	54	48	45	30	71	68	63	59	53	48	38	71	69	66	61	55	52	40
3	8	400	(189)	550	(260)	0.033	(8.11)	64	52	54	51	41	29	29	64	52	54	51	41	33	29	64	54	54	51	43	38	29
		450	(212)	650	(307)	0.041	(10.27)	65	54	55	52	44	34	30	65	54	55	52	44	36	30	65	54	55	52	44	39	30
		525	(248)	750	(354)	0.056	(13.98)	67	56	56	54	46	37	31	67	56	56	54	46	37	31	67	58	58	54	46	41	33
		600	(283)	850	(401)	0.073	(18.25)	68	58	57	55	48	40	32	68	58	57	55	48	40	32	68	60	59	55	48	43	34
		700	(330)	1000	(472)	0.100	(24.85)	69	60	58	56	51	44	34	69	60	58	56	51	44	34	69	62	60	56	51	46	35
4	8x14	925	(437)	1025	(484)	0.044	(10.86)	68	61	59	56	48	37	34	68	65	59	58	50	41	36	73	69	64	61	53	46	41
		1050	(496)	1150	(543)	0.056	(14.00)	69	62	60	57	49	39	35	69	67	60	60	52	43	37	74	71	65	62	54	48	42
		1150	(543)	1250	(590)	0.067	(16.79)	70	63	61	58	51	41	36	70	68	63	61	53	44	39	75	72	66	63	55	49	44
		1250	(590)	1350	(637)	0.080	(19.84)	71	64	61	59	52	42	37	71	69	64	62	54	45	40	76	73	68	64	56	50	45
		1400	(661)	1500	(708)	0.100	(24.88)	73	65	62	60	53	44	38	73	70	65	63	55	47	41	77	74	69	66	58	52	46
5	12	800	(378)	900	(425)	0.025	(6.21)	62	55	50	45	38	30	24	62	57	52	45	47	46	26	62	61	56	51	52	54	31
		1000	(472)	1100	(519)	0.039	(9.71)	63	56	52	48	41	33	27	63	58	52	48	48	47	28	63	62	58	53	53	55	33
		1200	(566)	1300	(614)	0.056	(13.98)	65	58	54	50	43	37	29	65	60	54	50	49	48	29	65	63	59	54	54	56	34
		1400	(661)	1500	(708)	0.076	(19.02)	66	59	56	51	46	39	31	66	61	56	51	50	49	31	66	64	60	55	54	57	35
		1600	(755)	1700	(802)	0.100	(24.85)	68	60	57	53	48	42	32	68	62	57	53	51	50	32	68	65	61	56	55	58	36

FAN POWERED TERMINAL UNITS

NOTES: Radiated sound power is the sound transmitted through the casing walls. All sound data is based on tests conducted in accordance with AHRI 880-11. Sound power levels are in dB, re 10⁻¹² Watts. ΔPs is the difference in static pressure from inlet to discharge. NC application data is from AHRI Standard 885-08 Appendix E. AHRI certification points are shown in bold, white font. For a complete list of AHRI certified data, see pages B2-4 and B2-5. All other data points listed are application ratings outside the scope of the Certification Program. See Krueger's selection program for specific sound data for optional liners; 1/2", dual density liner shown. Dash indicates a NC is less than 20. See Krueger's Terminal Unit Engineering section for reductions and definitions.

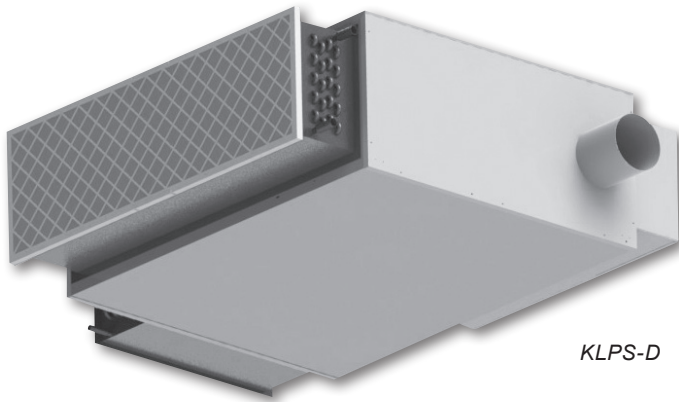

KLPS-D

Introduction: KLPS-D

The KLPS-D is a chilled series fan terminal unit designed to work with a dedicated outdoor air system (DOAS). The KLPS-D offers a sensible only cooling coil installed on the induced air inlet. It comes in four sizes to accommodate any zone requirement or ceiling height restriction. The size 1 unit is only 8 5/8" and size 2 is only 9 1/2" tall, both of which are designed to handle a small zone. The size 3 unit is 11" tall and will accommodate small to medium zones and the size 5 unit is 17" tall and will handle larger zones. The primary air inlet is sized to handle the fresh air zone ventilation requirements supplied from a DOAS air handler. The return air from the ceiling plenum passes through the sensible cooling coil and mixes with a fresh air provided by the primary inlet and supplies the required amount of conditioned air into the zone. The standard hot water and electric heat options are also available making the KLPS-D the ultimate single design solution for a buildings heating and cooling needs.

MODEL

KLPS-D - DOAS Construction, Chilled Series Fan Powered Terminal Unit

FEATURES

- Unit size 1: Ultra low profile at only 8 5/8" tall.
- Unit size 2: Ultra low profile at only 9 1/2" tall.
- Unit size 3: Only 11" high to accommodate installation in low height ceiling plenum spaces.
- Unit size 5: Only 17" high for extra capacity applications.
- Airflow capacities: Range up to 1550 CFM to allow airflow control for commercial applications.
- Cooling coil on the induced air inlet provides conditioned air into the space to handle the sensible cooling load.
- Heavy gage galvanized steel casing for unit strength and product durability.
- Several casing liner options provide quiet and clean operation.
- Fully removable, bottom access panel included with each unit for easy access to all internal components.
- Control enclosure located on left-hand or right-hand side for easier installation.
- Single point electrical connection minimizes number of ceiling plenum electrical connections.
- Energy efficient ECM (electronically commutated motor) fan motor.
- Manual adjustable speed controller or Building Management System compatible remote adjustable speed controller.
- Isolated motor/blower assembly limits casing acoustical transmission.
- ETL listings are under UL 1995 electrical safety.
- External filter option allows quick and easy access for routine replacement. MERV 8 filter available.
- Factory mounted digital controls may be customized for many building systems.
- Auxiliary heat offers a wide range of options, including electric and hot water heat.
- LineaHeat solid state electronic proportional control of electric heat is available with or without leaving air temperature control.
- AC solid state relays offer silent operation for staged electric heat.
- Revit models are available at www.krueger-hvac.com/revit.

KLPS-D Unit Capacities
KLPS-D UNIT CAPACITIES WITH ECM MOTOR

Unit Size	Inlet Size	KLPS-D with ECM Motor							
		Primary Airflow		Fan Airflow		Motor HP	Motor Amps		
		Max.	Min.	Max.	Min.		120V	208/240V	277V
1	4	230	40	775	105	1/3	5.0	3.3	2.6
	5	320	60						
	6	515	90						
	7	700	120						
2	4	230	40	875	135	1/3	5.0	3.3	2.6
	5	320	60						
	6	515	90						
	7	700	120						
3	4	230	40	1000	150	1/3	5.0	3.3	2.6
	5	320	60						
	6	515	90						
	7	700	120						
	8	920	160						
5	6	515	90	1625	250	1/2	7.7	5.0	4.1
	7	700	120						
	8	920	160						
	10	1430	250						

NOTES: KLPS-D maximum primary airflow (CFM) is based on 1.00" WG differential pressure signal from inlet airflow sensor until the value reaches maximum fan CFM for that unit size. A properly balanced unit will be set so the maximum primary CFM is never greater than the fan CFM. Minimum recommended airflow (CFM) is based on 0.03" WG differential pressure of the inlet airflow sensor, or 0 CFM. 0.03" WG is equal to 15%–20% of the nominal flow rating of the terminal. Less than 15%-20% may result in greater than +/-5% control of box flow. Maximum/minimum fan airflow (CFM) is based on 0.10"/0.60" WG external downstream static pressure. See page B2-109 for complete fan curves.

KLPS-D Damper Leakage
KLPS-D, DAMPER LEAKAGE DETAIL

Inlet Size	Damper Leakage		
	1.5" WG CFM	3.0" WG CFM	6.0" WG CFM
4	4	5	7
5	4	5	7
6	4	5	7
7	4	5	7
8	4	5	7
10	4	5	7

NOTES: Damper leakage is measured with the damper fully closed using an actuator. A precision low flow orifice is used upstream of the unit to measure the leakage rate as a function of the measured upstream static pressure. Leakage testing conducted in accordance with ASHRAE 130-2008.

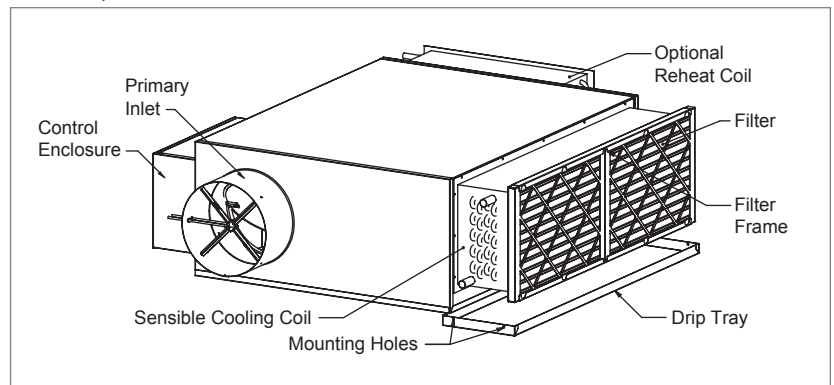
KLPS-D Unit Attributes
KLPS-D, ANGLED VIEW

FAN POWERED TERMINAL UNITS

KLPS

KLPS-D Base Unit Dimensional Information

KLPS-D BASE UNIT, INLET, PLAN, AND DISCHARGE VIEWS

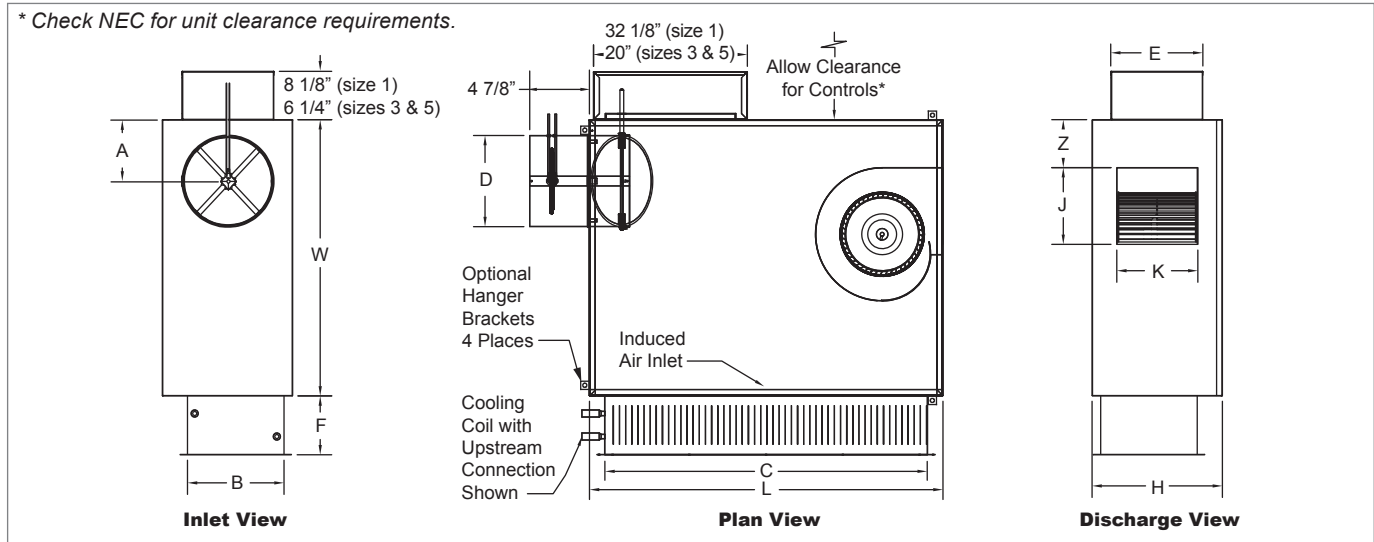

KLPS-D BASE UNIT, DIMENSIONAL DETAILS

Unit Size	ECM HP	L	W	H	Cooling Coil		E	Discharge		Z	F		
					B	C		J	K		2 Row	4 Row	6 Row
1	1/3	48"	32"	8 5/8"	7 1/2"	36"	8 1/8"	10"	5 7/8"	2"	7 7/8"	7 7/8"	10"
2	1/3	48"	32"	9 1/2"	7 1/2"	36"	8 1/8"	10"	5 7/8"	2"	7 7/8"	7 7/8"	10"
3	1/3	40"	26"	11"	8 3/4"	36"	9 5/8"	9"	6 7/8"	2 1/4"	7 7/8"	7 7/8"	10"
5	1/2	46"	36"	17"	12 1/2"	42"	12"	10"	10 5/8"	6 1/4"	7 7/8"	7 7/8"	10"

Unit Size	1				2				3				5				
Inlet Size	04	05	06	07	04	05	06	07	04	05	06	07	08	06	07	08	10
A	5"	5"	5"	5"	5"	5"	5"	5"	5"	6"	5"	6"	5"	5"	6"	6"	7"
D	3 7/8"	4 7/8"	5 7/8"	6 7/8"	3 7/8"	4 7/8"	5 7/8"	6 7/8"	3 7/8"	4 7/8"	5 7/8"	6 7/8"	7 7/8"	5 7/8"	6 7/8"	7 7/8"	9 7/8"

NOTE: Left-hand base unit with electronic control enclosure shown; right-hand is available.

KLPS-D Base Unit Features & Options

STANDARD FEATURES

- 20 gage galvanized steel casing construction.
- Available in unit sizes 1, 2, 3, and 5.
- Control enclosure for electronic components.
- 1/2" thick, dual density fiberglass insulation that meets NFPA 90A and UL 181 safety requirements.
- [120, 208/240, or 277 volt, single-voltage] ECM motor.
- Manual or remote adjustable speed controller.
- Removable bottom panel allows easy access to all internal components for maintenance.
- Four quadrant, center averaging airflow sensor.
- Includes 24 volt control transformer.
- Sensible Cooling Coil factory installed on induced air inlet with drip tray.
- Construction type air filter, two per unit, unit size 1 (18 7/8"x7 1/2"x1"), unit size 2 (18 7/8"x8 3/8"x1"), unit size 3 (18 1/2"x10"x1"), unit size 5 (22"x14 1/2"x1").
- ETL listed; adherence to UL 1995 and CSA C22.2 No. 236.95

OPTIONAL FEATURES

- Liners: 1/2" or 1" Cellular insulation, 1/2" or 1" Foil encapsulated fiberglass insulation, Sterilwall, Perforated doublewall, 1" Dual density fiberglass. *NOTE: 1" thick liner options are available on unit size 5 only.*
- Linear averaging airflow sensor.
- Left-hand or right-hand control enclosure.
- Upstream or downstream cooling coil connection.
- Motor toggle disconnect switch.
- Motor fusing.
- MERV 8 air filter, two per unit, unit size 1 (18 7/8"x 7 1/2" x1"), unit size 2 (18 7/8"x8 3/8"x1"), unit size 3 (18 1/2"x10"x1"), and unit size 5 (22"x14 1/2"x1").
- Dust tight control enclosure.
- Hanger brackets.
- Dual access panels with optional Cam locks.

FAN POWERED TERMINAL UNITS

KLPS-D

© KRUEGER 2012

KLPS-D Unit with Hot Water Heat Dimensional Information

KLPS-D UNIT WITH HOT WATER HEAT, INLET, PLAN, AND DISCHARGE VIEWS

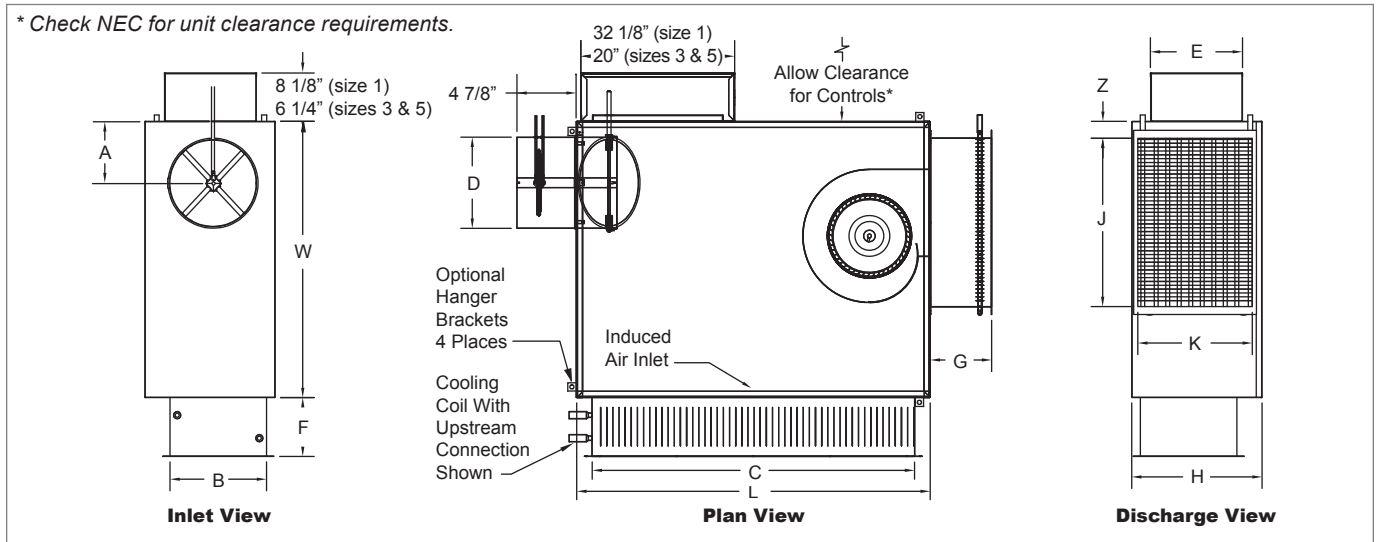

KLPS-D UNIT WITH HOT WATER HEAT, DIMENSIONAL DETAILS

Unit Size	ECM HP	L	W	H	Cooling Coil			Discharge			F			G	
					B	C	E	J	K	Z	2 Row	4 Row	6 Row	1 Row	2 Row
1	1/3	48"	32"	8 5/8"	7 1/2"	36"	8 1/8"	20 1/2"	7 5/8"	1 1/2"	7 7/8"	7 7/8"	10"	9 1/2"	9 1/2"
2	1/3	48"	32"	9 1/2"	7 1/2"	36"	8 1/8"	20 1/2"	7 5/8"	1 1/2"	7 7/8"	7 7/8"	10"	9 1/2"	9 1/2"
3	1/3	40"	26"	11"	8 3/4"	36"	9 5/8"	21 1/8"	8 3/4"	1"	7 7/8"	7 7/8"	10"	9 1/2"	9 1/2"
5	1/2	46"	36"	17"	12 1/2"	42"	12"	22"	15"	2 1/4"	7 7/8"	7 7/8"	10"	8"	9 3/16"

Unit Size	1				2				3				5				
Inlet Size	04	05	06	07	04	05	06	07	04	05	06	07	08	06	07	08	10
A	5"	5"	5"	5"	5"	5"	5"	5"	5"	6"	5"	6"	5"	5"	6"	6"	7"
D	3 7/8"	4 7/8"	5 7/8"	6 7/8"	3 7/8"	4 7/8"	5 7/8"	6 7/8"	3 7/8"	4 7/8"	5 7/8"	6 7/8"	7 7/8"	5 7/8"	6 7/8"	7 7/8"	9 7/8"

NOTE: Left-hand base unit with electronic control enclosure shown; right-hand is available.

KLPS-D Unit with Hot Water Heat Features & Options

STANDARD FEATURES

- 20 gage galvanized steel casing construction.
- Available in unit sizes 1, 2, 3, and 5.
- Control enclosure for electronic components.
- 1/2" thick, dual density fiberglass insulation that meets NFPA 90A and UL 181 safety requirements.
- [120, 208/240, or 277 volt, single-voltage] ECM motor.
- Manual or remote adjustable speed controller.
- Removable bottom panel allows easy access to all internal components for maintenance.
- Four quadrant, center averaging airflow sensor.
- Flanged discharge connection on hot water coil.
- Includes 24 volt control transformer.
- Sensible Cooling Coil factory installed on induced air inlet with drip tray.
- Construction type air filter, two per unit, unit size 1 (18 7/8"x7 1/2"x1"), unit size 2 (18 7/8"x8 3/8"x1"), unit size 3 (18 1/2"x10"x1"), unit size 5 (22"x14 1/2"x1").
- ETL listed; adherence to UL 1995 and CSA C22.2 No. 236.95.

OPTIONAL FEATURES

- Liners: 1/2" or 1" Cellular insulation, 1/2" or 1" Foil encapsulated fiberglass insulation, Sterilwall, Perforated doublewall, 1" Dual density fiberglass. *NOTE: 1" thick liner options are available on unit size 5 only.*
- Linear averaging airflow sensor.
- Left-hand or right-hand control enclosure.
- Left-hand or right-hand hot water coil connection.
- Upstream or downstream cooling coil connection.
- Motor toggle disconnect switch.
- Motor fusing.
- MERV 8 air filter, two per unit, unit size 1 (18 7/8"x7 1/2"x1"), unit size 2 (18 7/8"x8 3/8"x1"), unit size 3 (18 1/2"x10"x1"), and unit size 5 (22"x14 1/2"x1").
- Dust tight control enclosure.
- Hanger brackets.
- Dual access panels with optional Cam locks.

KLPS-D Unit with Electric Heat Dimensional Information

KLPS-D UNIT WITH ELECTRIC HEAT, INLET, PLAN, AND DISCHARGE VIEWS

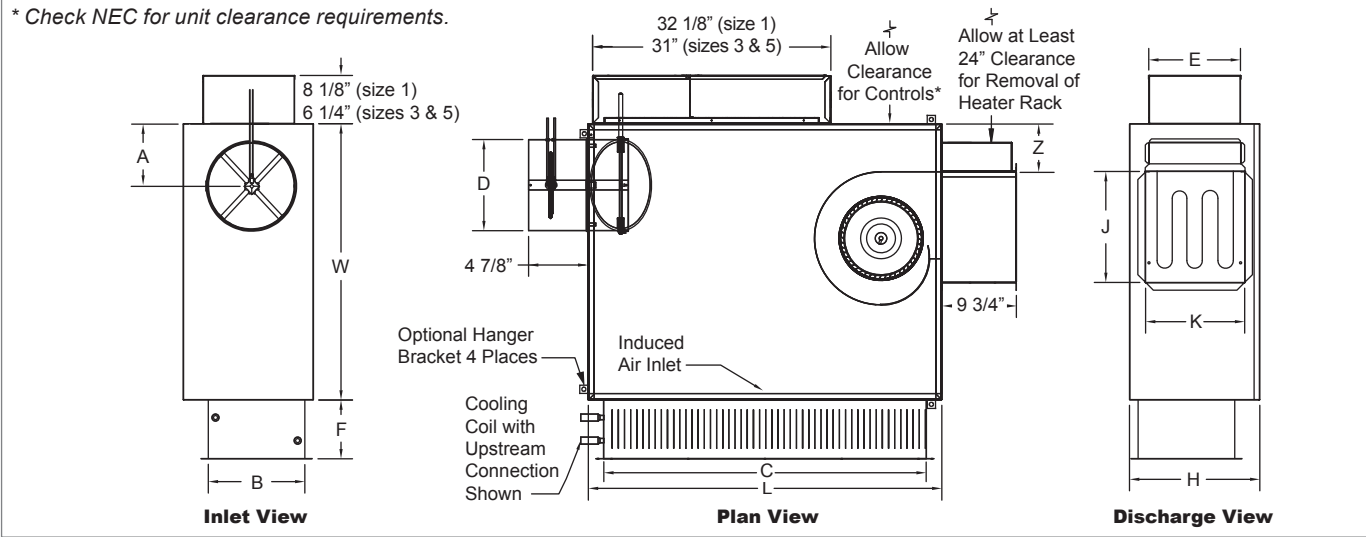

KLPS-D UNIT WITH ELECTRIC HEAT, DIMENSIONAL DETAILS

Unit Size	ECM HP	L	W	H	Cooling Coil		E	Discharge		Z	F		
					B	C		J	K		2 Row	4 Row	6 Row
1	1/3	48"	32"	8 5/8"	7 1/2"	36"	8 1/8"	10 1/2"	7 3/4"	1 1/8"	7 7/8"	7 7/8"	10"
2	1/3	48"	32"	9 1/2"	7 1/2"	36"	8 1/8"	10 1/2"	7 3/4"	1 1/8"	7 7/8"	7 7/8"	10"
3	1/3	40"	26"	11"	8 3/4"	36"	9 5/8"	10 1/2"	8 3/8"	1 1/8"	7 7/8"	7 7/8"	10"
5	1/2	46"	36"	17"	12 1/2"	42"	12"	14 1/2"	12 7/8"	6 1/4"	7 7/8"	7 7/8"	10"

Unit Size	1				2				3				5				
Inlet Size	04	05	06	07	04	05	06	07	04	05	06	07	08	06	07	08	10
A	5"	5"	5"	5"	5"	5"	5"	5"	5"	6"	5"	6"	5"	5"	6"	6"	7"
D	3 7/8"	4 7/8"	5 7/8"	6 7/8"	3 7/8"	4 7/8"	5 7/8"	6 7/8"	3 7/8"	4 7/8"	5 7/8"	6 7/8"	7 7/8"	5 7/8"	6 7/8"	7 7/8"	9 7/8"

NOTES: Left-hand base unit with electronic control enclosure shown; right-hand is available. See page B2-97 for electric heat standard features.

KLPS-D Unit with Electric Heat Features & Options

STANDARD FEATURES

- 20 gage galvanized steel casing construction.
- Available in unit sizes 1, 2, 3, and 5.
- Control enclosure for electronic components.
- 1/2" thick, dual density fiberglass insulation that meets NFPA 90A and UL 181 safety requirements.
- [120, 208/240, or 277 volt, single-voltage] ECM motor.
- Manual or remote adjustable speed controller.
- Removable bottom panel allows easy access to all internal components for maintenance.
- Four quadrant, center averaging airflow sensor.
- Flanged discharge connection on electric heat coil.
- Single point electrical connection.
- Includes 24 volt control transformer.
- Sensible Cooling Coil factory installed on induced air inlet with drip tray.
- Construction type air filter, two per unit, unit size 1 (18 7/8"x7 1/2"x1"), unit size 2 (18 7/8"x8 3/8"x1"), unit size 3 (18 1/2"x10"x1"), unit size 5 (22"x14 1/2"x1").
- ETL listed; adherence to UL 1995 and CSA C22.2 No. 236.95.

OPTIONAL FEATURES

- LineaHeat solid state electronic controlled heater with or without leaving air temperature control.
- Liners: 1/2" or 1" Cellular insulation, 1/2" or 1" Foil encapsulated fiberglass insulation, Sterilwall, Perforated doublewall, 1" Dual density fiberglass. *NOTE: 1" thick liner options are available on unit size 5 only.*
- Linear averaging airflow sensor.
- Left-hand or right-hand control enclosure.
- Upstream or downstream cooling coil connection
- **MERV 8 air filter, two per unit, unit size 1 (18 7/8"x7 1/2"x1"), unit size 2 (18 7/8"x8 3/8"x1"), unit size 3 (18 1/2"x10"x1"), and unit size 5 (22"x14 1/2"x1").**
- Fused or non-fused door interlocking disconnect.
- Dust tight control enclosure.
- Hanger brackets.
- Motor fusing.
- AC Solid State Relays.
- Manual reset cutout.
- Fuse-block.
- Dual access panels with optional Cam locks.

FAN POWERED TERMINAL UNITS

KLPS

© KRUEGER 2012

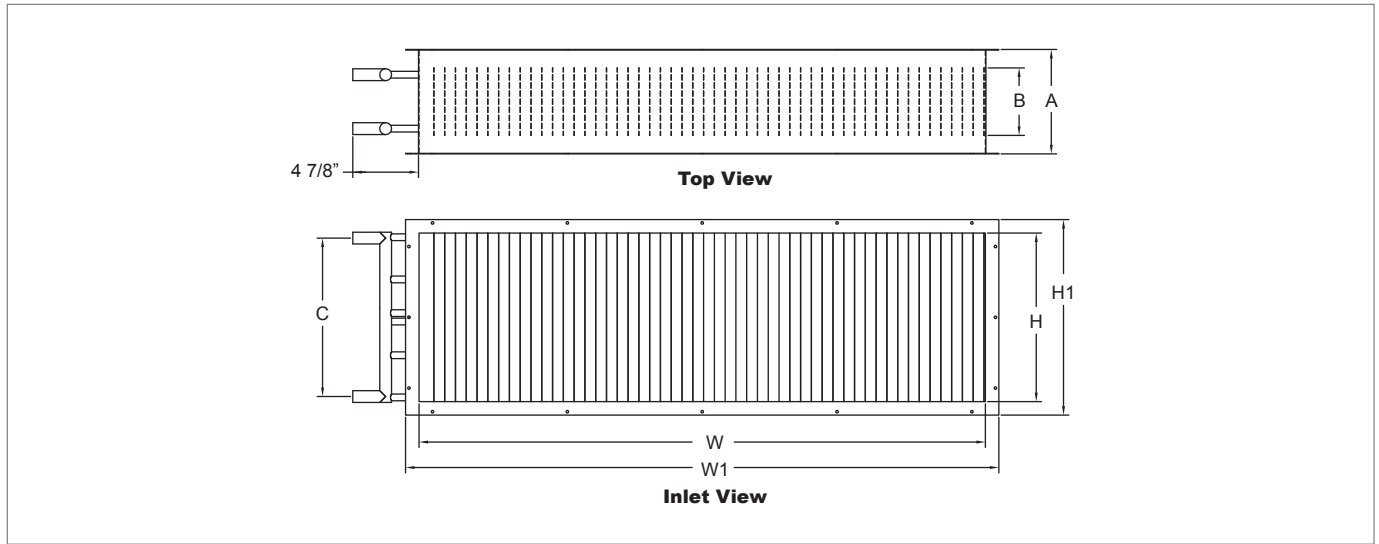
KLPS-D Cooling Water Coil Dimensional Information
KLPS-D COOLING WATER COIL, PLAN AND FRONT VIEWS

KLPS-D COOLING WATER COIL, DIMENSIONAL DETAILS

Unit Size	Number of Rows	W	H	W1	H1	A	B	C
1	2	36"	$7\frac{1}{2}$ "	38"	$7\frac{5}{8}$ "	$7\frac{7}{8}$ "	$2\frac{1}{8}$ "	$6\frac{3}{4}$ "
	4					$7\frac{7}{8}$ "	$4\frac{3}{8}$ "	
	6					10"	$6\frac{1}{2}$ "	
2	2	36"	$7\frac{1}{2}$ "	38"	$8\frac{1}{2}$ "	$7\frac{7}{8}$ "	$2\frac{1}{8}$ "	$6\frac{3}{4}$ "
	4					$7\frac{7}{8}$ "	$4\frac{3}{8}$ "	
	6					10"	$6\frac{1}{2}$ "	
3	2	36"	$8\frac{3}{4}$ "	38"	$10\frac{1}{4}$ "	$7\frac{7}{8}$ "	$2\frac{1}{8}$ "	8"
	4					$7\frac{7}{8}$ "	$4\frac{3}{8}$ "	
	6					10"	$6\frac{1}{2}$ "	
5	2	42"	$12\frac{1}{2}$ "	44"	$14\frac{1}{2}$ "	$7\frac{7}{8}$ "	$2\frac{1}{8}$ "	$11\frac{3}{4}$ "
	4					$7\frac{7}{8}$ "	$4\frac{3}{8}$ "	
	6					10"	$6\frac{1}{2}$ "	

KLPS-D Cooling Water Coil Features
STANDARD FEATURES

- Cooling coils are shipped from the factory attached to the induction inlet.
- Drip tray ships loose from the factory to be attached to the water coil in the field.
- Filter rack is shipped from the factory attached to the water coil.
- Connection Tubing: $\frac{7}{8}$ " O. D. male solder.
- Coil Casing: 18 gage galvanized steel.
- Coil Tubing: $\frac{1}{2}$ " O. D. x 0.016" thick copper.
- Coil Fins: 0.0045" thick aluminum, 10 per inch; mechanically bonded to tubing.

NOTES: Entering water temperature must be above dew point to prevent condensation on coil.
 Typical design entering water temperature for cooling coil ranges from 55°F to 60°F.

KLPS-D Cooling Water Coil Performance Data

KLPS-D COOLING WATER COIL PERFORMANCE DATA

FAN POWERED TERMINAL UNITS

Unit Size	Rows	GPM	Head Loss	Cooling Coil Airflow, CFM & Resulting Sensible MBH								
				150	225	300	375	450	525	600	675	750
1 & 2	2	1.0	0.15	-1.8	-2.3	-2.7	-3.0	-3.2	-3.4	-3.6	-3.7	-3.8
		2.0	0.50	-2.0	-2.7	-3.2	-3.6	-4.0	-4.3	-4.6	-4.8	-5.0
		4.0	1.02	-2.1	-2.8	-3.4	-3.9	-4.3	-4.7	-5.1	-5.4	-5.6
		6.0	1.69	-2.1	-2.9	-3.5	-4.1	-4.5	-5.0	-5.3	-5.7	-6.0
		Air Pressure Drop		0.01	0.01	0.02	0.04	0.05	0.06	0.08	0.10	0.12
	4	1.0	0.29	-2.5	-3.4	-4.0	-4.5	-4.9	-5.2	-5.4	-5.6	-5.8
		2.0	0.99	-2.6	-3.7	-4.6	-5.4	-6.0	-6.6	-7.1	-7.5	-7.9
		4.0	3.39	-2.7	-3.9	-4.9	-5.9	-6.7	-7.5	-8.2	-8.8	-9.4
		6.0	6.95	-2.7	-3.9	-5.0	-6.0	-7.0	-7.8	-8.6	-9.4	-10.0
		Air Pressure Drop		0.01	0.03	0.05	0.07	0.09	0.12	0.16	0.19	0.23
	6	1.0	0.44	-2.7	-3.8	-4.6	-5.2	-5.7	-6.1	-6.4	-6.6	-6.8
		2.0	1.49	-2.8	-4.0	-5.2	-6.1	-7.0	-7.7	-8.4	-8.9	-9.4
4.0		5.08	-2.8	-4.1	-5.4	-6.5	-7.6	-8.6	-9.5	-10.4	-11.2	
6.0		10.42	-2.8	-4.2	-5.4	-6.7	-7.8	-8.9	-9.9	-10.9	-11.8	
Air Pressure Drop		0.02	0.04	0.07	0.10	0.14	0.18	0.23	0.29	0.35		

Unit Size	Rows	GPM	Head Loss	Cooling Coil Airflow, CFM & Resulting Sensible MBH								
				300	375	450	525	600	675	750	825	900
3	2	1.0	0.18	-2.9	-3.2	-3.4	-3.6	-3.8	-4.0	-4.1	-4.2	-4.3
		2.0	0.60	-3.4	-3.8	-4.2	-4.6	-4.9	-5.2	-5.4	-5.6	-5.8
		4.0	1.23	-3.6	-4.1	-4.6	-5.0	-5.4	-5.7	-6.0	-6.3	-6.6
		6.0	2.05	-3.7	-4.3	-4.8	-5.3	-5.7	-6.1	-6.4	-6.7	-7.0
		Air Pressure Drop		0.02	0.03	0.04	0.05	0.06	0.08	0.09	0.11	0.13
	4	1.0	0.34	-4.1	-4.6	-5.0	-5.3	-5.6	-5.8	-6.0	-6.1	-6.3
		2.0	1.18	-4.7	-5.5	-6.2	-6.8	-7.3	-7.7	-8.1	-8.5	-8.8
		4.0	4.02	-5.0	-5.9	-6.8	-7.6	-8.4	-9.0	-9.7	-10.2	-10.8
		6.0	8.25	-5.0	-6.1	-7.0	-7.9	-8.8	-9.5	-10.3	-10.9	-11.6
		Air Pressure Drop		0.03	0.05	0.07	0.09	0.12	0.15	0.18	0.21	0.25
	6	1.0	0.51	-4.6	-5.3	-5.8	-6.2	-6.5	-6.7	-6.9	-7.0	-7.2
		2.0	1.76	-5.2	-6.2	-7.1	-7.8	-8.5	-9.1	-9.6	-10.1	-10.5
4.0		6.00	-5.3	-6.5	-7.6	-8.7	-9.6	-10.5	-11.3	-12.1	-12.8	
6.0		12.30	-5.4	-6.6	-7.8	-8.9	-10.0	-11.0	-11.9	-12.8	-13.6	
Air Pressure Drop		0.05	0.08	0.11	0.14	0.18	0.22	0.26	0.31	0.36		

Unit Size	Rows	GPM	Head Loss	Cooling Coil Airflow, CFM & Resulting Sensible MBH								
				450	550	650	750	850	950	1050	1150	1250
5	2	1.0	0.3	-4.3	-4.7	-5.0	-5.2	-5.4	-5.4	-5.6	-5.7	-5.8
		2.0	0.9	-5.3	-5.9	-6.4	-6.9	-7.3	-7.4	-7.7	-8.0	-8.2
		3.0	1.9	-5.6	-6.4	-7.1	-7.6	-8.2	-8.3	-8.8	-9.1	-9.5
		4.0	3.2	-5.8	-6.7	-7.4	-8.1	-8.7	-8.9	-9.4	-9.8	-10.2
		Air Pressure Drop		0.01	0.02	0.03	0.04	0.05	0.06	0.07	0.08	0.09
	4	1.0	0.5	-5.9	-6.4	-6.8	-7.1	-7.3	-7.5	-7.6	-7.7	-7.8
		2.0	1.8	-7.1	-8.1	-8.9	-9.6	-10.2	-10.8	-11.2	-11.6	-12.0
		3.0	3.6	-7.4	-8.6	-9.7	-10.6	-11.5	-12.3	-12.9	-13.5	-14.1
		4.0	6.0	-7.6	-8.9	-10.1	-11.2	-12.2	-13.1	-13.9	-14.7	-15.4
		Air Pressure Drop		0.03	0.04	0.06	0.07	0.09	0.11	0.13	0.15	0.18
	6	1.0	0.4	-6.3	-6.9	-7.3	-7.5	-7.7	-7.9	-8.0	-8.1	-8.2
		2.0	1.5	-7.7	-8.9	-9.9	-10.7	-11.4	-12.0	-12.5	-13.0	-13.3
4.0		5.1	-8.1	-9.7	-11.1	-12.5	-13.7	-14.8	-15.8	-16.7	-17.6	
6.0		10.5	-8.2	-9.9	-11.5	-13.0	-14.4	-15.7	-16.9	-18.1	-19.2	
Air Pressure Drop		0.04	0.06	0.08	0.11	0.13	0.16	0.19	0.23	0.26		

NOTES: All data is based on 75°F entering air, 57°F entering water, at an altitude of 0 ft. Program calculations assume 0% glycol. Water temperature of must be above dew point throughout the building to prevent condensation on coil. Typical entering water temperature for cooling coil ranges from 55°F to 62°F.

The MBH values listed above is the sensible MBH for the CFM that is induced through the cooling coil. The latent MBH is provided by the primary air and is added to the sensible MBH to create the Total Cooling MBH.

KLPS

© KRUEGER 2012

KLPS-D ECM Fan Curves

KLPS-D, ECM FAN CURVE, UNIT SIZE 1

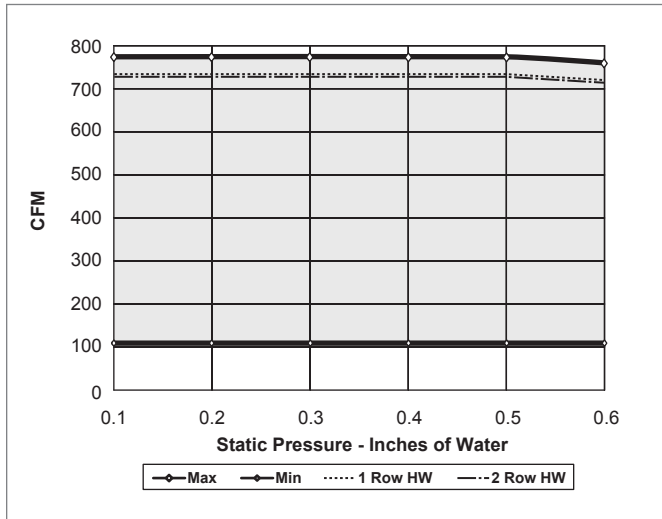

KLPS-D, ECM FAN CURVE, UNIT SIZE 2

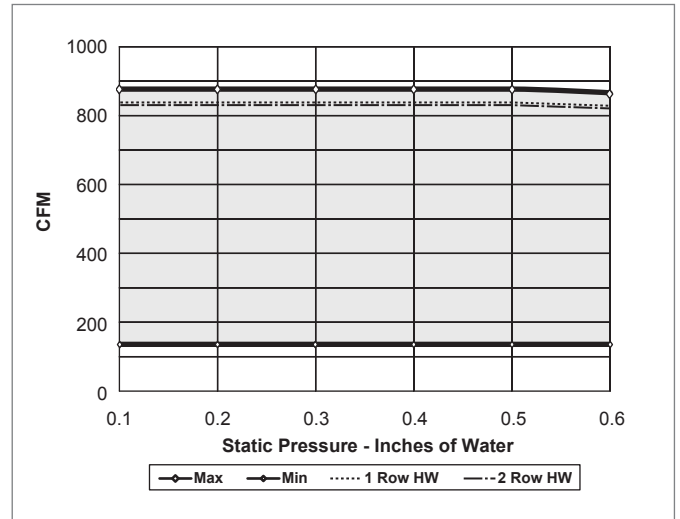

KLPS-D, ECM FAN CURVE, UNIT SIZE 3

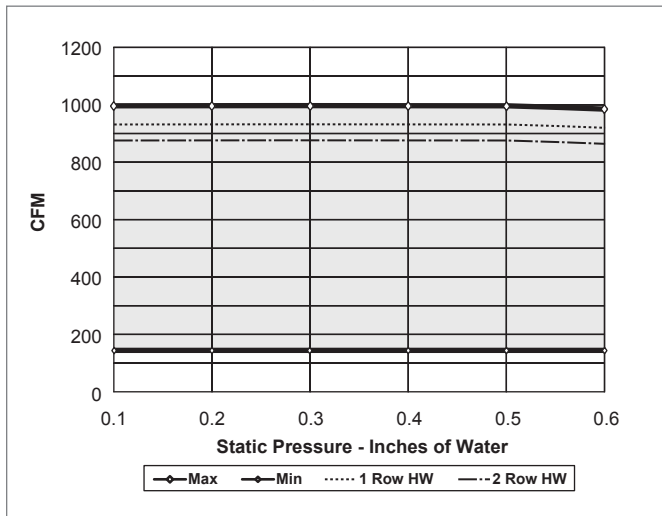

KLPS-D, ECM FAN CURVE, UNIT SIZE 5

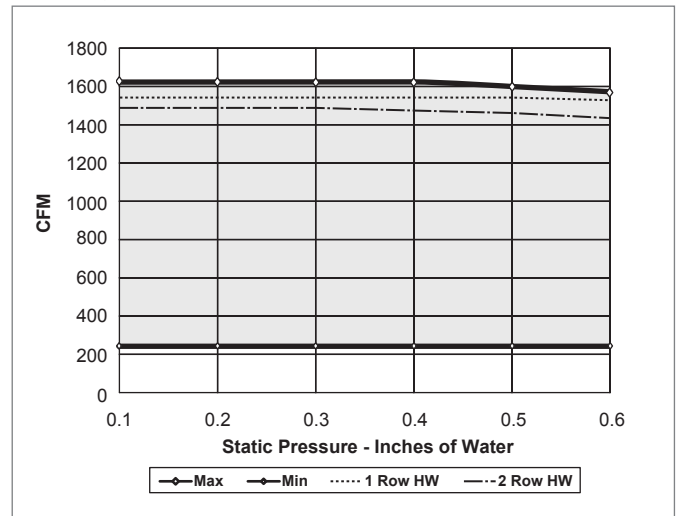

NOTES: Manual or remote adjustable speed controller is standard with each unit. Fan curves indicate the maximum and minimum achievable airflows. See Product Description section, page B2-88 for definitions of manual and remote adjustable speed controllers. Units must be selected to operate within the airflow and external static pressure ranges shown.

Fan curves are based on a 6 row cooling coil installed on the induced air inlet.

FAN POWERED TERMINAL UNITS

KLPS

KLPS-D Discharge Sound Performance Data

KLPS-D, DISCHARGE SOUND DATA

FAN POWERED TERMINAL UNITS

Unit Size	Inlet Size	Primary Flow Rate		Fan Flow Rate		Min. Δ Ps		Fan Only							Fan + Primary @ 0.75" Δ Ps							Fan + Primary @ 1.5" Δ Ps						
								Octave Band Sound Power, Lw							Lp	Octave Band Sound Power, Lw							Lp	Octave Band Sound Power, Lw				
		CFM	(L/s)	CFM	(L/s)	"WG	(Pa)	2	3	4	5	6	7	NC	2	3	4	5	6	7	NC	2	3	4	5	6	7	NC
1	4	40	(19)	200	(94)	0.003	(0.74)	58	52	52	47	42	35	-	58	52	52	47	42	35	-	58	52	52	47	42	35	-
		75	(35)	325	(153)	0.010	(2.60)	64	60	59	56	53	48	-	64	60	59	56	53	48	-	64	60	59	56	53	48	-
		125	(59)	450	(212)	0.029	(7.21)	69	66	65	63	60	57	24	69	66	65	63	60	57	26	69	66	65	63	60	57	26
		175	(83)	575	(271)	0.057	(14.14)	72	70	69	67	65	64	29	72	70	69	67	65	64	30	72	70	69	67	65	64	30
		232	(109)	675	(319)	0.100	(24.85)	75	73	71	70	69	68	33	75	73	71	70	69	68	33	75	73	71	70	69	68	33
1	5	63	(30)	200	(94)	0.003	(0.75)	58	52	52	47	42	35	-	58	52	52	47	42	35	-	58	52	52	47	42	35	-
		150	(71)	325	(153)	0.017	(4.24)	64	60	59	56	53	48	-	64	60	59	56	53	48	-	64	60	59	56	53	48	-
		225	(106)	450	(212)	0.038	(9.55)	69	66	65	63	60	57	24	69	66	65	63	60	57	26	69	66	65	63	60	57	26
		300	(142)	575	(271)	0.068	(16.97)	72	70	69	67	65	64	29	72	70	69	67	65	64	29	72	70	69	67	65	64	29
		363	(171)	675	(319)	0.100	(24.85)	75	73	71	70	69	68	33	75	73	71	70	69	68	33	75	73	71	70	69	68	33
1	6	150	(71)	200	(94)	0.011	(2.76)	58	52	52	47	42	35	-	60	54	54	49	42	35	-	60	55	55	49	44	37	-
		225	(106)	325	(153)	0.025	(6.21)	64	60	59	56	53	48	-	66	60	61	56	53	48	22	67	62	62	58	54	48	23
		300	(142)	450	(212)	0.044	(11.04)	69	66	65	63	60	57	24	69	66	65	63	60	57	24	71	68	67	64	60	57	27
		375	(177)	575	(271)	0.069	(17.25)	72	70	69	67	65	64	29	72	70	69	67	65	64	29	74	72	71	69	65	64	32
		450	(212)	675	(319)	0.100	(24.85)	75	73	71	70	69	68	33	75	73	71	70	69	68	33	77	75	74	72	69	68	35
3	6	150	(71)	300	(142)	0.011	(2.76)	61	55	55	53	46	42	-	61	55	55	53	46	42	-	61	55	55	53	46	42	-
		225	(106)	450	(212)	0.025	(6.21)	66	60	59	58	53	49	-	66	60	59	58	53	49	-	66	60	59	58	53	49	-
		300	(142)	600	(283)	0.044	(11.04)	70	64	63	62	58	55	24	70	64	63	62	58	55	24	70	64	63	62	58	55	24
		375	(177)	750	(354)	0.069	(17.25)	73	67	65	65	62	59	25	73	67	65	65	62	59	25	73	67	65	65	62	59	25
		450	(212)	900	(425)	0.100	(24.85)	76	69	67	67	65	62	28	76	69	67	67	65	62	28	76	69	67	67	65	62	28
3	8	180	(85)	300	(142)	0.011	(2.76)	61	55	55	53	46	42	-	61	55	55	53	46	42	-	61	55	55	53	46	42	-
		270	(127)	450	(212)	0.025	(6.21)	66	60	59	58	53	49	-	66	60	59	58	53	49	-	66	60	59	58	53	49	-
		360	(170)	600	(283)	0.044	(11.04)	70	64	63	62	58	55	24	70	64	63	62	58	55	24	70	64	63	62	58	55	24
		450	(212)	750	(354)	0.069	(17.25)	73	67	65	65	62	59	25	73	67	65	65	62	59	25	73	67	65	65	62	59	25
		540	(255)	900	(425)	0.100	(24.85)	76	69	67	67	65	62	28	76	69	67	67	65	62	28	76	69	67	67	65	62	28
5	6	100	(47)	500	(236)	0.004	(0.99)	62	57	53	54	48	40	-	62	57	53	54	48	40	-	62	57	53	54	48	40	-
		200	(94)	700	(330)	0.016	(3.98)	67	61	58	59	54	48	-	67	61	58	59	54	48	-	67	61	58	59	54	48	-
		300	(142)	1000	(472)	0.036	(8.94)	71	66	64	65	60	56	23	71	66	64	65	60	56	23	71	66	64	65	60	56	23
		400	(189)	1300	(614)	0.064	(15.90)	75	70	68	69	65	62	27	75	70	68	69	65	62	27	75	70	68	69	65	62	27
		500	(236)	1500	(708)	0.100	(24.85)	77	72	70	71	68	66	30	77	72	70	71	68	66	30	77	72	70	71	68	66	30
5	8	300	(142)	500	(236)	0.011	(2.76)	62	57	53	54	48	40	-	62	57	53	54	48	40	-	62	58	53	54	48	40	-
		420	(198)	700	(330)	0.022	(5.41)	67	61	58	59	54	48	-	67	61	58	59	54	48	-	67	61	58	59	54	48	-
		600	(283)	1000	(472)	0.044	(11.04)	71	66	64	65	60	56	23	71	66	64	65	60	56	23	71	66	64	65	60	56	23
		780	(368)	1300	(614)	0.075	(18.66)	75	70	68	69	65	62	27	75	70	68	69	65	62	27	75	70	68	69	65	62	27
		900	(425)	1500	(708)	0.100	(24.85)	77	72	70	71	68	66	30	77	72	70	71	68	66	30	77	72	70	71	68	66	30
5	10	350	(165)	500	(236)	0.011	(2.76)	62	57	53	54	48	40	-	62	57	53	54	48	40	-	62	58	53	54	48	40	-
		490	(231)	700	(330)	0.022	(5.41)	67	61	58	59	54	48	-	67	61	58	59	54	48	-	67	61	58	59	54	48	-
		700	(330)	1000	(472)	0.044	(11.04)	71	66	64	65	60	56	23	71	66	64	65	60	56	23	71	66	64	65	60	56	23
		910	(429)	1300	(614)	0.075	(18.66)	75	70	68	69	65	62	27	75	70	68	69	65	62	27	75	70	68	69	65	62	27
		1050	(496)	1500	(708)	0.100	(24.85)	77	72	70	71	68	66	30	77	72	70	71	68	66	30	77	72	70	71	68	66	30

NOTES: Discharge sound power is the sound emitted from the unit discharge. All sound data is based on tests conducted in accordance with AHRI 880-11 and corrected for end reflection. ΔPs is the difference in static pressure from inlet to discharge. Sound power levels are in dB, re 10⁻¹² Watts. NC application data is from AHRI Standard 885-08 Appendix E, as a function of flow rate shown. Dash indicates a NC is less than 20. See Krueger's selection software for specific sound data for optional liners; 1/2" dual density shown. See Krueger's Terminal Unit Engineering section for reductions and definitions.

KLPS

© KRUEGER 2012

KLPS-D Radiated Sound Performance Data
KLPS-D, RADIATED SOUND DATA

Unit Size	Inlet Size	Primary Flow Rate		Fan Flow Rate		Min. Δ Ps		Fan Only							Fan + Primary @ 0.75" Δ Ps							Fan + Primary @ 1.5" Δ Ps									
								Octave Band Sound Power, Lw							Lp	Octave Band Sound Power, Lw							Lp	Octave Band Sound Power, Lw							Lp
		CFM	(L/s)	CFM	(L/s)	"WG	(Pa)	2	3	4	5	6	7	NC	2	3	4	5	6	7	NC	2	3	4	5	6	7	NC			
1	4	40	(19)	200	(94)	0.003	(0.74)	47	44	44	40	31	23	18	47	44	44	40	31	23	18	47	44	44	40	31	23	18			
		75	(35)	325	(153)	0.010	(2.60)	55	52	51	47	39	32	25	55	52	51	47	39	32	25	55	52	51	47	39	32	25			
		125	(59)	450	(212)	0.029	(7.21)	60	57	55	51	45	37	30	60	57	55	51	45	37	30	60	57	55	51	45	37	30			
		175	(83)	575	(271)	0.057	(14.14)	64	61	58	55	49	42	33	64	61	58	55	49	42	33	64	61	58	55	49	42	33			
		232	(109)	675	(319)	0.100	(24.85)	66	63	60	57	51	45	35	66	63	60	57	51	45	35	66	63	60	57	51	45	35			
1	5	63	(30)	200	(94)	0.003	(0.75)	47	44	44	40	31	23	18	47	44	44	40	31	23	18	47	44	44	40	31	23	18			
		150	(71)	325	(153)	0.017	(4.24)	55	52	51	47	39	32	25	55	52	51	47	39	32	25	55	52	51	47	39	32	25			
		225	(106)	450	(212)	0.038	(9.55)	60	57	55	51	45	37	30	60	57	55	51	45	37	30	62	60	57	51	45	37	32			
		300	(142)	575	(271)	0.068	(16.97)	64	61	58	55	49	42	33	64	63	60	55	49	42	35	66	64	61	57	49	42	36			
		363	(171)	675	(319)	0.100	(24.85)	66	63	60	57	51	45	35	66	66	63	57	51	45	38	69	68	64	60	53	47	39			
1	6	150	(71)	200	(94)	0.011	(2.76)	47	44	44	40	31	23	18	49	47	46	40	31	23	20	50	49	47	40	31	25	21			
		225	(106)	325	(153)	0.025	(6.21)	55	52	51	47	39	32	25	56	55	53	47	39	32	27	58	56	54	49	39	34	29			
		300	(142)	450	(212)	0.044	(11.04)	60	57	55	51	45	37	30	62	60	57	51	45	37	32	63	62	59	54	47	40	34			
		375	(177)	575	(271)	0.069	(17.25)	64	61	58	55	49	42	33	66	64	61	55	49	42	36	67	66	62	58	51	44	37			
		450	(212)	675	(319)	0.100	(24.85)	66	63	60	57	51	45	35	68	67	63	59	51	45	39	70	69	65	61	54	47	40			
3	6	150	(71)	300	(142)	0.011	(2.76)	61	56	57	57	50	40	31	61	56	57	57	50	40	31	61	56	57	57	50	40	31			
		225	(106)	450	(212)	0.025	(6.21)	62	57	57	58	51	41	32	62	57	57	58	51	41	32	62	57	57	58	51	41	32			
		300	(142)	600	(283)	0.044	(11.04)	62	57	58	58	52	42	33	64	59	60	60	52	43	35	65	60	60	60	52	44	35			
		375	(177)	750	(354)	0.069	(17.25)	63	58	58	59	53	42	33	66	61	61	61	55	45	36	66	61	61	61	55	45	36			
		450	(212)	900	(425)	0.100	(24.85)	63	58	59	59	53	42	34	67	62	62	62	56	46	37	67	62	62	62	56	47	37			
3	8	180	(85)	300	(142)	0.011	(2.76)	61	56	57	57	50	40	31	61	56	57	57	50	40	31	61	56	57	57	50	40	31			
		270	(127)	450	(212)	0.025	(6.21)	62	57	57	58	51	41	32	62	57	57	58	51	41	32	62	57	57	58	51	41	32			
		360	(170)	600	(283)	0.044	(11.04)	62	57	58	58	52	42	33	64	59	60	58	52	44	35	65	60	60	60	54	44	35			
		450	(212)	750	(354)	0.069	(17.25)	63	58	58	59	53	42	33	65	61	61	61	55	45	36	66	61	61	61	55	45	36			
		540	(255)	900	(425)	0.100	(24.85)	63	58	59	59	53	42	34	67	62	62	62	56	47	37	67	62	62	62	57	47	37			
5	6	100	(47)	500	(236)	0.004	(0.99)	58	53	52	48	40	28	26	58	53	52	48	40	31	26	58	53	52	48	40	32	26			
		200	(94)	700	(330)	0.016	(3.98)	62	57	56	52	45	35	30	62	57	56	52	45	37	30	62	57	56	52	45	38	30			
		300	(142)	900	(425)	0.036	(8.94)	64	60	59	55	49	40	34	64	60	59	55	49	40	34	64	60	59	55	49	42	34			
		400	(189)	1100	(519)	0.064	(15.90)	66	62	61	58	52	44	36	66	62	61	58	52	44	36	66	62	61	58	52	44	36			
		500	(236)	1300	(614)	0.100	(24.85)	68	64	63	60	54	48	38	68	64	63	60	54	48	38	68	64	63	60	54	48	38			
5	8	300	(142)	500	(236)	0.013	(3.17)	58	53	52	48	40	28	26	58	53	52	48	40	35	26	58	55	52	48	40	36	26			
		450	(212)	725	(342)	0.027	(6.66)	62	57	56	53	45	36	31	62	57	56	53	45	39	31	62	57	56	53	45	40	31			
		570	(269)	950	(448)	0.046	(11.44)	65	60	59	56	50	41	34	65	60	59	56	50	41	34	65	60	59	56	50	44	34			
		750	(354)	1200	(566)	0.070	(17.50)	67	63	62	59	53	46	37	67	63	62	59	53	46	37	67	63	62	59	53	46	37			
		840	(396)	1400	(661)	0.100	(24.85)	69	65	64	61	56	49	39	69	65	64	61	56	49	39	69	65	64	61	56	49	39			
5	10	350	(165)	500	(236)	0.011	(2.76)	58	53	52	48	40	28	26	58	53	52	48	40	34	26	58	54	52	48	40	35	26			
		500	(236)	750	(354)	0.025	(6.21)	62	58	57	53	46	37	31	62	58	57	53	46	39	31	62	58	57	53	46	40	31			
		700	(330)	1000	(472)	0.044	(11.04)	65	61	60	57	50	43	35	65	61	60	57	50	43	35	65	61	60	57	50	43	35			
		875	(413)	1250	(590)	0.069	(17.25)	68	64	63	60	54	47	38	68	64	63	60	54	47	38	68	64	63	60	54	47	38			
		1050	(496)	1500	(708)	0.100	(24.85)	70	66	65	62	57	51	40	70	66	65	62	57	51	40	70	66	65	62	57	51	40			

NOTES: Radiated sound power is the sound transmitted through the casing walls. All sound data is based on tests conducted in accordance with AHRI 880-11. Sound power levels are in dB, re 10⁻¹² Watts. ΔPs is the difference in static pressure from inlet to discharge. NC application data is from AHRI Standard 885-08 Appendix E. All data points listed are application ratings outside the scope of the Certification Program. See Krueger's selection program for specific sound data for optional liners; 1/2", dual density liner shown. Dash indicates a NC is less than 20. See Krueger's Terminal Unit Engineering section for reductions and definitions.

FAN POWERED TERMINAL UNITS

K L P S

KLPS Control Information**CONTROL SEQUENCE OF OPERATION**

The standard KLPS sequence of operation has the induced airflow fan operating continuously, providing a constant volume of discharge air to the conditioned space.

HEATING MODE

When the zone is at maximum heating demand, the primary air damper maintains a minimum flow and the fan runs constantly, inducing the maximum amount of warm ceiling plenum air. Electric or hot water heat, if supplied, operates at maximum capacity.

As the zone temperature rises, the optional heat, if supplied, cycles off. The fan continues to induce a maximum amount of ceiling plenum air. As the zone temperature rises above the thermostat setpoint, the KLPS unit enters the cooling mode.

COOLING MODE

As the zone temperature rises above setpoint, the primary air damper begins to modulate toward the full open damper position. As the amount of conditioned primary air increases, the amount of induced ceiling plenum air decreases proportionally.

When the conditioned zone is maximum cooling demand, the primary air damper will maintain a constant maximum flow setting. With pressure independent controls, the damper will maintain the maximum flow setting regardless of system pressure fluctuations. The fan will discharge virtually 100% primary air if installed and balanced properly.

NIGHT SETBACK

One of the most popular KLPS control arrangements is the night setback feature. With this control arrangement, the KLPS induced air fan will operate whenever central system pressure is sensed (day mode). When the central system is off (night mode), the KLPS induced air fan and optional heat will cycle on in response to thermostat demand.

CONTROL OPTIONS

- **Pneumatic Controls:** Pressure independent control packages are available with or without hot water or electric heat, night shutdown and/or unoccupied heating. All control arrangements include an inlet flow sensor and fan speed controller.
- **Analog Controls:** Pressure independent control packages are available with or without hot water or electric heat, automatic or remote night shutdown and automatic night setback. All control arrangements include an inlet flow sensor, control enclosure, fan speed controller, transformer to 24 volts, and wall thermostat to match the control type.
- **Direct Digital Controls:** Smart Equipment control packages are provided and programmed by the factory for in-house mounting, piping, and wiring.
 - BACnet Compatible: 7201-7209
 - Standalone: 6201-6209

Other digital control packages can be supplied to the factory for mounting, piping, and wiring.

Contact your Krueger representative for a complete list of direct digital control arrangements.

- **No Control Unit:** Units are factory supplied without controls, assuming that the unit is being used for field mounting of direct digital control equipment. This arrangement includes an inlet flow sensor, control enclosure, fan speed controller, transformer to 24 volts, and fan relay.

NOTES: Visit Krueger's website at www.krueger-hvac.com or contact your local Krueger representative for a complete list of direct digital control arrangements.

To prevent the blower from spinning backwards, the simplest solution is to require that the building control system energize the series box fans prior to starting the central system air handler. Some DDC controls for series boxes have a start-up procedure that closes the damper, de-energizes the fan, (resets to zero on the pressure transducer while the damper is closed) and then returns control to the unit. Most manufacturers' Series Fan boxes are designed to maximize starting torque to overcome this backward rotation. If, however, the primary airflow is available for long enough, and the fan speed control is set at a low enough value, any series fan terminal can be expected to start and operate backward. This will not damage the unit, and it will deliver approximately 60% of designed airflow. Until the space load exceeds 60% of the design load, it is probable that no one will notice the unit is running backward. When the thermostat calls for more than 60% of the design load the excess primary will spill into the plenum and the likely result will be cold plenum air 'falling' from return grilles onto room occupants. No manufacturer offers a mechanical device to prevent backward rotation. Krueger can supply a special sequence that employs a pressure sensor installed in the high-pressure side of the inlet sensor to detect any airflow in the primary duct and energize the fan if the building's control system cannot be properly configured to avoid this problem.

KLPS Control Information

The following list shows the standard control arrangements available with the KLPS product offering. Each control approach offers a variety of pressure independent operating functions; combinations of control functions are identified by the Krueger control package number.

PNEUMATIC CONTROL ARRANGEMENTS

- 1300 - Single Function Controller; DA-NO with or without Hot Water or Electric Heat
- 1301 - Single Function Controller; DA-NO with or without Hot Water or Electric Heat and with Night Shutdown
- 1302 - Single Function Controller; DA-NO with or without Hot Water or Electric Heat, with Night Shutdown, and Unoccupied Heating
- 1303 - Single Function Controller; RA-NC with or without Hot Water or Electric Heat
- 1304 - Single Function Controller; RA-NC with or without Hot Water or Electric Heat and with Night Shutdown
- 1305 - Single Function Controller; RA-NC with or without Hot Water or Electric Heat, with Night Shutdown and Unoccupied Heating
- 1306 - Multi-function Controller; DA-NO with or without Hot Water or Electric Heat
- 1307 - Multi-function Controller; DA-NO with or without Hot Water or Electric Heat and with Night Shutdown
- 1308 - Multi-function Controller; DA-NO with or without Hot Water or Electric Heat, with Night Shutdown and Unoccupied Heating
- 1309 - Multi-function Controller; DA-NC with or without Hot Water or Electric Heat
- 1310 - Multi-function Controller; DA-NC with or without Hot Water or Electric Heat and with Night Shutdown
- 1311 - Multi-function Controller; DA-NC with or without Hot Water or Electric Heat, with Night Shutdown and Unoccupied Heating
- 1312 - Multi-function Controller; RA-NC with or without Hot Water or Electric Heat
- 1313 - Multi-function Controller; RA-NC with or without Hot Water or Electric Heat and with Night Shutdown
- 1314 - Multi-function Controller; RA-NC with or without Hot Water or Electric Heat, with Night Shutdown and Unoccupied Heating
- 1315 - Multi-function Controller; RA-NO with or without Hot Water or Electric Heat
- 1316 - Multi-function Controller; RA-NO with or without Hot Water or Electric Heat and with Night Shutdown
- 1317 - Multi-function Controller; RA-NO with or without Hot Water or Electric Heat, with Night Shutdown and Unoccupied Heating

Pneumatic Control Legend:

- DA - Direct Acting Thermostat
- RA - Reverse Acting Thermostat
- NO - Normally Open Damper Position
- NC - Normally Closed Damper Position
- Single Function Controller - Provides Single Function, DA-NO or RA-NC
- Multi-function Controller - Capable of Providing DA-NO, DA-NC, RA-NC or RA-NO Functions

ANALOG CONTROL ARRANGEMENTS

- 2200 - Cooling Only
- 2201 - Cooling Only with Automatic Night Shutdown
- 2203 - Cooling Only with Automatic Night Setback
- 2204 - Cooling with On/Off Hot Water Heat
- 2205 - Cooling with On/Off Hot Water Heat and Automatic Night Shutdown
- 2207 - Cooling with On/Off Hot Water Heat and Automatic Night Setback
- 2208 - Cooling with Proportional Hot Water Heat
- 2209 - Cooling with Proportional Hot Water Heat and Automatic Night Shutdown
- 2211 - Cooling with Proportional Hot Water Heat and Automatic Night Setback
- 2212 - Cooling with Up to Two Stages of Electric Heat
- 2213 - Cooling with Up to Two Stages of Electric Heat and Automatic Night Shutdown
- 2215 - Cooling with Up to Two Stages of Electric Heat and Automatic Night Setback
- 2217 - Cooling/heating with Automatic Changeover
- 2218 - Cooling with Proportional Electric Heat

DIRECT DIGITAL CONTROL ARRANGEMENTS

Visit Krueger's website at www.krueger-hvac.com or contact your Krueger representative for a complete list of factory mounted direct digital control arrangements.

KLPS, KLPS-D Engineering Specification & Configuration**KLPS UNIT**

Fan powered terminal unit size 1 shall be ultra low profile not exceeding 8 5/8" in height or 48" in length, or unit sizes 2 - 4 shall be a low profile type not exceeding 11" in height and 41" in length, or unit size 5 shall be a low profile type unit not exceeding 17" in height and 47" in length, completely factory assembled and wired with motor, blower, mixing plenum, and primary air damper contained in a single unit housing. Unit shall be Krueger model KLPS.

The induced air fan shall operate continuously during central system operation. Primary airflow controller shall compensate for central system pressure fluctuations. When room temperature requires maximum heating, the (direct digital) (analog) (pneumatic) pressure independent velocity controller maintains the minimum primary airflow setting by modulating the damper. The electric heating coil or hot water coil, if supplied, is energized (activated). As room temperature begins to rise, the heating coil is de-energized (deactivated). As room temperature rises above the setpoint, the primary air damper will modulate to maintain room temperature. When the room temperature calls for maximum cooling, the velocity controller maintains the maximum primary airflow setting.

To prevent the fan/motor from running in the backward direction, the unit induced air fan shall be field wired so that it is electrically or pneumatically interlocked with the central system fan.

Terminals shall be tested by use of the AHRI Standard 880. The terminal unit shall be ETL listed as a complete assembly. All electrical components shall be UL listed and installed in accordance with the National Electric Code. All electrical components shall be mounted in sheet metal control enclosures. Electrical connection shall be single point.

Unit casing shall be constructed of not less than 20 gage galvanized steel. Unit discharge shall be rectangular, suitable for flanged duct connections.

Unit labels shall be adhered to each unit including model size, airflow (CFM), balancing chart, and tagged data.

KLPS unit shall be equipped with a factory installed airflow sensing device. Provide a K4 LineaCross, four quadrant, multi-point center averaging sensor with an amplified signal.

- **(Optional)** Provide a linear, multi-point, velocity averaging sensor with an amplified signal.

Provide balancing taps to allow for easy airflow verification.

Fan motor and all interior components must be accessible through a removable bottom access panel.

Fan shall be of the forward curve, centrifugal type. The fan motor shall be single speed (120, 208/240, 277), 60 cycle, single phase, energy efficient design, permanently lubricated, using permanent split capacitor for starting and be specifically designed for use with an SCR fan speed controller. Motor must have thermal overload protection. The fan motor shaft shall be connected directly to the fan and fan motor shall be isolated from the unit casing to prevent transmission of vibration.

- **(Optional)** ECM Fan Motor: The fan motor shall be [120, 208/240, or 277 volt, single-phase] ECM (electronically commutated motor) fan motors including either a manual or remote adjustable speed controller. The manual adjustable speed controller is field set with a digital display, alternating between RPM and percentage full airflow. The remote adjustable speed controller provides a means to remotely set and/or adjust the fan speed.

The radiated and discharge attenuation factors for the specified NC levels shall be based on attenuation factors from AHRI Standard 885-08 Appendix E, which includes room absorption, environmental adjustment factor, duct insertion, end reflection and duct branching.

Unit casing shall be lined with 1/2" thick, 1 1/2 lb. dual density fiberglass insulation that meets UL 181 and NFPA 90A. Insulation shall be attached to the unit casing by adhesive and weld pins.

- **(Optional)** Cellular Insulation; Unit casing shall be lined with 1/2" or 1" (size 5 only) thick, 1 1/2 lb. density, smooth surface, polyolefin, closed-cell, foam insulation for fiber free application. Cellular insulation meets UL 181 and NFPA 90A and does not support mold or bacteria growth. Insulation shall be attached to the unit casing by adhesive and weld pins.
- **(Optional)** Sterilwall Insulation: Unit casing shall be lined with 1/2", 1 1/2 lb. dual density fiberglass insulation that meets UL 181 and NFPA 90A, enclosed between the unit casing and a non-perforated internal sheet metal cover

extending over the fiberglass insulation, as well as covering the liner cut edges.

- **(Optional)** Perforated Doublewall Insulation: Unit casing shall be lined with 1/2", 1 1/2 lb. dual density fiberglass insulation that meets UL 181 and NFPA 90A, enclosed between the unit casing and a perforated internal sheet metal cover extending over the fiberglass insulation, as well as covering the liner cut edges.
- **(Optional)** Foil Encapsulated Insulation: Unit casing shall be lined with foil reinforced, wrapped edges, 1/2" or 1" (size 5 only) thick, 1 1/2 lb. density fiberglass insulation that meets UL 181 and NFPA 90A. Insulation shall be attached to the unit casing by adhesive and weld pins.
- **(Optional - Unit Size 5 Only)** Steriliner Insulation: Unit casing shall be lined with 13/16" thick, 4 lb. density, rigid board insulation with fiber reinforced foil covering insulation fibers that meets UL 181 and NFPA 90A. Liner shall be attached to unit casing by adhesive and weld pins with foil tape sealing the insulation cut edges.
- **(Optional - Unit Size 5 Only)** 1" Thick Insulation: Unit casing shall be lined with 1" thick, 1 1/2 lb. dual density fiberglass insulation that meets UL 181 and NFPA 90A. Insulation shall be attached to the unit casing by adhesive and weld pins.
- **(Optional)** No Liner: Unit casing shall be equipped with no internal insulation liner.

ELECTRIC HEAT COILS

Electric coils shall be supplied by the terminal unit manufacturer and shall be ETL listed in accordance with UL standards. Construct coil casing with minimum of 20 gage galvanized steel. Elements shall be 80/20 Ni-Cr and supported by ceramic insulators. The integral control panel shall be housed in a NEMA 2 enclosure with hinged access door for access to all controls and safety devices.

Electric coils shall contain a primary automatic reset thermal cutout and differential pressure airflow switch for proving of airflow.

- **(Optional)** Electric coils shall include fused or non-fused door interlocking disconnect switch, AC solid state relay, fuse-block, manual reset cutout, and/or dust tight enclosure construction.
- **(Optional)** LineaHeat solid state electronic proportional control of electric heat shall meet the requirements of ASHRAE Standard 62, Addenda N.

KLPS, KLPS-D Engineering Specification & Configuration

- **(Optional)** LineaHeat solid state electronic controlled heater with control of the leaving air temperature limiting the unit discharge temperature to a set value.

HOT WATER COILS

Hot water coil casing shall be constructed with minimum 20 gage galvanized steel with flanged discharge for attachment to downstream ductwork. Coils shall be factory installed on the terminal unit. Fins shall be rippled and corrugated heavy gage aluminum, mechanically bonded to

tubes. Tubes shall be copper with minimum wall thickness of 0.016" and with male solder header connections. Coils shall be leak tested to 400 psi. Number of coil rows and circuits shall be selected to provide performance as required by the plans. Coil performance data shall be based on tests run in accordance with AHRI Standard 410.

SENSIBLE COOLING COIL (KLPS-D)

Cooling water coil casing shall be constructed with minimum 18 gage galvanized steel with filter frame to accept 1" construction type or MERV 8 filter. Coils

shall be factory installed on the induced air inlet of terminal unit. Fins shall be rippled and corrugated heavy gage aluminum, mechanically bonded to tubes. Tubes shall be copper with minimum wall thickness of 0.016" and with male solder header connections. Coils shall be leak tested to 400 psi. Number of coil rows and circuits shall be selected to provide performance as required by the plans. Coil performance data shall be based on tests run in accordance with AHRI Standard 410.

1. SERIES: (XXXXX)

- KLPS - Low Profile Fan Powered Terminal Unit
- KLPS-D - Low Profile Fan Powered Terminal Unit, Dedicated Outdoor Air System

2. SENSOR TYPE: (X)

- 1 - Linear Averaging
- 3 - K4 LineaCross (Four Quadrant)

3. LINER TYPE: (X)

- 0 - 1/2" Liner
- 1 - 1" Liner ^
- 2 - Steriliner ^
- 3 - No Liner ^
- 4 - Sterilwall with 1/2" Dual Density
- 6 - 1/2" Foil Encapsulated
- 9 - 1" Foil Encapsulated ^
- A - Perforated Doublewall with 1/2" Dual Density
- F - 1/2" Cellular
- H - 1" Cellular ^

4. UNIT CASING CONTROLS: (XX)

- 1L - Left-hand Side, 20 Gage
- 1R - Right-hand Side, 20 Gage
- 2L - Left-hand Side, 20 Gage, Dual Access Panels
- 2R - Right-hand Side, 20 Gage, Dual Access Panels

5. UNIT SIZE: (X)

- 1 - Inlet Sizes: 4", 5", 6", 7"
- 2 - Inlet Sizes: 4", 5", 6", 7", 8"
- 3 - Inlet Sizes: 4", 5", 6", 7", 8", 10"
- 4 - Inlet Sizes: 10", 8" x 14"
- 5 - Inlet Sizes: 6", 7", 8", 10", 12", 14"

6. INLET CODE: (XX)

- 04 - 4" Round 05 - 5" Round
- 06 - 6" Round 08 - 8" Round
- 10 - 10" Round 12 - 12" Round
- 14 - 14" Round
- 12 - 8" x 14" Rectangle ^^^

7. MOTOR VOLTAGE: (X)

- 1 - 120V, 1-Phase
- 2 - 208/240V, 1-Phase
- 3 - 277V, 1-Phase
- 4 - ECM Motor, 120V, 1-Phase **
- 5 - ECM Motor, 208/240V, 1-Phase **
- 6 - ECM Motor, 277V, 1-Phase **

8. CONTROL TYPE: (XXXX)

- (2XXX) - Analog
- (7XXX) - Digital, BACnet Compatible
- (6XXX) - Digital, Standalone
- (XXXX) - Factory Mounted, Provided by Others
- (1XXX) - Pneumatic

9. UNIT ACCESSORIES: (Up to 6)

- 0 - None
- A - Motor Toggle Disconnect *
- F - Fan Motor Fuse
- P - Cam Lock for Access Panels ^^
- R - Induction Inlet Filter, Construction Type
- S - Hanger Brackets
- 1 - 2 Row Cooling Coil, Upstream Piping Connection *
- 2 - 2 Row Cooling Coil, Downstream Piping Connection *
- 3 - 4 Row Cooling Coil, Upstream Piping Connection *
- 4 - 4 Row Cooling Coil, Downstream Piping Connection *
- 5 - 6 Row Cooling Coil - Upstream Piping Connection *
- 6 - 6 Row Cooling Coil - Downstream Piping Connection *
- M - MERV 8 Filter **

10. WATER HEAT: (ROWS/CONNECTION HAND) (XXX)

- 000 - N/A / None
- W11 - 1 Row/Right
- W12 - 2 Row/Right
- W21 - 1 Row/Left
- W22 - 2 Row/Left

11. ELECTRIC HEAT: (XX)
LINEAHEAT: (XX)

- 00 - None
- E1 - 120v/1-Phase
- E2 - 208v/1-Phase
- E3 - 240v/1-Phase
- E4 - 277v/1-Phase
- E6 - 208v/3-Phase/3-Wire
- E9 - 480v/3-Phase/4-Wire
- L1 - 120v/1-Phase
- L2 - 208v/1-Phase
- L3 - 240v/1-Phase
- L4 - 277v/1-Phase
- L6 - 208v/3-Phase/3-Wire
- L9 - 480v/3-Phase/4-Wire

12. ELECTRIC HEAT STEPS: (X)

- 0 - None
- 1 - 1-Stage
- 2 - 2-Stage
- 3 - 3-Stage

13. HEAT COIL ACCESSORIES: (X) (X) (X) (X)

- 0 - None
- C - Fuse Block
- F - Manual Reset Cutout
- G - Dust-tight Construction
- H - Staged Solid State Relays
- K - Door-interlocking Fused Disconnect
- L - Door-interlocking Non-fused Disconnect

* Motor Toggle Disconnect not available with electric heat.

** Manual or remote adjustable speed controller for ECM motor option is required.

^ Liner Available on unit size 5 only.

^^ Cam Locks ONLY available with casing configurations 2R' & '2L'.

^^^ KLPS Size 4 Only.

* Available on KLPS-D only.

** Available with ECM Motor only.

SAMPLE CONFIGURATION: KLPS - 1 - 0 - 1L - 3 - 08 - 2 - 6208 - 0 - 0 - 0 - 0 - W12