

QFV | Standard, Parallel Flow

QFV Unit with Electric Heat Dimensional Information

QFV UNIT WITH ELECTRIC HEAT, INLET, PLAN, AND DISCHARGE VIEWS

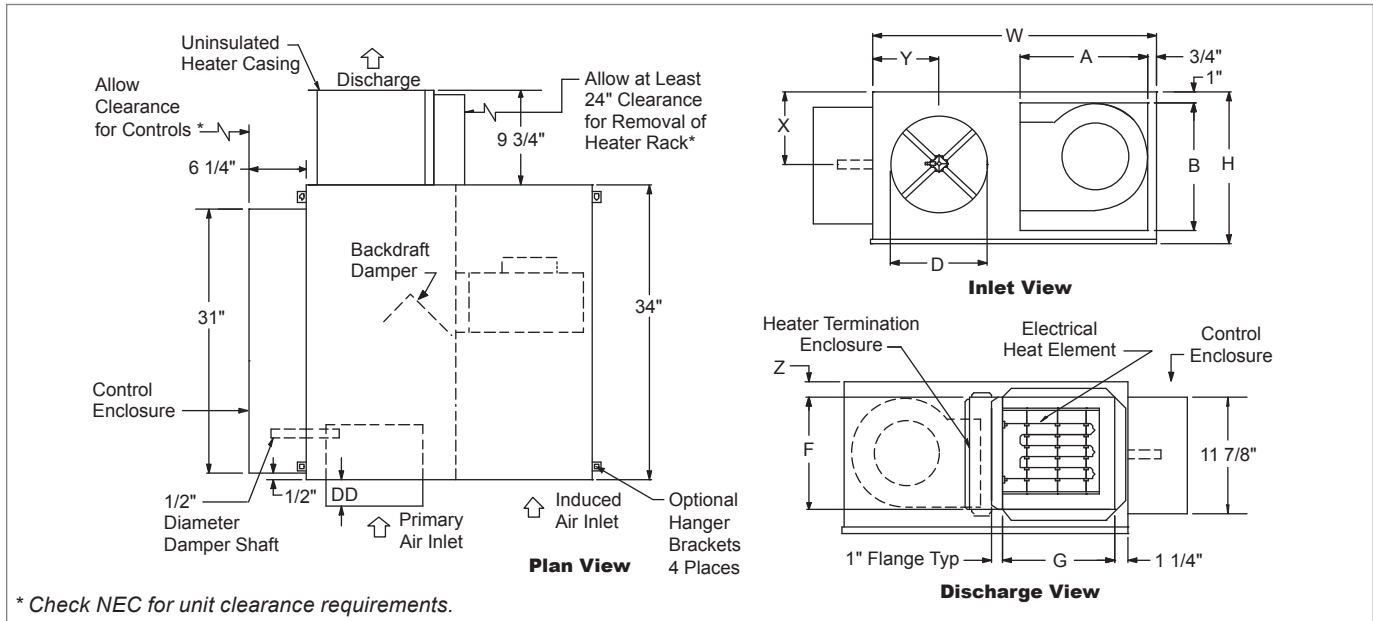

* Check NEC for unit clearance requirements.

QFV UNIT WITH ELECTRIC HEAT, DIMENSIONAL DETAILS

Unit Size	Inlet Size	Max. Primary CFM	Max. Fan CFM	PSC HP	W	H	Induced Air		D	Discharge		X	Y	Z
							A	B		F	G			
2	06	515	400	1/10	29"	15"	13"	13"	5 7/8"	11 1/2"	11 1/2"	7 1/2"	6 7/8"	1 3/4"
2	08	920	400	1/10	29"	15"	13"	13"	7 7/8"	11 1/2"	11 1/2"	7 1/2"	6 7/8"	1 3/4"
3	08	920	600	1/10	29"	15"	13"	13"	7 7/8"	11 1/2"	11 1/2"	7 1/2"	6 7/8"	1 3/4"
3	10	1430	600	1/10	29"	15"	13"	13"	9 7/8"	11 1/2"	11 1/2"	7 1/2"	6 7/8"	1 3/4"
4	10	1430	1050	1/4	29"	15"	13"	13"	9 7/8"	11 1/2"	11 1/2"	7 1/2"	6 7/8"	1 3/4"
4	12	2060	1050	1/4	29"	15"	13"	13"	11 7/8"	11 1/2"	11 1/2"	7 1/2"	6 7/8"	1 3/4"
5	12	2060	1500	1/2	37"	17 3/4"	17"	15 3/4"	11 7/8"	14"	15 1/2"	8 7/8"	8"	1 7/8"
5	14	2800	1500	1/2	37"	17 3/4"	17"	15 3/4"	13 7/8"	14"	15 1/2"	8 7/8"	9"	1 7/8"
6	14	2800	1800	1/2	37"	17 3/4"	17"	15 3/4"	13 7/8"	14"	15 1/2"	8 7/8"	9"	1 7/8"
6	16	3660	1800	1/2	37"	17 3/4"	17"	15 3/4"	15 7/8"	14"	15 1/2"	8 7/8"	9"	1 7/8"
7	16	3660	2200	3/4	37"	17 3/4"	17"	15 3/4"	15 7/8"	14"	15 1/2"	8 7/8"	9"	1 7/8"

NOTES: Unit available as left-hand primary air configuration only. See next page for electric heat standard features.

QFV Unit with Electric Heat Features & Options

STANDARD FEATURES

- 22 Gage galvanized steel casing construction.
- Control enclosure for electronic components.
- 1/2" Thick, Dual density fiberglass insulation that meets NFPA 90A and UL 181 safety requirements.
- [120, 208/240, or 277 volt, multi-voltage, single-phase, single-speed] permanently lubricated PSC motors.
- Field adjustable fan speed control.
- Removable bottom panel allows easy access to all internal components for maintenance.
- Four quadrant center averaging airflow sensor; inlet sizes 6 - 10 (DD = 4 7/8"); sizes 12 - 16 (DD = 6 7/8").
- Flange discharge connection on electric heat coil.
- Single point electrical connection.
- Includes 24 volt control transformer.
- ETL listed; adherence to UL 1995 and CSA C22.2 No. 236.95.
- AHRI certified sound ratings.

OPTIONAL FEATURES

- 20 Gage galvanized steel casing construction.
- LineaHeat solid state electronic proportional control of electric heat.
- Liners: 1/2" or 1" Cellular insulation, 1" Dual density fiberglass insulation, or 1/2" or 1" Foil encapsulated fiberglass insulation.
- Linear averaging airflow sensor; inlet sizes 6 - 10 (DD = 4 7/8"), sizes 12 - 16 (DD = 6 7/8").
- Fused or non-fused door interlocking disconnect.
- Hanger brackets.
- Induced air filter, construction type; unit sizes 2 - 4 (15"x15"x1"); unit sizes 5 - 7 (19"x17"x1").
- Induced air inlet attenuator.
- Manual reset cutout.
- Dust tight control enclosure.
- Motor fusing.
- AC solid state relay.
- Fuse-block.

FAN POWERED TERMINAL UNITS

Q F V

© KRUEGER 2012

QFV Electric Heat Features & Capacities

The kW charts below indicates the maximum and minimum safe limit capacities for each of the QFV units and has been specifically designed for Krueger fan powered terminals. For safe operation, the electric heater controls are interlocked with the airflow proving switch to allow the heater to energize only after the fan is running. Each terminal unit has been tested by ETL in accordance with UL standards.

ELECTRIC HEAT STANDARD FEATURES

- 20 Gage galvanized steel casing construction.
- Line voltage combinations:
[120, 208/240, or 277 volt, single-phase]
[208 volt, three-phase, three-wire]
[480 volt, three-phase, four-wire]
- NEMA 2 electric heat control enclosure.
- Control transformer for analog and direct digital controls.
- Flanged discharge for field duct connection.
- Single point connection between the heater and the fan motor (see combinations below).
- 80/20 Ni-Cr heating elements.
- Automatic reset thermal cutout.
- Magnetic contactors.
- Positive pressure airflow switch.

NOTE: A minimum of 0.1" w.g. downstream static pressure is required in the duct to ensure proper operation.

OPTIONAL HEATER CONTROL

- LineaHeat solid state electronic proportional control of electric heat is available with or without leaving air temperature control. See Krueger's Terminal Unit Engineering section for additional information.
- AC solid state relays offer silent operation for staged electric heat.

SINGLE POINT CONNECTION COMBINATIONS

ELECTRIC HEATER/FAN MOTOR

- [120, 208/240 or 277 volt, single-phase] electric heat includes fan motor wired with same line voltage.
- [208/240 volt, three-phase, three-wire] electric heat utilizes a 208/240 volt, single-phase fan motor.
- [480 volt, three-phase, four-wire] electric heat is equipped with 277 volt, single-phase fan motor.

$$kW = \frac{CFM \times \Delta T (^{\circ}F)}{3160}$$

CALCULATING ELECTRIC HEATER AMPERES

$$\text{Single Phase Amperes} = \frac{\text{Watts}}{\text{Line Voltage}}$$

$$\text{Three Phase Amperes} = \frac{\text{Watts}}{\text{Line Voltage} \times 1.73}$$

NOTES: When selecting electric heaters, do not exceed 120°F discharge air temperature, per NEC. The ASHRAE Handbook of Fundamentals states that discharge temperatures in excess of 90°F are likely to result in objectionable air temperature stratification in the space. Also, ventilation short circuiting may occur. ASHRAE Standard 62 now limits discharge temperatures to 90°F or increasing the ventilation rate when heating from the ceiling.

QFV MINIMUM kW

Unit Sizes	1 Phase				3 Phase				
	120 Volt	208 Volt	240 Volt	277 Volt	208 Volt	480 Volt	5-7		
Stage 1	0.5	0.5	1	0.5	1	1	1.5	2.5	2
Stage 2	1	1	1.5	1	1.5	1.5	1.5	2.5	2
Stage 3	1.5	1.5	2	1.5	2.5	2	1.5	2.5	2

QFV MAXIMUM kW

Unit Size	1 Phase				3 Phase	
	120 Volt	208 Volt	240 Volt	277 Volt	208 Volt	480 Volt
2	4.0	4.0	4.0	4.0	4.0	4.0
3	5.5	6.0	6.0	6.0	6.0	6.0
4	5.0	6.0	6.0	6.0	6.0	6.0
5	4.5	9.0	9.0	12.0	12.0	12.0
6	4.5	8.5	8.5	12.0	14.0	14.0
7	4.5	8.5	8.5	12.0	15.0	18.0

NOTES: Minimum and maximum values apply to staged heaters only. Contact your local Krueger representative for LineaHeat limits.