

HORIZONTAL LENGTH (L): _____
 VERTICAL HEIGHT (H): _____
 DUCT DIAMETER (D): _____

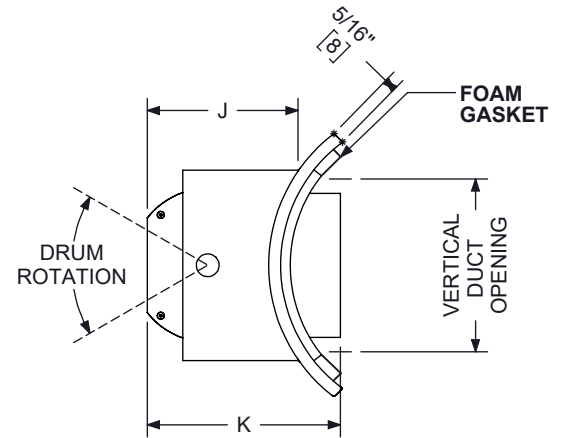

LISTED SIZE (L)	A	BLADE QTY	MOUNTIN G HOLE QTY
12	14 7/8 [378]	3	6
18	20 7/8 [530]	5	8
24	26 7/8 [683]	7	10
30	32 7/8 [835]	9	12
36	38 7/8 [987]	11	14
42	44 7/8 [1140]	13	16
48	50 7/8 [1292]	15	18
60	62 7/8 [1597]	19	20

STANDARD FEATURES :

1. HEAVY GAGE ALUMINUM CONSTRUCTION
2. SEE PAGE 3 FOR AVAILABLE DUCT DIAMETERS
3. FOAM GASKET TO SEAL UNIT TO DUCT
4. ALL UNITS INCLUDE MOUNTING SCREWS
5. STANDARD FINISH IS 10 - ALUMICAN. OTHER FINISHES AVAILABLE

OPTIONAL DAMPER/EXTRACTOR:

SEE PAGE 2

LISTED SIZE (H)	B (MAX)	C	D	J	K
4	6 1/2 [165]	3 [76]	2 3/8 [60]	3 15/16 [100]	5 1/16 [129]
6	8 1/2 [216]		3 3/8 [86]	4 3/16 [106]	5 1/4 [133]
8	10 1/2 [267]		4 3/8 [111]	5 5/8 [143]	7 3/4 [197]
10	12 1/2 [317]	5 [127]	5 7/8 [149]	7 1/8 [181]	8 3/16 [208]
12	14 1/2 [368]		6 7/8 [175]	7 13/16 [198]	8 7/8 [228]
15	17 1/2 [444]		9 13/16 [249]	8 7/16 [214]	9 1/2 [241]

FINISH:

- 10 - ALUMICAN
- 44 - BRITISH WHITE
- 01 - MILL
- 35 - BLACK
- 49 - OFF WHITE
- 07 - ENAMEL PAINT MATCH
- 09 - EPOXY PAINT MATCH

DIMENSION ARE GIVEN AS INCHES [MM]

Revision Date: 4/24/2024

Form: GRS1201.1

Replaces: GRS1201

Product Information is Subject to Change Without Notice

DMDR-OBD (DOBHD)

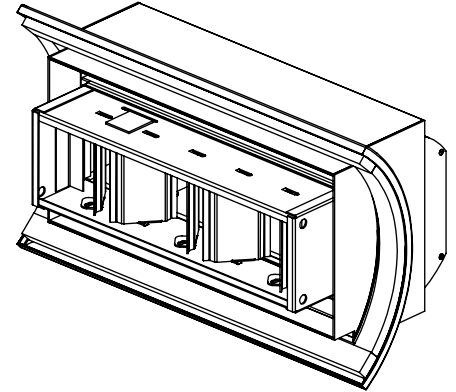
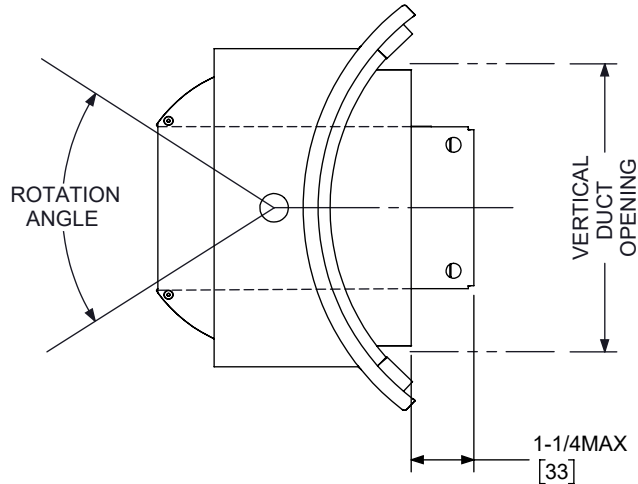

LISTED SIZE (H)	ROTATION ANGLE	
	WITH DAMPER	WITHOUT DAMPER
4	N/A	30
6	19	27
8	18	26
10	27	27
12	26	26
15	27	27

NOTES :

1. DOBHD IS HEAVY DUTY STEEL CONSTRUCTION
2. DAMPER SLOT OPERATOR IS ACCESSIBLE THROUGH THE FACE OF THE DPL UNIT
3. STANDARD FINISH IS #10 ALUMICAN. DMDR AND DAMPER WILL SHARE COMMON FINISH AS SPECIFIED ON ORDER.

DMDR-EXTRACTOR

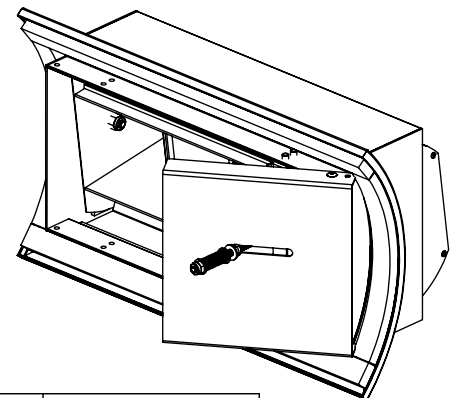
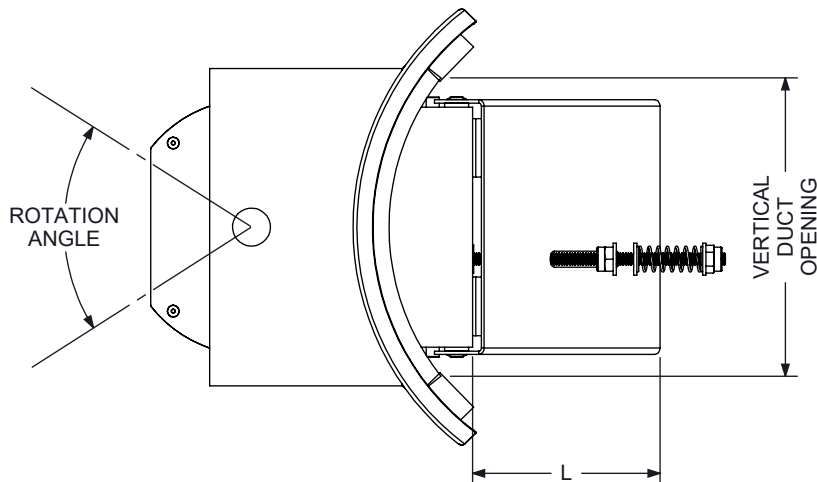

LISTED SIZE (H)	L (MAX)
4	3 3/8 [86]
6	4 1/16 [102]
8	5 6/16 [136]
10	6 11/16 [169]
12	7 15/16 [202]
15	10 11/16 [271]

NOTES :

1. 18 GAUGE GALVANIZED STEEL CONSTRUCTION
2. MUST BE ORDERED WITH UNIT. CANNOT BE FIELD INSTALLED.

DIMENSION ARE GIVEN AS INCHES [MM]

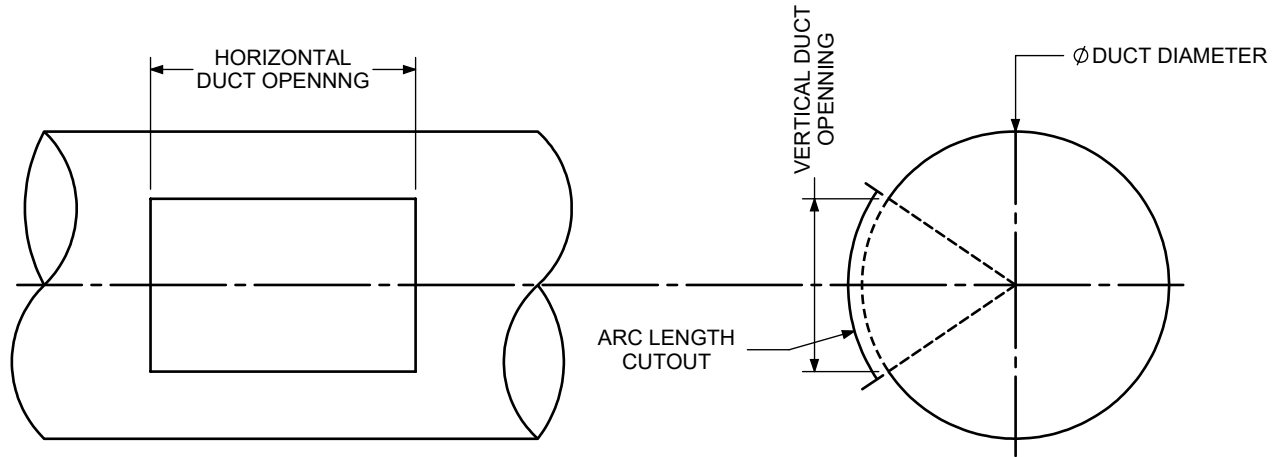

LISTED SIZE (L)	HORIZONTAL DUCT OPENNING
12	12.50
18	18.50
24	24.50
30	30.50
36	36.50
42	42.50
48	48.50
60	60.50

LISTED SIZE (H)	ALLOWABLE DUCT DIAMETERS	VERTICAL DUCT OPENNING	ARC LENGTH CUTOUT
4	8	4.5	4.75
	10	4.5	4.69
	12	4.5	4.63
	14	4.5	4.56
	16	4.5	4.56
	18	4.5	4.56
	20	4.5	4.56
	22	4.5	4.56
	24	4.5	4.50
	26	4.5	4.50
	28	4.5	4.50
	30	4.5	4.50
	32	4.5	4.50
	34	4.5	4.50
36	4.5	4.50	
6	10	6.5	7.06
	12	6.5	6.88
	14	6.5	6.75
	16	6.5	6.69
	18	6.5	6.63
	20	6.5	6.63
	22	6.5	6.63
	24	6.5	6.56
	26	6.5	6.56
	28	6.5	6.56
	30	6.5	6.56
	32	6.5	6.56
34	6.5	6.56	
36	6.5	6.56	
8	14	8.5	9.13
	16	8.5	8.94
	18	8.5	8.88
	20	8.5	8.75
	22	8.5	8.75
	24	8.5	8.69
	26	8.5	8.69
	28	8.5	8.63
	30	8.5	8.63
	32	8.5	8.63
	34	8.5	8.56
	36	8.5	8.56
10	14	10.5	11.88
	16	10.5	11.44
	18	10.5	11.19
	20	10.5	11.06
	22	10.5	10.94
	24	10.5	10.88
	26	10.5	10.81
	28	10.5	10.75
	30	10.5	10.75
	32	10.5	10.69
34	10.5	10.69	
36	10.5	10.63	
12	18	12.5	13.81
	20	12.5	13.50
	22	12.5	13.31
	24	12.5	13.13
	26	12.5	13.06
	28	12.5	12.94
	30	12.5	12.88
	32	12.5	12.81
	34	12.5	12.81
	36	12.5	12.75
15	28	15.5	16.44
	30	15.5	16.31
	32	15.5	16.19
	34	15.5	16.13
	36	15.5	16.00

DIMENSION ARE GIVEN AS INCHES [MM]

Revision Date: 4/24/2024

Form: GRS1201.1

Replaces: GRS1201

Product Information is Subject to Change Without Notice