

LMHS-VP

LOW PROFILE SINGLE DUCT TERMINAL UNIT WITH HOT WATER COIL AND VALVE PACKAGE, NO CONTROLS

SUBMITTAL SHEET

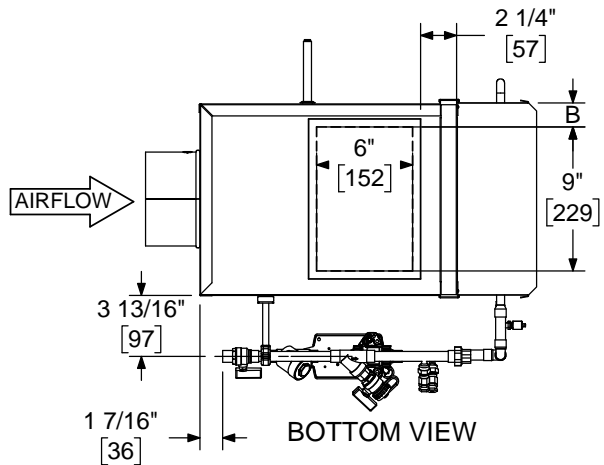
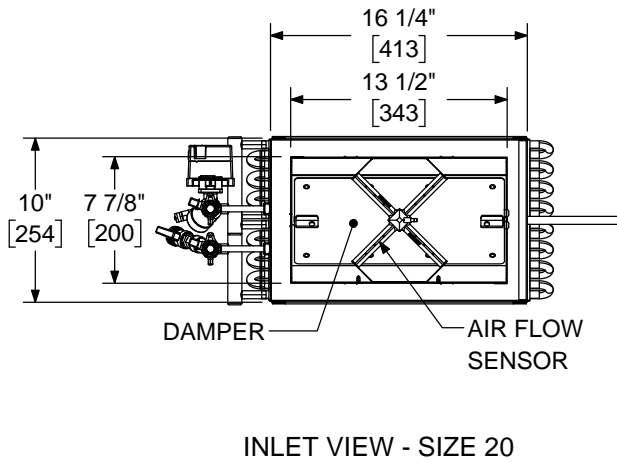
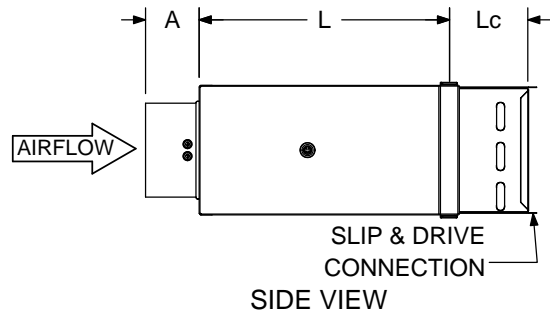
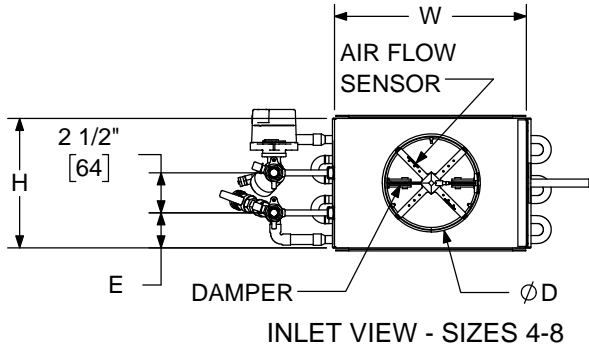

STANDARD FEATURES:

- 22 Ga. Zinc coated steel construction
- 1/2" dia shaft extending from the unit casing
- 1/2" thick dual density fiberglass insulation meeting **NFPA 90A** and **UL 181** safety requirements
- Four quadrant averaging flow sensor
- Hot water coils. See form TUS33-ACC-WH00 for dimensions and specifications
- Field installation of controls
- AHRI 880 certified sound ratings
- 2-way and 3-way valve package available. See form TUS33-ACC-00001 & TUS33-ACC-00002

OPTIONAL FEATURES:

- Liners:
 - 1" dual density fiberglass
 - 1/2" Cellular insulation
 - 1" Cellular insulation
 - Sterilwall w/ 1" fiberglass
 - Perf. Double Wall w/ 1" fiberglass
 - Steriliner
 - None
- 20 Ga. Zinc coated steel construction
- Linear averaging sensor
- 2-Way valve package
- 3-Way valve package
- Left hand control
- Right hand control
- Bottom access panel
- Cam lock bottom access panel
- Manual Damper Control
- Hanger brackets

NOTE: Right hand control configuration shown, left hand available. Coil connection is always opposite of control handing.

DIMENSIONS ARE GIVEN AS INCHES [MM]

INLET SIZE	NOM MAX CFM [L/s]	L	W	H	A	B	D	E	Lc
4	230 [109]	15 1/2 [394]	12 [305]	8 [203]	5 3/8 [136]	1 1/2 [38]	3 7/8 [98]	2 3/16 [56]	SEE FORM TUS33-ACC- WH00
5	360 [170]	15 1/2 [394]	12 [305]	8 [203]	5 3/8 [136]	1 1/2 [38]	4 7/8 [124]	2 3/16 [56]	
6	515 [243]	15 1/2 [394]	12 [305]	8 [203]	3 3/8 [86]	1 1/2 [38]	5 7/8 [149]	2 3/16 [56]	
7	700 [330]	15 1/2 [394]	12 [305]	10 [254]	3 3/8 [86]	1 1/2 [38]	6 7/8 [175]	3 3/16 [82]	
8	920 [434]	15 1/2 [394]	12 [305]	10 [254]	3 3/8 [86]	1 1/2 [38]	7 7/8 [200]	3 3/16 [82]	
20	2100 [991]	15 1/2 [394]	16 1/4 [406]	10 [254]	2 7/8 [73]	3 5/8 [92]	N/A	3 3/16 [82]	